



Electrical operating instructions

Door control panel TS 954
for Slidingdoor - ELEKTROMATEN®



OPERATING INSTRUCTIONS

	Page
SAFETY DIRECTIONS	E 4
SHARDWARE - OVERVIEW	E 6
FUNCTIONS	E 7
CODING	E 7
LED - DISPLAY	E 8
LED - FUNCTION	E 8
CONNECTION CONTACTOR BOARD 24V	E 9
FIRST INSTALATION	E 10
TERMINAL DESCRIPTION	E 11
WIRING DIAGRAM: MAINS SUPPLY; PUSH BUTTON	E 13
WIRING DIAGRAM: PHOTO-BEAM, SAFETEY EDGES	E 14
INSTALATION DIAGRAM	E 15
DRAWING EXEMPLE FOR SAFETY EDGES	E 16
HELP WITH CORRECTING FAULTS	E 17
TECHNICAL DATA	E 18

SAFETY DIRECTIONS

Basic Directions

This control has been built in accordance with **DIN EN 12453 Industrial, commercial and garage doors and gates - Safety in use of power operated doors - Requirements and DIN EN 12978 Industrial, commercial and garage doors and gates - Safety devices for power operated doors - Requirements and Test methods**; and left the factory in perfect condition from the point of view of safety. To maintain this condition and to ensure safe operation, the user must observe all the directions and warnings contained in these operating instructions.

In principle, only trained electrical craftsmen should work on electrical equipment. They must assess the work which has been assigned to them, identify potential danger sources and take suitable safety precautions.

Reconstruction of or changes to TS 954 are only permissible with the approval of the manufacturer. Original replacement parts and accessories authorised by the manufacturer guarantee safety. Liability ceases to apply if other parts are used.

The operational safety of an TS 954 is only guaranteed if it is used in accordance with the regulations. The limiting values stated in the technical data should not be exceeded under any circumstances (see corresponding sections of the operating instructions).

Safety Regulations

During the installation, initial operation, maintenance and testing of the Control Panel, it is necessary to observe the safety and accident-prevention regulations valid for the specific application.

In particular, you should observe the following regulations (this list is not exhaustive):

European normative

- DIN EN 12445
Safety in use of power operated doors - Test methods
- DIN EN 12453
Safety in use of power operated doors - Requirements
- DIN EN 12978
Industrial, commercial and garage doors and gates -
Safety devices for power operated doors - Requirements and Test methods

Please check normative's bellow.

VDE-regulations

- DIN EN 418
Safety machinery
Emergency stop equipment functional aspects
Principles for design
- DIN EN 60204-1 / VDE 0113-1
Safety of machinery - Electrical equipment of machines - Part 1:
Prescriptions générales
- DIN EN 60335-1 / VDE 0700-1
Safety of household and similar electrical appliances - Part 1:
General requirements



Regulations

- Please ensure that the local regulations relating to the Safety of Operations of Doors are followed

SAFETY DIRECTIONS

Explanation of warnings

These operating instructions contain directions which are important for using the ELEKTROMATEN® appropriately and safely.

The individual directions have the following meaning:



DANGER

This indicates danger to the life and health of the user if the appropriate precautions are not taken.



CAUTION

This warns that the ELEKTROMATEN® or other materials may be damaged if the appropriate precautions are not taken.

General warnings and safety precautions

The following warnings are to be understood as a general guideline for working with the ELEKTROMATEN® in conjunction with other devices. These directions must be observed strictly during installation and operation.



Check that all screw connections are secure before operating the control and adjusting the limit switches.



- Please observe the safety and accident prevention regulations valid for the specific application.
- The ELEKTROMATEN® must be installed with the authorised coverings and protective devices. Care should be taken that any seals are fitted correctly and screw couplings are tightened correctly.
- In the case of ELEKTROMATEN® with a permanent mains connection, an all-pole main switch with appropriate back-up fuse must be provided.
- Check live cables and conductors regularly for insulation faults or breakages. When a fault is detected in the cabling, the defective cabling should be replaced after immediately switching off the mains supply.
- Before starting operation, check whether the permissible mains voltage range of the devices corresponds to the local mains voltage.
- With three – phase motor connection it must have right phase rotation

HARDWARE - OVERVIEW

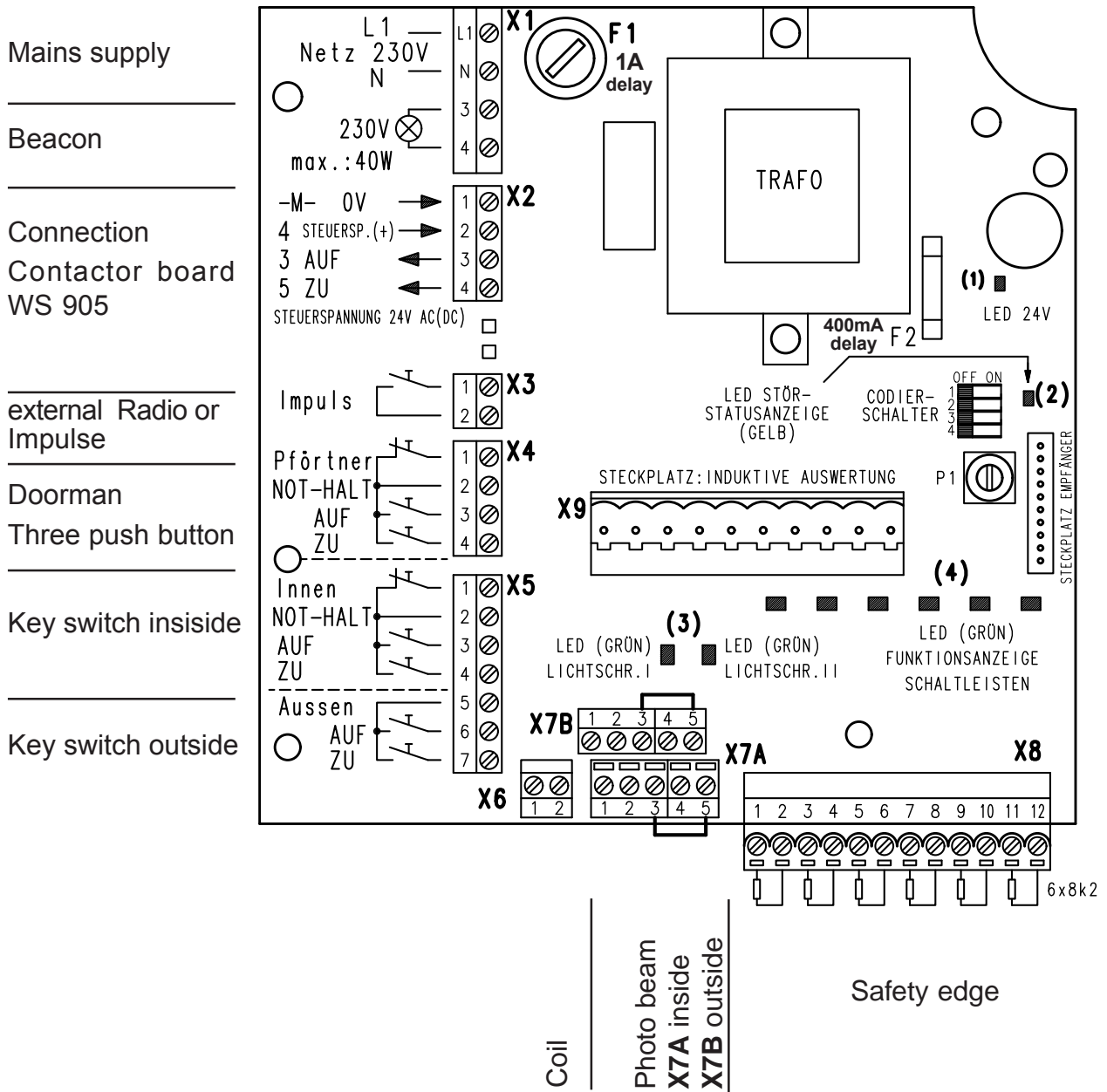

Hardware overview:

Steckplatz Empfänger = plug-in receiver

X9 Steckplatz: Induktive Auswertung = plug-in inductive evaluator card

(1) - (4) Page E 8

FUNCTIONS

Control panel for ELEKTROMATEN® with contactor board.

Control voltage contactor board: 24V AC.

Contactor board with integrated limit switch OPEN / CLOSE mechanical or inductive function

If the control panel TS 954 is in use the door system would be able to be used in AUTOMATIC function, if the required safety devices are connected.

If the safety devices will not be recognised (safety edge/ photo-beam) the control TS 954 switches from Automatic to Hold to Run function.

Evaluation signal of the moving safety edges 1 and 2 can be delivered with a coiled cable or a trailing cable; see Page E 16

The control panel makes an inductive signal transfer to the moving safety edges 1 and 2 possible; see page E 16 fig. 2. This requires an extra plug-in card (ASO) (X9).

The control panel has automatic closing function available, this can be switched OFF. If adjusted the door closes automatically from final OPEN position. The timer can be adjusted by using POTI / P1 from 10 up to 180 seconds. An extra function running time monitoring for about 150 seconds is always available and must not be adjusted or disconnected. The drive unit will be switched OFF to avoid longer working than 150 second.

Plug-in card

- Radio receiver 2-channel - Impulse or separate OPEN / CLOSE-command.
- ASO card inductive Signal transfer (X9) for travelling safety edges.

CODING

- | | | |
|----|-----|-----------------------------------------------------------------------------------------------------------------------------------------------------------------------------------------|
| 1. | OFF | Radio control: 1 channel impulse |
| | ON | Radio control: Channel 1 = OPEN, Channel 2 = CLOSE |
| 2. | OFF | Photo –beam only in CLOSE direction active. Closing starts with a 5 seconds fore-warning. |
| | ON | After a OPEN or CLOSE command the will not travel if the photo-beam is interrupted. Photo beam is only in CLOSING direction active. The fore-warning appears in both travel directions. |
| 3. | OFF | Automatic closing deactivated. |
| | ON | Automatic closing activated. Timer adjustment with Poti P1 from 10 up to 180 seconds. Before closing the door a 5 second forewarning appears. |
| 4. | OFF | Service without inductive signal transfer. |
| | ON | Inductive Signal transfer (ASO) for travelling safety edges 1 and 2
ASO plug-in card X9 require |

LED - DISPLAY

LED`s

- | | |
|------------------------------------|-----------------------------------------------------------------------------------------------------------------------------------------------------------------------------------------------------------------------------------------------------------------------------------------|
| (1) 24V
Green | Display Hardware
LED ON: 24V Voltage available
LED OFF: 24V not available, check Fuse F2 and 230V |
| (2) Fail - Status
Yellow | Diagnostic - display
Blinking status see „LED DIAGNOSTIC“ |
| (3) Photo beam
Green | Photo beam 1 (X7A); Photo beam 2 (X7B)
LED ON: Photo beam ready for service
LED OFF: Failure photo beam or F2 (to approve this set bypass to terminal 3 - 5) |
| (4) Safety edge
Green | Safety edge 1 up to 6
LED ON: Safety edge ready for service
LED blinking: Safety edge activated
LED OFF: Cable break or F2 defect

If inductive transfer (safety edge 1 and 2)
LED ON: Safety edge ready for service
LED OFF: Safety edge contacted or cable break |

LED - FUNCTION

LED Yellow	Blinking	Fail- Status displayed Software
LED ON: static ON		NO Failure
LED ON: 1 x flash OFF		Continuous command at the station e.g. (pushbutton)
LED ON: 2 x flashes OFF		Emergency – Stop activated
LED OFF: 1 x flash ON		Safety edge 2 x contacted (door reversed)
LED OFF: 2 x flashes ON		Time out running time exceed (> 150 seconds)
LED OFF: 3 x flashes ON		Output fault (command OPEN / CLOSE check wiring at terminal X2 / 3-5). Switch mains supply OFF/ON to make reset. Check wiring contactor board
LED OFF: 4 x flashes ON		Testing for inductive transfer (plug-in card X9) negative If appears again, re-send ASO card to be approved
LED: continuous flashing		Control panel in Hold to Run mode

CONNECTION CONTACTOR BOARD 24V



DANGER! To the life and health thru electric shock
Before mounting the mains supply must be switched OFF

Before tacking the control TS 954 in service, the contactor board WS 905 must be connected and approved.

Check as follows:

1. Switch ON mains supply and check function of contactor board with touching built-in pushbutton **S11 OPEN / S13 CLOSE**. If the contactor will not be activated check control voltage. Check also connection of the limit switches.
2. **Check motor rotation!**
Push button **S11 OPEN** causes a working of the contactor K1 (OPEN). The door must OPEN. If the door travels in closing direction the motor rotation must be changed.
3. Limit switches **S11 OPEN / S13 CLOSE** adjustment.



Important note!

The contactor board and control panel TS 954 control voltage must be checked that a corresponding control voltage of 24V AC is available for both controls.

Control panel TS 954 with contactor board WS 905 / 24V:

Control panel TS 954 requires the external contactor board WS 905, 2 contactors 24V. This is an essential part of the ELEKTROMATEN® drive unit.

Manuals:

51171169 with integrated limit switch, with / without magnetic brake,
with / without electro mechanical brake

or

51171174 for external limit switch, with / without magnetic brake, with / without electro
mechanical brake

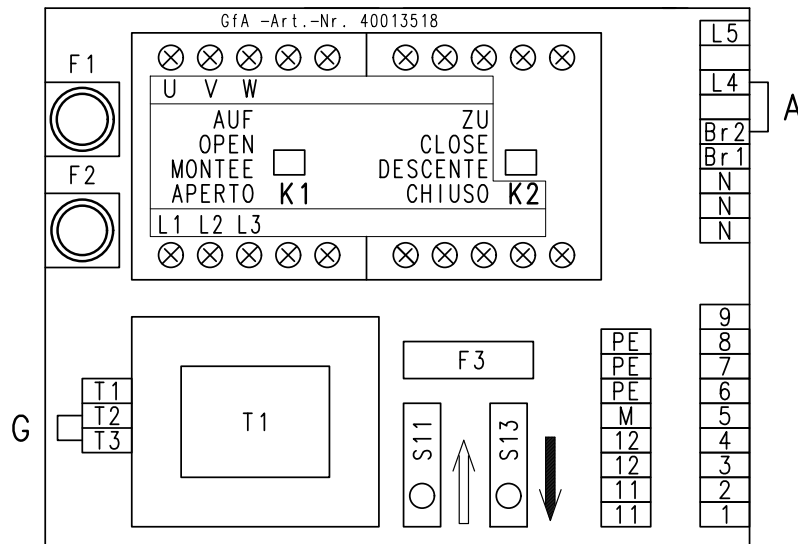

FIRST INSTALATION

If the contactor board WS 905 was checked properly the TS 954 can be taken in use.

We recommending as follows:

1. Make connection between WS 905 and TS 954 (Terminals: **X1** und **X2**).
Attention, the 7-core connection cable has 2 voltages available (230V AC und 24V AC)
2. Push button (Key switches) close to the door must be connected at Terminal: **X4** or **X5**. Power on. The door should travel in both directions in SELFHOLD.
3. Otherwise all bridges (bypasses) and resistors must be checked regarding the instruction. **Attention** this is only for first installation required
4. Motor rotation shall be checked
5. Photo beam can be connected and checked (Terminal: **X7A** / **X7B**) **if available**
5. Safety edges can be connected (Terminal: **X8**) **if available and the end of line resistors 8K2 must be removed**. Observe LED's displayed.



Attention!

The control is supplied with bridges and end of line resistors. If these terminals would be used the bridges for photo beam and end of line resistors must be removed.

OPTIONAL:

6. USE of plug-in card. Observe manual.
7. If timer function required, adjust Potentiometer (**P1**) **and** coding switch 3 set **ON**.

TERMINAL DESCRIPTION

X1 = L1 - N 230V supply for control panel 954.
3 - 4 Beacon 230V max.: 40W will be switched ON always.

X2 = Connection TS 954 with contactor board to:

	Control panel	TS 954	contactor board WS 905
1	0V	(M)	(UB)
2	Control panel 24V	(4)	(2)
3	OPEN	(3)	(3)
4	CLOSE	(5)	(5)

Connection external devices

X3 = 1 - 2 Impulse contact **OPEN / STOP / CLOSE** e.g. Also valid for radio control to be connected.
Impulse function only possible if safety devices connected and recognised by the control panel

X4 = 1 - 4 **Three push button OPEN / STOP / CLOSE outside the door area**
These terminals are to be used with external pushbuttons
Commands OPEN / CLOSE working only if the safety devices are recognised. All input terminals of the safety devices which are not in use, (Safety edge/Photo beam) must be bypassed with an 8,2K resistor. The OPEN command has principally higher importance. Will OPEN be actuated while closing, the door reverses with a short delay.
A CLOSE command while opening will stop the door.
A Emergency STOP command stops all functions.
A continuous OPEN command stops timer count down.

X5 = 1 - 4 **Key switch OPEN / CLOSE and Emergency stop inside close to the door**
This terminal is to be used for all devices they are in the area of visibility of the door. The door can travel in both directions without safety devices; however the functions are HOLD TO RUN (DEAD MAN-Principle). With proper working safety devices the door travels in SELFHOLD OPEN and CLOSE direction.
The OPEN command has principally higher importance. Will OPEN be actuated while closing, the door reverses with a short delay.
A CLOSE command while opening will stop the door.
A Emergency STOP command stops all functions.

5 - 7 **Key switch OPEN / CLOSE ; outside close to the door**
This function is identical with key switch inside X5: 1-4 however without emergency stop button.

TERMINAL DESCRIPTION

X6 = 1 - 2 Coil connection can only be used for inductive signal transfer. Plug-in card must be set to X9.

Terminal X8: 1-2, 3-4 must not be used. (No Resistor)
Set coding switch to ON

X7A/B = 1 - 5 Connection of two thru-safety photo beam or reflex photo beam possible. This is to secure the closing direction of the door. If the photo beam would be triggered while door is closing, the door will stop and reverses to final position OPEN. The reversing impulse works only if safety edges 2, 3 and 4 are in proper use.

If the photo beam would be actuated a closing of the door in SELFHOLD is interrupted.

When the control with the door works in emergency mode only (DEAD MAN mode, the safety devices should be checked and the function changes back to SELFHOLD if the fitted safety devices are properly working.

Connection of safety edges to be used with integrated evaluator.

Safety edges can be connected by a 12-pole plug-in connection X8.

Terminal 1-2 and 3-4 for 2 of with the door travelling safety edges (ahead and behind), these inputs must not be used if inductive signal transfer card available. (No Resistor). For all of these safety edges an end of line resistor 8K2 required, if X9 is not used.

X8 = 1 - 2 **Safety edge 1**
Main closing edge at the door frame to secure close direction. Will this safety edge be actuated while the door closes, the drive unit reverses the door to the final OPEN position, however this is only if the other safety edges 3 and/4 fitted to the building (pillar) are not actuated at that time.

3 - 4 **Safety edge 2**
Secondary safety edge at the door frame to secure OPEN direction. Will this safety edge be actuated while the door opens, the drive unit reverses the door only for a duration of 3 seconds in CLOSE direction, however only if the travelling safety edge 1 and safety edge 5 and 6 fitted to the building (pillar) are not actuated at that time.
In this time photo beam is out of order.

5 - 6 **Safety edge 3**
7 - 8 **Safety edge 4**
Fitted to the building to secure the OPEN direction.
Will these safety edges 3 and / or 4 be actuated, the drive unit reverses the door for a duration of 3 seconds in CLOSE direction, however only if non of the safety edged 5 / 6 and 1 has been actuated at that time.

9 - 10 **Safety edge 5**
11 - 12 **Safety edge 6**
Fitted to the building to secure the CLOSE direction.
Will these safety edges 5 and / or 6 be actuated, the drive unit reverses the door for a duration of 3 seconds in OPEN direction, however only if non of the safety edged 3 / 4 and 2 has been actuated at that time

WIRING DIAGRAM: MAINS SUPPLY; PUSH BUTTON

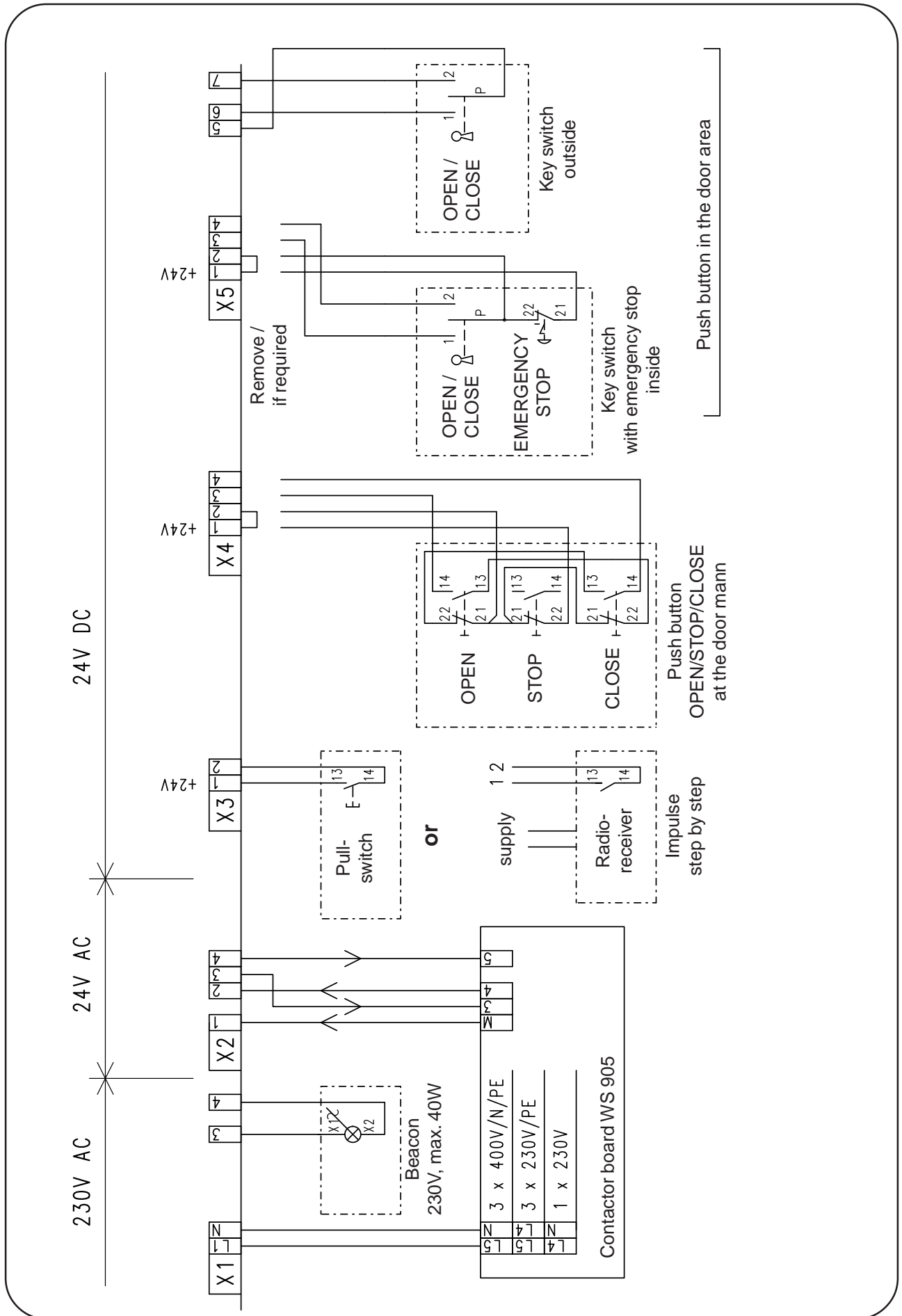

WIRING DIAGRAM: PHOTO-BEAM, SAFETY EDGES

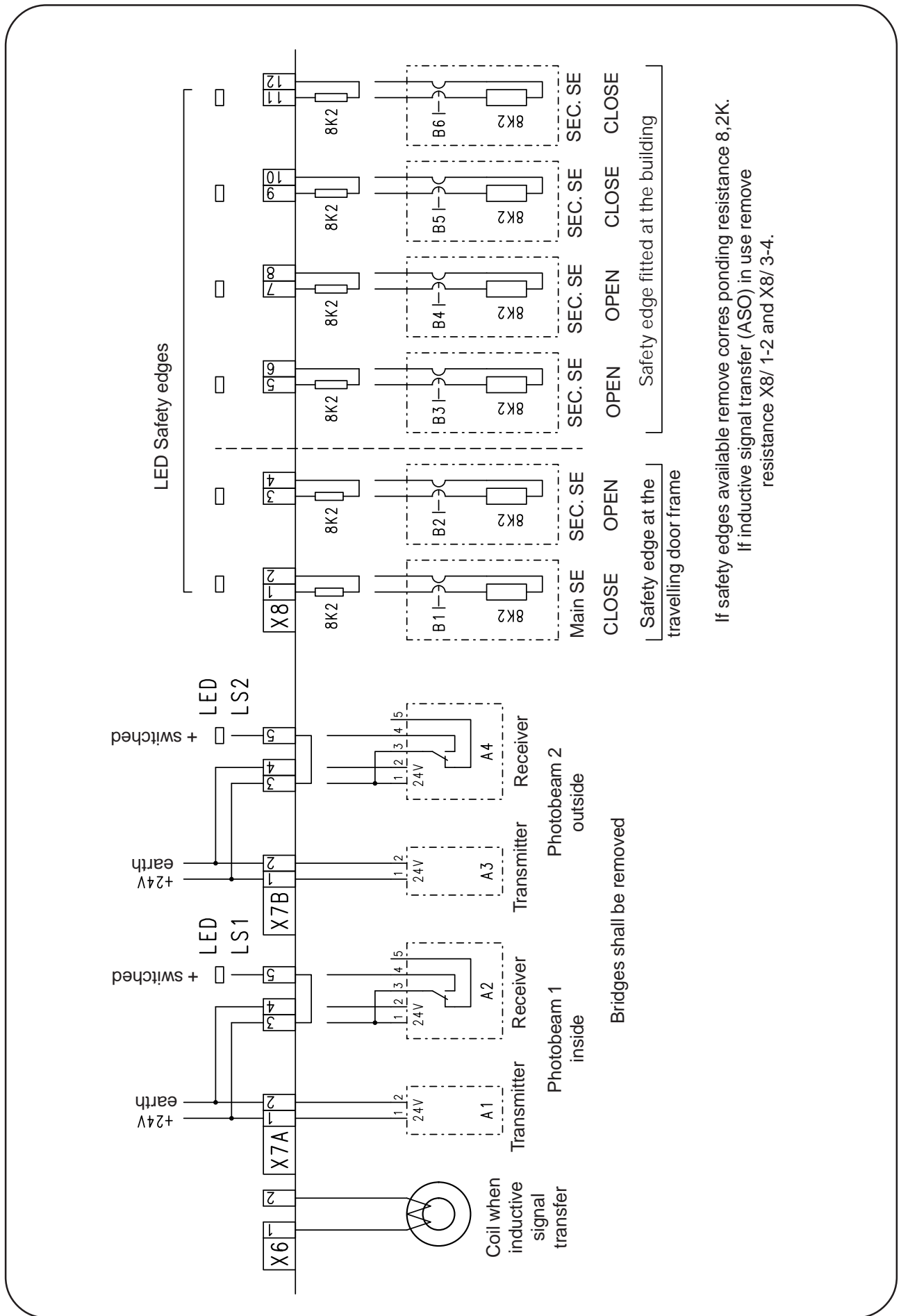

INSTALATION DIAGRAM

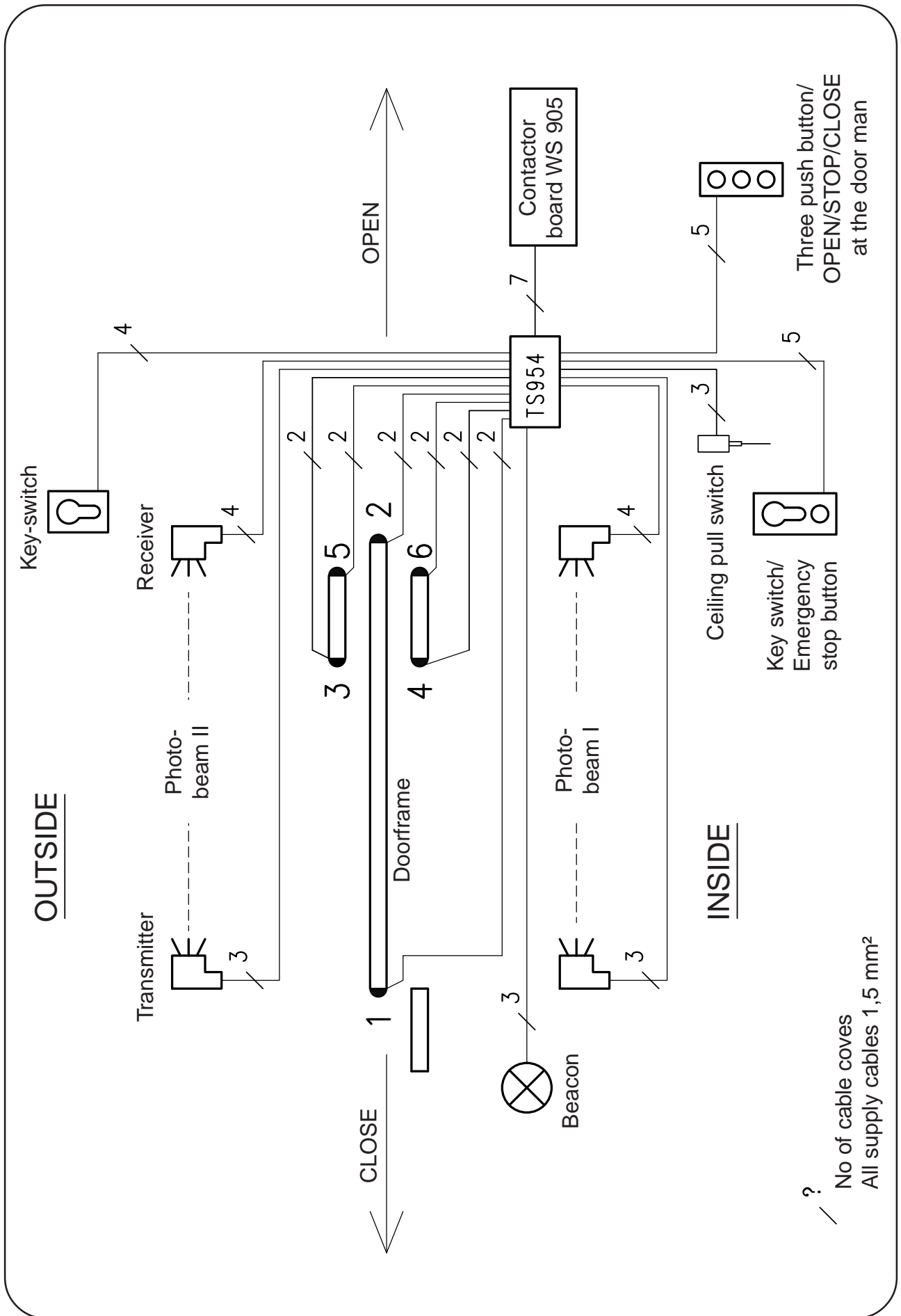

DRAWING EXEMPLE FOR SAFETY EDGES

FIG.: 1

SIGNAL TRANSFER - COILED CABLE

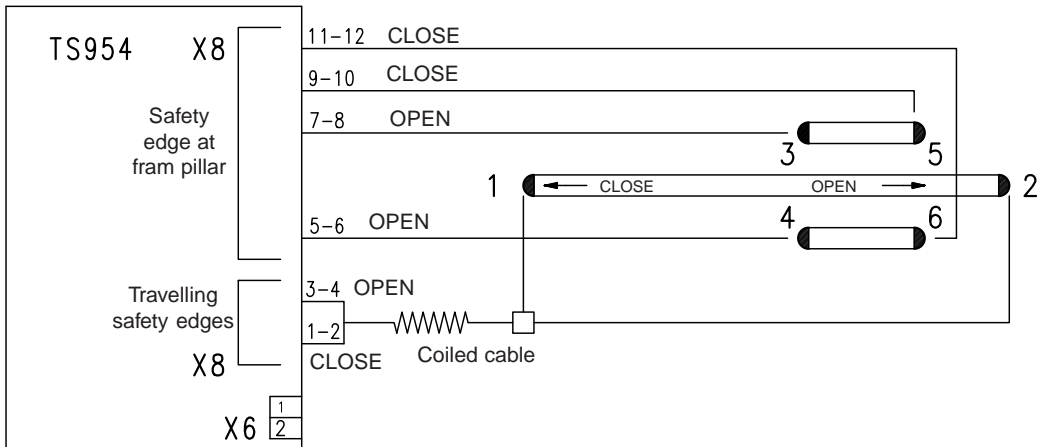

FIG.: 2

INDUCTIVE SIGNAL TRANSFER (ASO) INTERNAL EVALUATION SELF CODING SWITCH 4 = ON

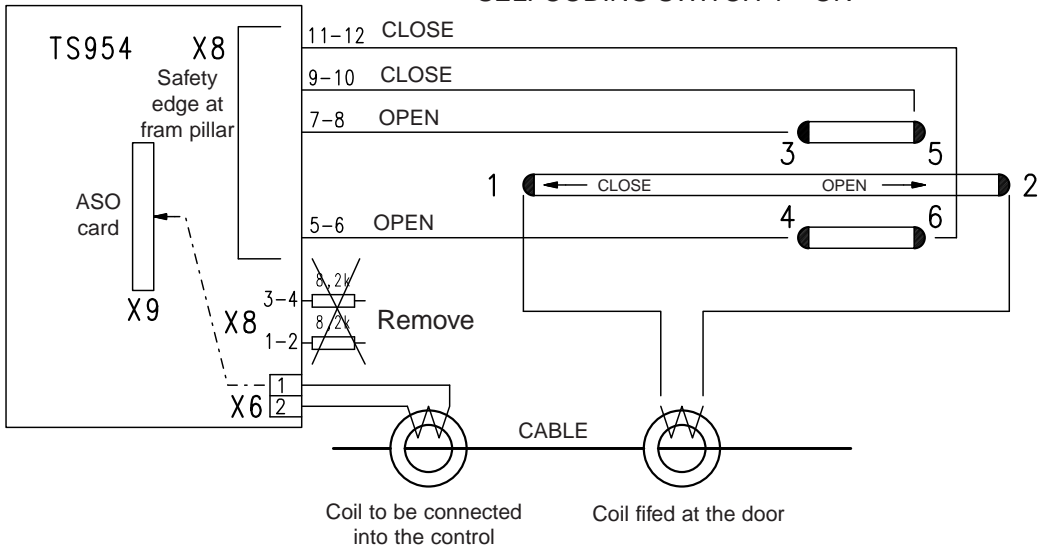
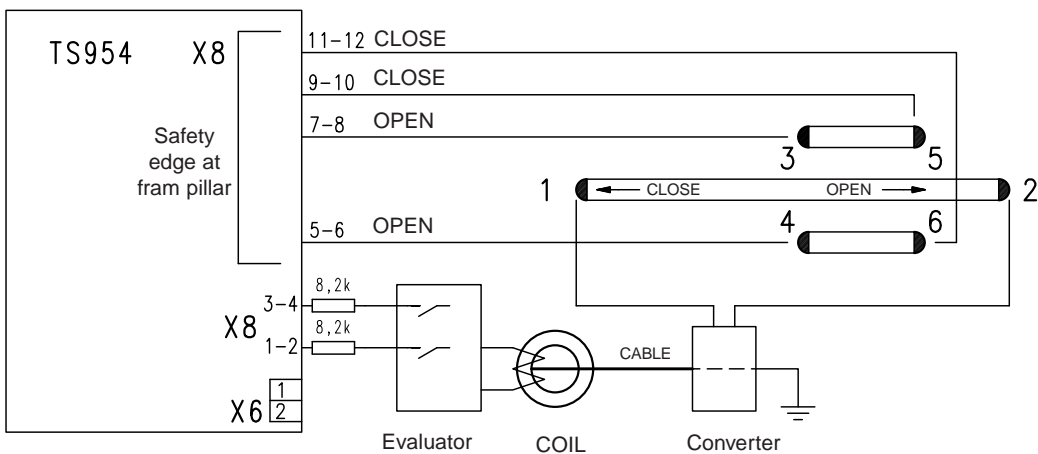

FIG.: 3

INDUCTIVE SIGNAL TRANSFER EXTERNAL EVALUATION



All safety edges require an 8,2K resistance

DIAGNOSTIC AND REPAIR

Failure - drive unit out of order	
Eventually causes	How to repair
Voltage 230V not available All LED's OUT	Check contactor board by pushing the built in push button OPEN/ Close for function. Check fuse F1/F (see manual WS 905). Measure voltage 230V at terminal X1/ L1-N and check cable connection WS 905 - TS 954.
Supply of 24V not available	Check contactor board for function.. Measure voltage 24V AC at terminal X2/1-2 and check cable connection WS 905 - TS 954.
Supply of 24V not available Only yellow LED (2) is glows	Measure voltage 24V DC at terminal X7/1-2 Check fuse F2 .
If the safety circuit is interrupted yellow LED ON and 2 x flashes OFF	Make wiring X4/ 1-2 or X5/ 1-2 respectively connect STOP button.
Failure - NO SELFHOLD OPEN / CLOSE	
Eventually causes	How to repair
Hold to RUN (DEAD MAN) CLOSE Photo beam out of order - green LED (3) OFF	Make wiring X7 / 3-5. For testing make short period bypass 3-5. Just to see LED switches ON
Hold to RUN (DEAD MAN) OPEN/ CLOSE Safety edge system is defect – the green LED (4) of defect safety edge is OFF	Repair defect safety edge and for testing, dismantle the cabling and wire at the place an end of line resistor 8,2k Ohm
Failure - Beacon	
Eventually causes	How to repair
Short circuit	Check fuse F1
Bulb defect	Replace bulb

TECHNICAL DATA

Housing ABS Plastic (Dimensions)	W x H x D ; 225 x 180 x 75mm
Mounting	horizontal
Voltage supply	230V 50Hz supplied from WS 905
Control voltage contactor board	24V AC
Supply voltage TS 954	24V DC, max. 110mA
Beacon / Traffic light	230V max. 40W
Photo beam	24V Thru or reflexive photo beam
Control panel Current consumption	6,5VA (consume without drive unit)
Input	24V DC all inputs must be connected without potential
Safety edges	electrical (NO contact) with resistore 8K2
Signal transfer	Spiral cable 2 / 4 cors or inductive (ASO)
Automatic closing	10-180 second free adjustable
Gateway evacuation period	5 second fixed, not changeable
Running time monitoring	150 seconds fixed, not changeable
Plug-in Radio receiver	434 MHz self coding 2-channels Typ EKX2SM
Temperature	Working: -10...+50°C Storage: -20.. .+70°C
Humidity	Up to 95% not condensing
Vibration	Vibration free mounting e. g. on a flat built wall
Protection class	Housing IP55
Weight	1,6 kg