



Installation instructions

Safety brake

FG 220-60 part no. 10003911.00001

FG 220-65 part no. 10003913.00001

FG 360-80 part no. 10003912.00001

-en-

Status: i / 03.2020



GfA ELEKTROMATEN GmbH & Co. KG
Wiesenstraße 81 • 40549 Düsseldorf

🌐 www.gfa-elektromaten.de

✉ info@gfa-elektromaten.de

List of Contents

1 Safety directions.....	4
2 Technical data.....	5
3 Dimensions	5
4 Principle of function	6
5 Mechanical installation	7
6 Electrical installation	8
7 Function: Event of operation	10
7.1 Repair – Replacement.....	11
8 Inspection	13
9 Declaration of conformity	14

Symbole



Danger! – This indicates danger to the life and health of the user if the appropriate pre-cautions are not taken!



Danger! – This indicates danger to the life and health of the user through electrical shock, if the appropriate pre-cautions are not taken!



Important note! – Contents important information!



1 Safety directions

Specified normal use

This safety brake (anti-fallback device) is designed and tested to be used for rolling shutter, rolling grilles etc. that must be prevented from falling back. To ensure safe operation the user must observe all the directions. GfA accepts no liability for damages as a result of incorrect usage. Technical changes are not permitted without prior consent of the manufacturer; otherwise the given declaration of incorporation will expire.

Safety instructions

In principle, only qualified and trained mechanical craftsmen shall install this safety brake and put into operation and only qualified and trained electrical craftsmen should work on electrical equipment. They must assess the work which has been assigned to them, identify potential danger sources and take suitable safety precautions. Before starting assembly, disconnect the cables from the electricity supply and check that they are dead. Make sure the drive unit can not be switched on during installation. While working on the safety brake, it is necessary to observe any related Health and Safety rules and regulations applicable at the time.

Safety brake

If the drive mechanism is worn out, or the transmission chain is broken or other causes, in consequence the door starts to fall down, the safety brake engages automatically. The falling load will be stopped in the actual position and protected against falling down. The use of the safety brake is depending on maximum rotation speed (rpm) and rotating direction, it is maintenance –free and self-controlling.

When the safety brake has operated (catching the door) it must be inspected and eventually repaired or replaced, only by qualified and trained craftsmen or engineers.

2 Technical data

Size		FG 220-60	FG 220-65	FG 360-80
Part number		10003911.00001	10003913.00001	10003912.00001
Maximum output torque	Nm	2200	2200	3600
Admissible output speed open /close	rpm	27 / 15	27 / 15	27 / 15
Hollow shaft diameter D	mm	60	65	80
Keyway width B	mm	18	18	22
Keyway height H	mm	64,4	69,4	85,4
Locking torque	Nm	6691	6691	10260
Admissible bearing load F_{max}	N	10000	15000	15000
Safety brake-(approval no.)		IFT 240 438 19	IFT 240 438 19	IFT 240 438 19
Permissible temperature	°C	-20 / +60	-20 / +60	-20 / +60
Protection class	IP	65	65	65

3 Dimensions

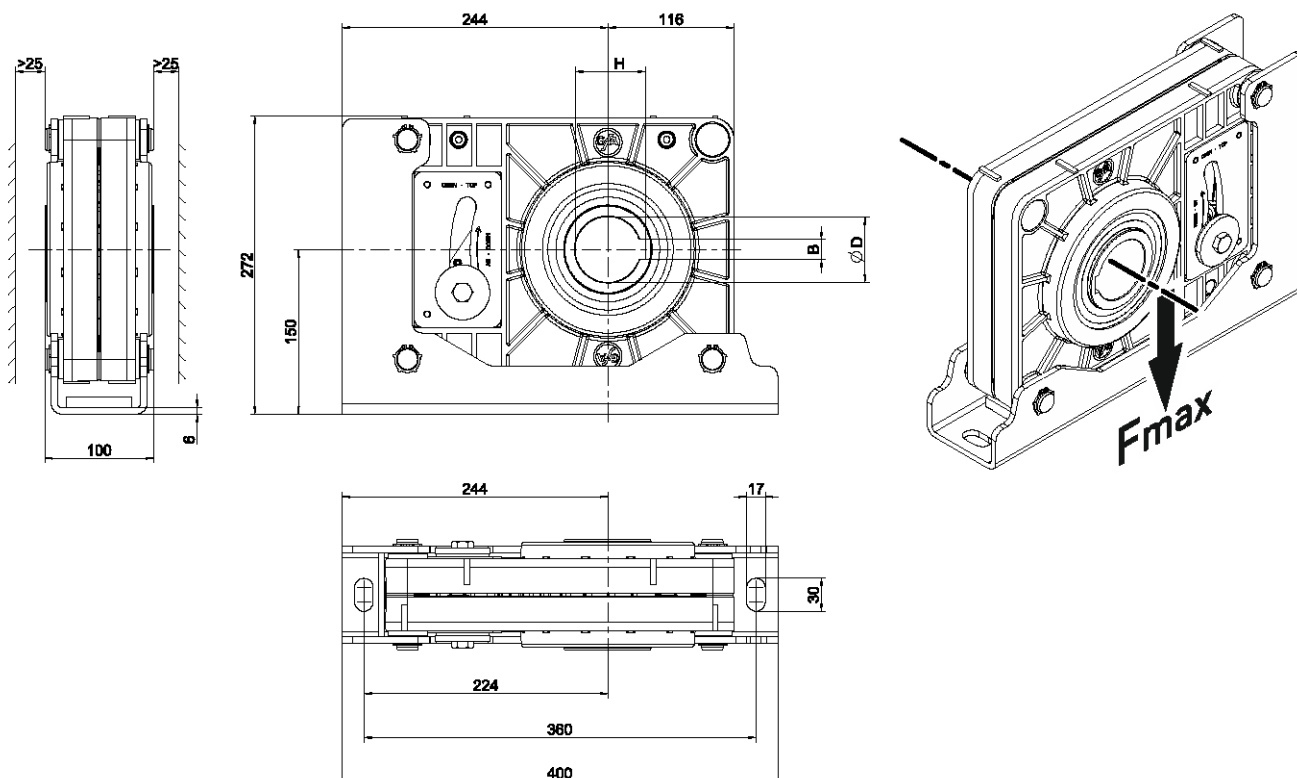

On request, we supply following data, if part number available:

- Drawings (dxf, dwg, pdf)
- 3d-Data file

4 Principle of function

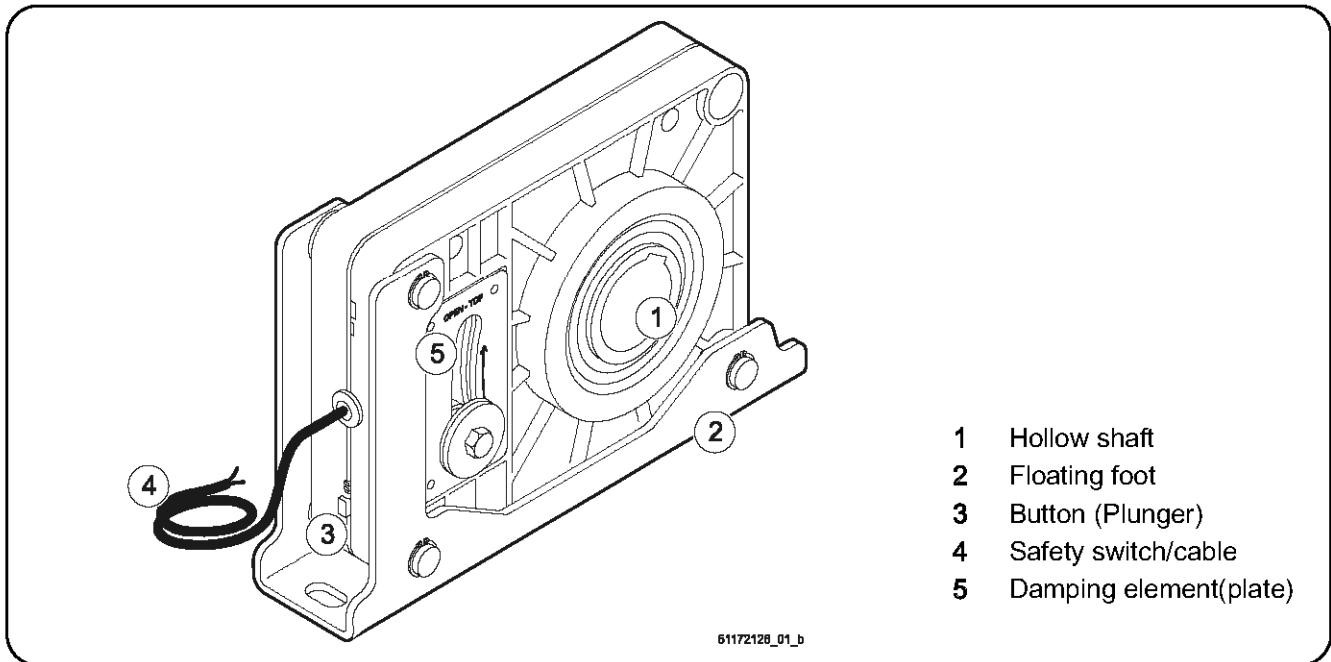

By worn of the gear or chain break the door will fall down unintended. The door shaft speed exceeds up to the activating speed of the safety brake. After actuation „fall energy“ will be absorbed and the door Stops. Should the safety brake be activated, the safety switch will be activated to interrupt the control current of the drive unit. Electrical operation is no longer possible.

The actuation will be optically indicated by the outstanding red button.

Service position:

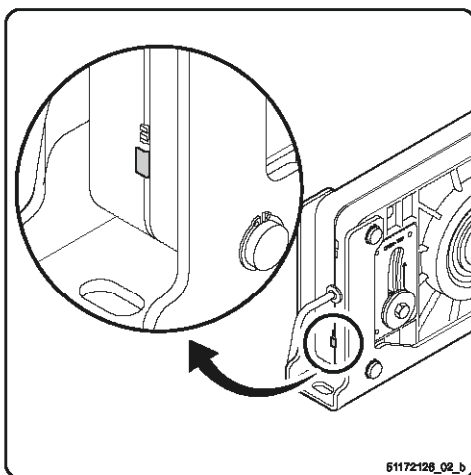

Operating position:

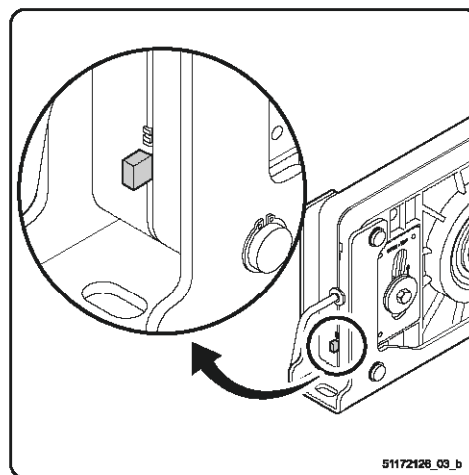

When the safety brake has operated (catching the door) it must be inspected and eventually repaired or replaced, only by qualified and trained craftsmen or engineers.

5 Mechanical installation



Attention!

- The locking torque moment must not exceed the admissible loads on mechanical components such as e.g. fixing bolts, shafts, keys etc.

- Hollow shaft must be greased before installing.
- Safety brake shall be moved without force over the door shaft, fixed and tightened.

Admissible fitting position:

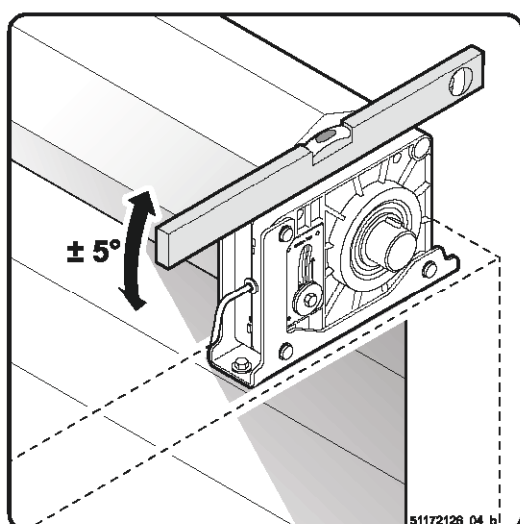

Attention!

- When the safety brake has operated, the damping elements (plates) must be inspected and if necessary replaced, only by qualified and trained craftsmen.
- Therefore a minimum of 25 mm space is required on both sides.

6 Electrical installation



Warning – Danger to life from electrical shock!

- Disconnect the cables (mains OFF) and check that the supply is off
- Observe the applicable regulations and standards
- Ensure proper electrical connection
- Use suitable tools



Warning - Danger due to uncontrolled movement!

The connection cable of the safety brake must be protected against cross-faults. If a cross-fault occurs, the safety switch does not interrupt the control current. A movement of the door due to a movement command cannot then be ruled out.

- Ensure that the installed connection cable is protected.

Cross-fault: A cross-fault is a short circuit between two wires inside a cable.

Should the safety brake be activated, the safety switch will be activated to interrupt the control current of the drive unit (see – 4 *Principle of function* –). Electrical operation is no longer possible.

Carrying out the electrical installation (drive unit: GfA-ELEKTROMATEN)

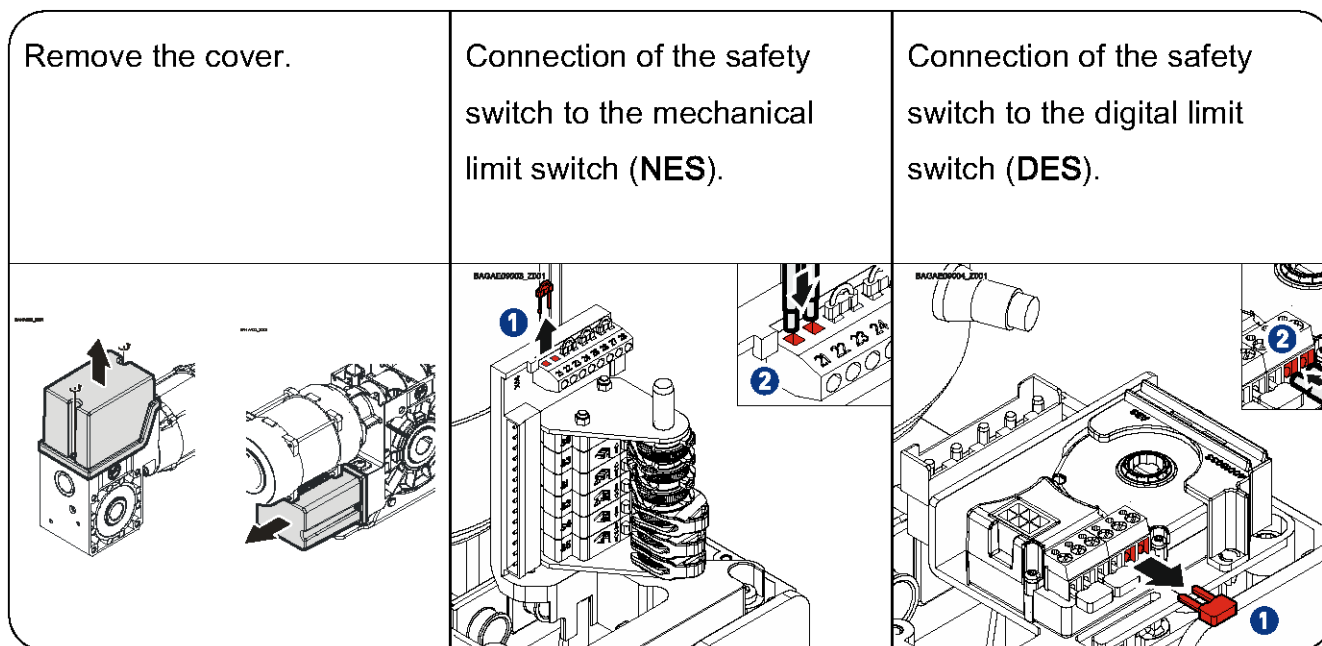

Carrying out the electrical installation (drive unit: alternative manufacturer)

Instructions on how to connect the safety switch can be found in the documents provided by the manufacturer of the drive unit or control system.

Completing the electrical installation

Install cable entries and/or cable glands.

7 Function: Event of operation

When the safety brake has operated (catching the door) it must be inspected and eventually repaired or replaced only by qualified and trained craftsmen or engineers.

In the stopping position a safety switch will be contacted continuously and interrupts the electrical safety circuit of the drive unit. The door becomes out of order. The actuation will be optically indicated by the outstanding red button.



Danger!

- Disconnect the drive unit from electrical power and protect against accidental operation.
- Protect the door against falling.
- Repair the cause of failure (drive mechanism, brake, chain)

Service position:

Operating position:

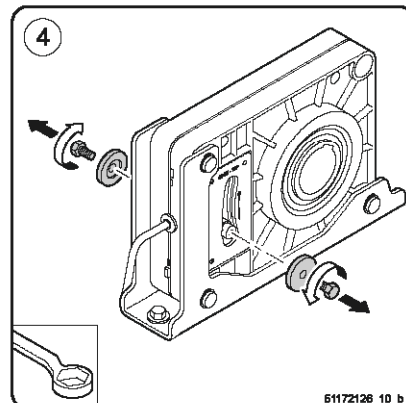
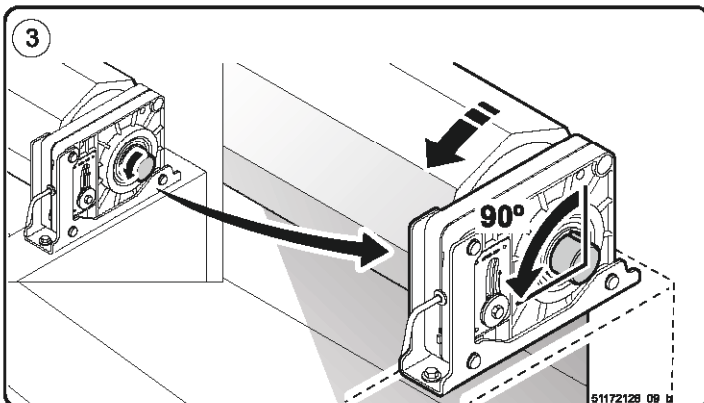
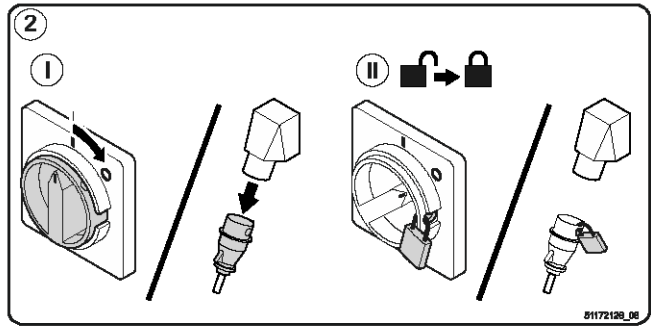
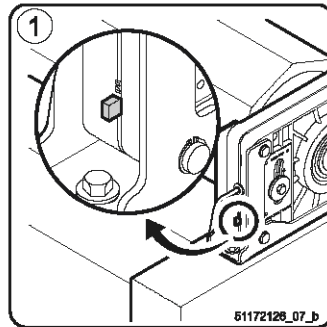
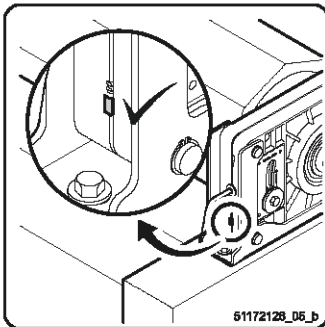

7.1 Repair – Replacement

Actuated – Situation - A

- Red button comes out
- Damping elements undamaged
- Safety brake OK
- Next ⑬....⑯

Actuated – Situation - B

- Red button comes out
- Damping elements damaged
- Replace the damping elements
- Next ⑧...⑯

Actuated – Situation - C

- Red button comes out
- Damping elements overstrained
- Replace the safety brake because of damage

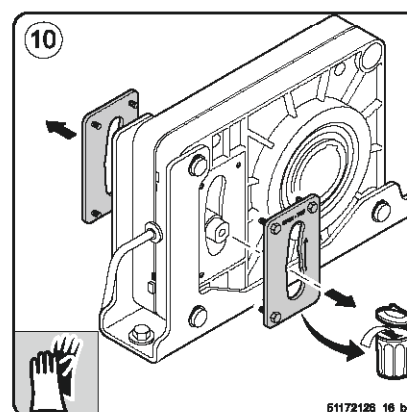
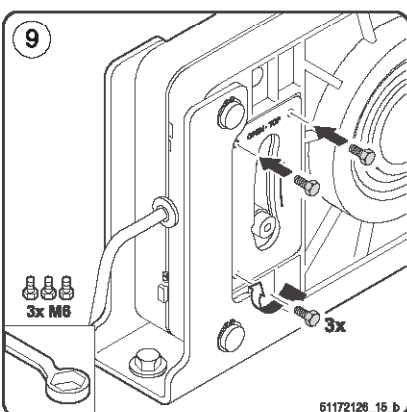
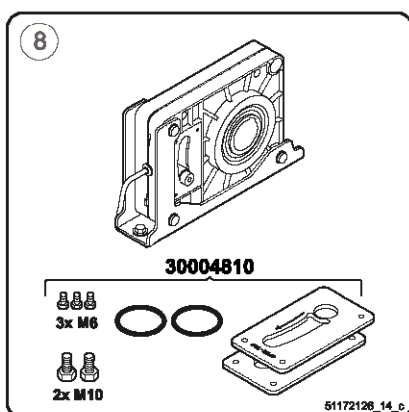
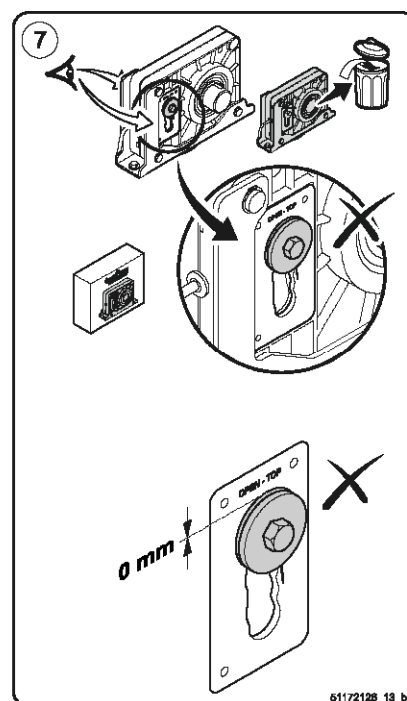
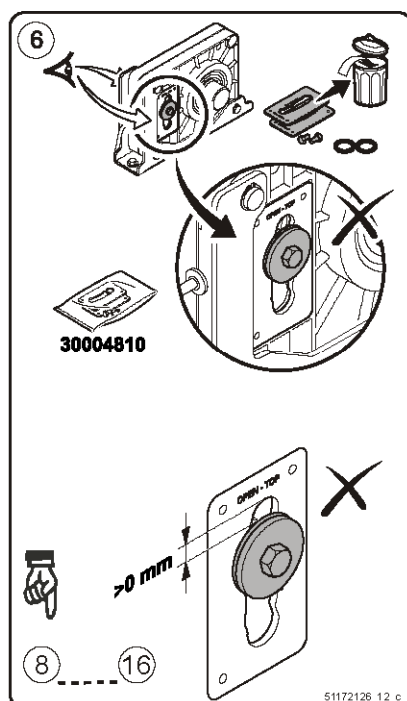
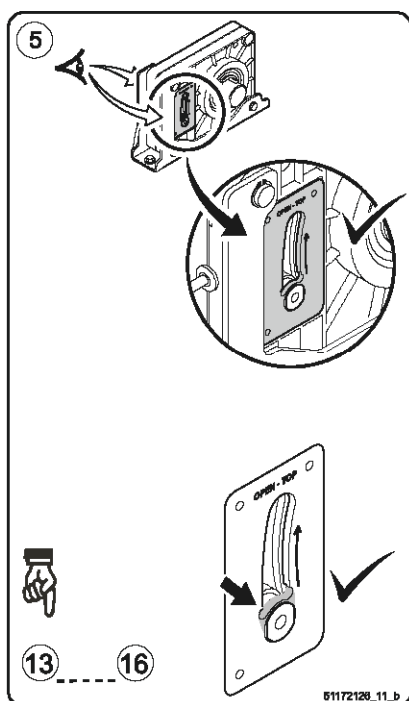

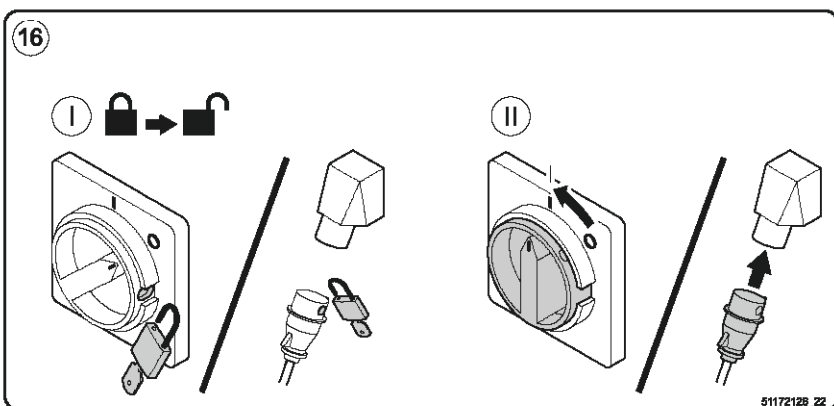
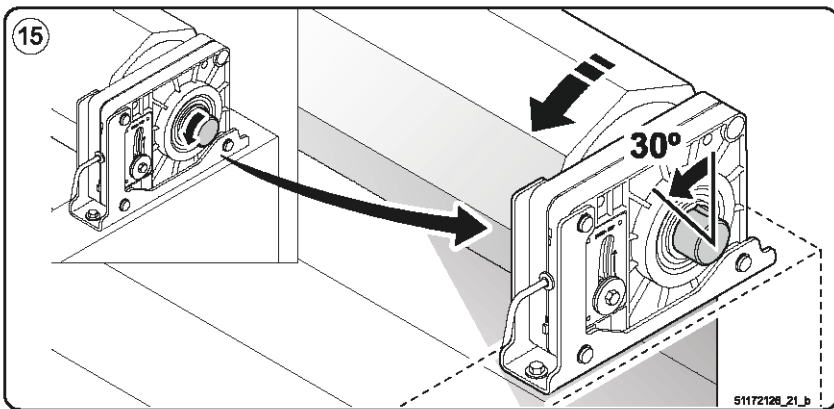
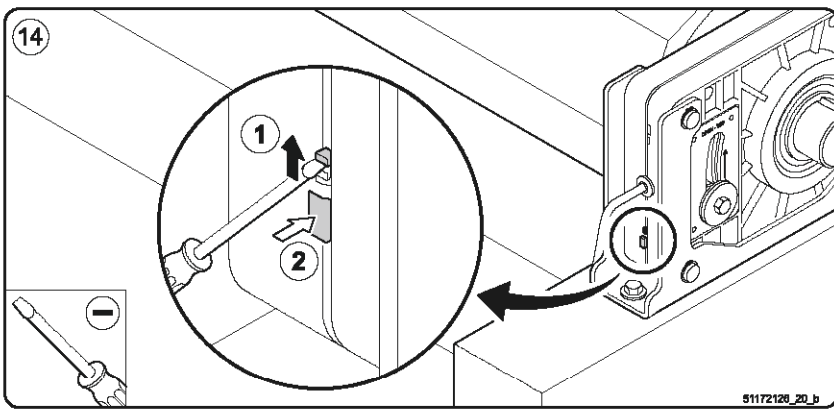
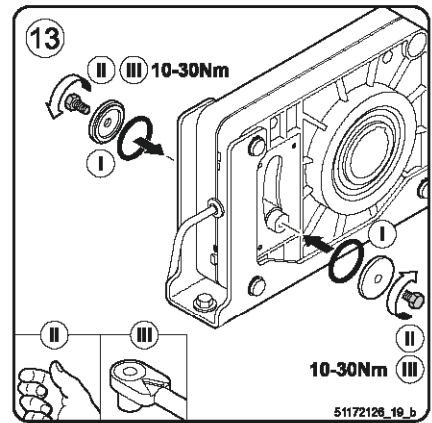
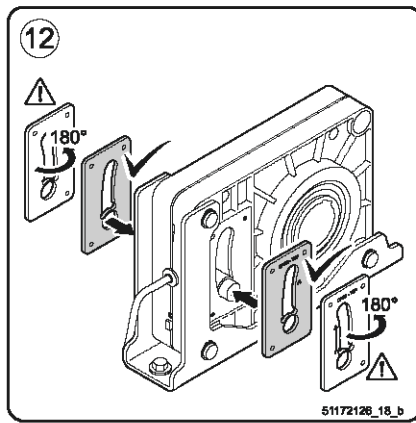
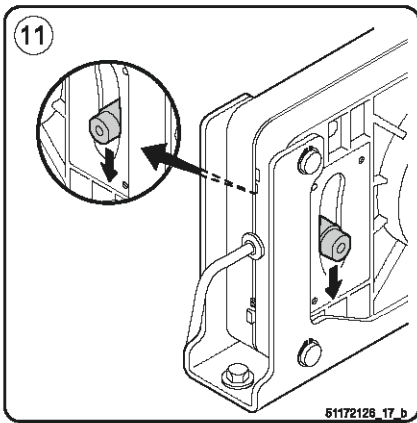

8 Inspection



Attention!

- All regulations relating maintenance, inspection, application and also valid directions and normative must be observed.

This safety brake is maintenance-free

Mounting position

- **! Advice** (OBEN = TOP respectively AB = DOWN marking)

Electrical switch

- Proper condition of cable and connection must be inspected

Mechanical parts

- Proper condition and tightness of fixing elements and bolts must be inspected.

Spare parts



Attention!

- Only original replacement parts and accessories must be used.

We do not accept liability or providing any guarantee against damage caused by using non original replacement parts and accessories.

Disposal

- The disposal of packing material and replaced safety brake unit must follow valid regulations and laws.



9 Declaration of conformity

Declaration of conformity

within the meaning of Machinery Directive 2006/42/EC

within the meaning of RoHS Directive 2011/65/EU



GfA ELEKTROMATEN GmbH & Co. KG
Wiesenstraße 81 · 40549 Düsseldorf
Germany

We, the
GfA ELEKTROMATEN GmbH & Co. KG
hereby declare that the following products are
conform with the above Guideline and are only
intended for installation in door equipment.

Safety brake
FG 220-60, FG 220-65, FG 360-80

Part no.:
1-3911.00001, 1-3913.00001, 1-3912.00001

Authorised representative to compile the
technical documents is the undersigned.

Düsseldorf, 10.08.2018

Stephan Kleine
CEO

Signature

Standards applied:

EN 12604:2017

Industrial, commercial and garage doors and
gates - Mechanical aspects - Requirements and
test methods

EN 12605:2000

Industrial, commercial and garage doors and
gates - Mechanical aspects - Test methods

EN 60204-1:2006

Safety of machinery - Electrical equipment of
machines - Part 1: General requirements

