



Installation Instructions

ELEKTROMAT

ST 9.24-25,00

Model: 10002917 00002

-en-

Status: 06.03.2020



GfA ELEKTROMATEN GmbH & Co. KG
Wiesenstraße 81
D-40549 Düsseldorf
🌐 www.gfa-elektromaten.de
✉ info@gfa-elektromaten.de

Table of contents

1	General safety information	4
2	Technical Data	5
3	Mechanical installation	6
4	Electrical installation	10
5	Motor connection	11
6	Limit switch connection	11
7	Completing commissioning / inspection.....	12
8	Declaration of incorporation / Declaration of conformity.....	14

Symbols



Warning - Potential injury or danger to life!



Warning - Danger to life from electric current!



Note - Important information!



Requirement - Required action!

Schematic representations are based on product examples. Deviations from delivered products are possible.



1 General safety information

Specified normal use

The drive unit is intended for horizontally operating sliding doors.

The safe operation is only guaranteed with specified normal use. The drive unit is to be protected from rain, moisture and aggressive ambient conditions. No liability for damage caused by other applications or non-observance of the information in the manual.

Modifications are only permitted with the agreement of the manufacturer. Otherwise the Manufacturer's Declaration shall be rendered null and void.

Safety information

Installation and initial operation tasks are to be performed by skilled personnel only.

Only trained electrical craftsmen are permitted to work on electrical equipment. They must assess the tasks assigned to them, recognise potential danger zones and be able to take appropriate safety measures.

Installation work is only to be carried out with the supply off.

Observe the applicable regulations and standards.

Coverings and protective devices

Do not operate unless corresponding coverings and protective devices are installed.

Ensure that gaskets are fitted correctly and that cable glands are correctly tightened.

Spare parts

Only use original spare parts.

2 Technical Data

Type	SG 50R	
Output torque	90	Nm
Output speed	24	rpm
Output shaft / hollow shaft	25,00	mm
Maximum output speed open / close for frequency inverter operation	42 / 42	rpm
Maximum door weight	9000	N
Supply voltage	3N~ 400	V
Operating current	1,20	A
Operating frequency	50	Hz
Power factor $\cos \varphi$	0,87	
Maximum movement per hour	12	h ⁻¹
Class of protection	IP 54	
Limit switch range (maximum revolutions of output shaft / hollow shaft)	20	
Braking torque of magnetic brake	65	Nm
Braking voltage	103	V DC
Rectifier type	B1 230/103	
Temperature range	-10 / +40 (+60)	°C

1) When using a temperature range of +40°...+60°C use half of maximum movements per hour.



Temperature Extension!

If the magnetic brake will be continuously supplied the drive can be fitted into areas down to a -20°C ambient temperature.

3 Mechanical installation

Prerequisites

The permissible loads on walls, fastenings, mountings and transmission elements must not be exceeded, even for maximum holding torques or locking torques (► refer to technical data).

Connection elements

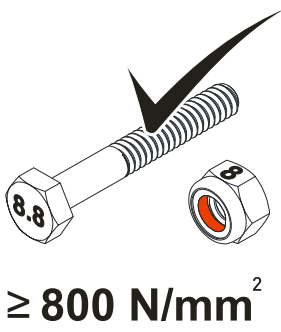
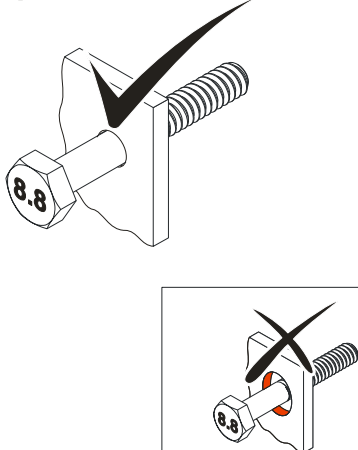
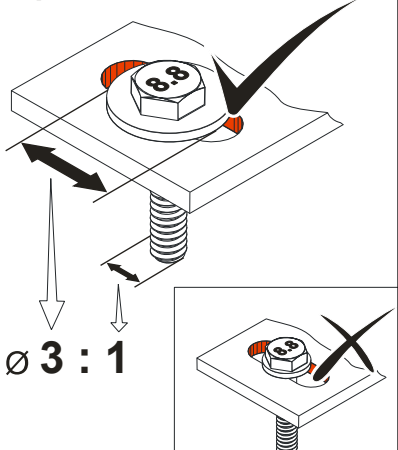
<ul style="list-style-type: none"> ► Self-locking connection elements with a minimum strength of 800 N/mm² (8.8) must be used. 	<ul style="list-style-type: none"> ► Utilize the hole diameter to the full. 	<ul style="list-style-type: none"> ► Use adequately dimensioned washers for elongated holes.
<p>BAGAB00001_Z002</p>  <p>≥ 800 N/mm²</p>	<p>BAGAB00002_Z002</p> 	<p>BAGAB00003_Z002</p>  <p>Ø 3 : 1</p>

Permissible mounting positions

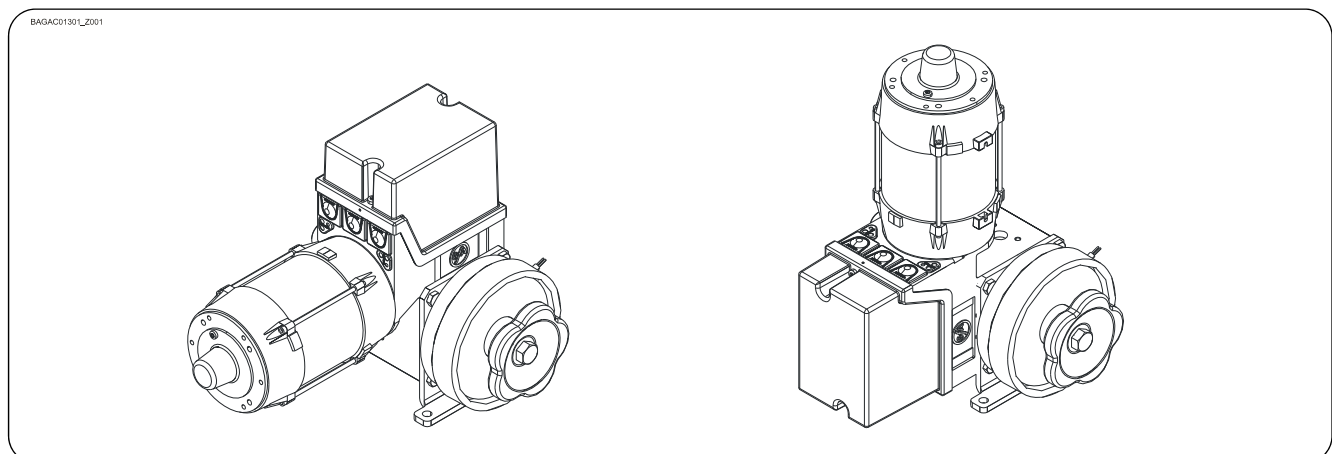

Mounting

Four holes are provided for mounting.

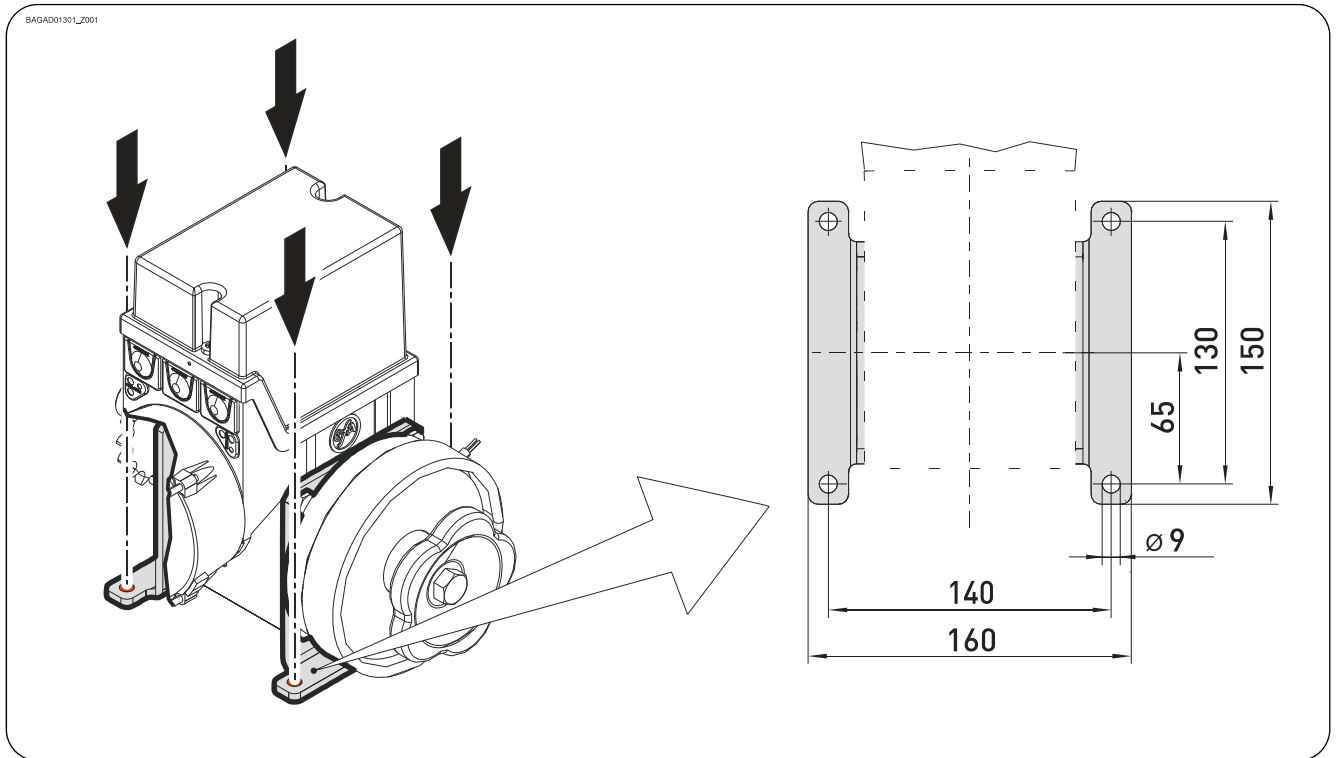

Installation

The descriptions below apply to general door specifications. The specifications of the door manufacturer must also be observed during installation.



Warning - Potential injury or danger to life!

- During installation, be sure to use a lifting device that has a sufficient load-carrying capacity.
- Ensure that there is sufficient space around the handwheel for safe operation of the friction clutch.

- ▶ The output-shaft must not be shortened.

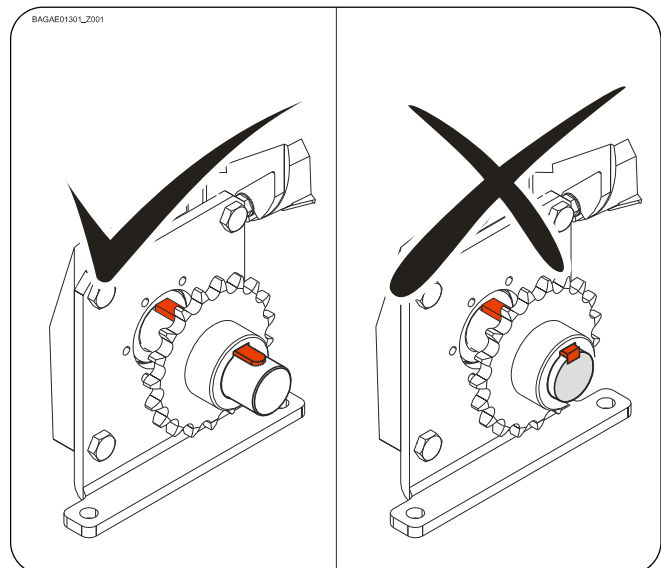

- ▶ Tighten all connection elements (M8) to 25 Nm. Install all other connection elements according to the specifications of the door manufacturer.

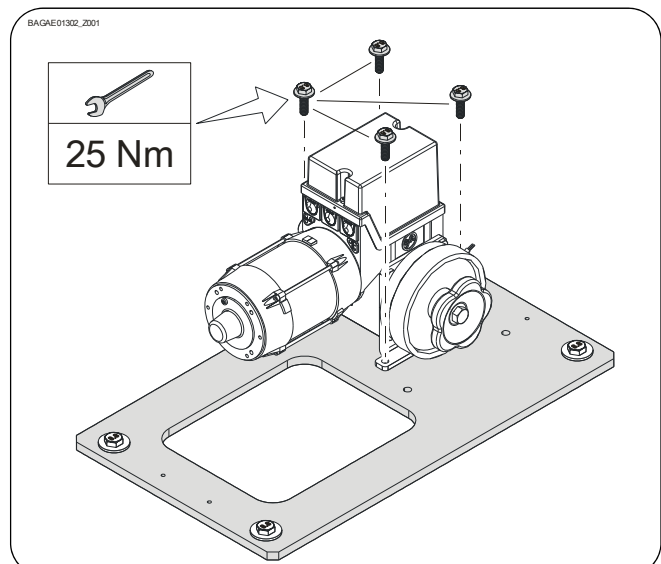



Warning - Potential injury or danger to life!

- Disconnect the electric supply to set the friction clutch.

The friction clutch provides overload protection. It is tightened finger-tight at the factory. Turning to the right (handwheel or screw) increases the transferable torque. Turning to the left decouples the drive unit from the door (does not apply to version with floor release).

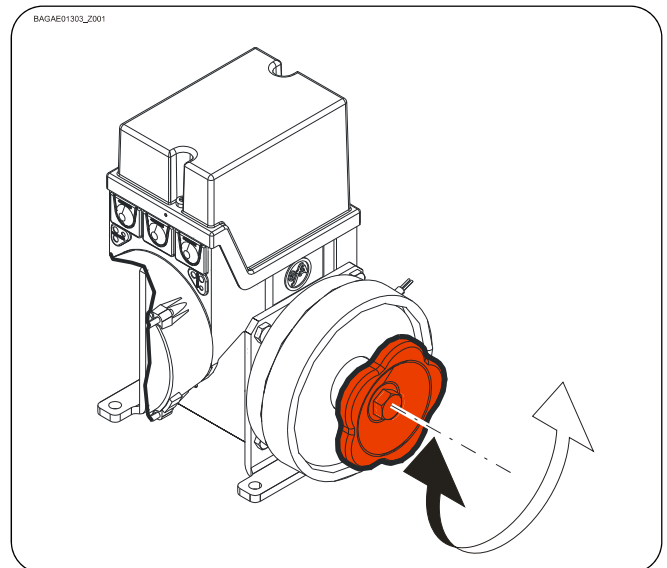

4 Electrical installation



Warning - Danger to life from electric current!

- Switch the mains OFF and check that the cables are de-energised
- Observe the applicable regulations and standards
- Make a proper electrical connection
- Use suitable tools

Performing electrical installation

Remove the cover.

Connect the motor cables and brake cables.

BH4A15_2001

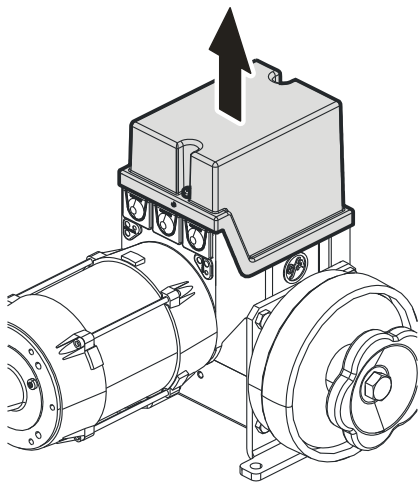

BH4A08_2001

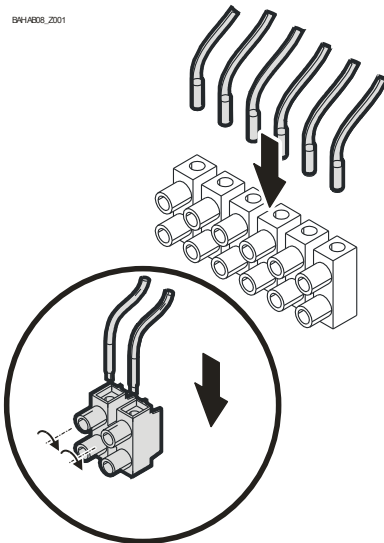

Completing the electrical installation

Mount the cable entries and/or cable glands.

5 Motor connection

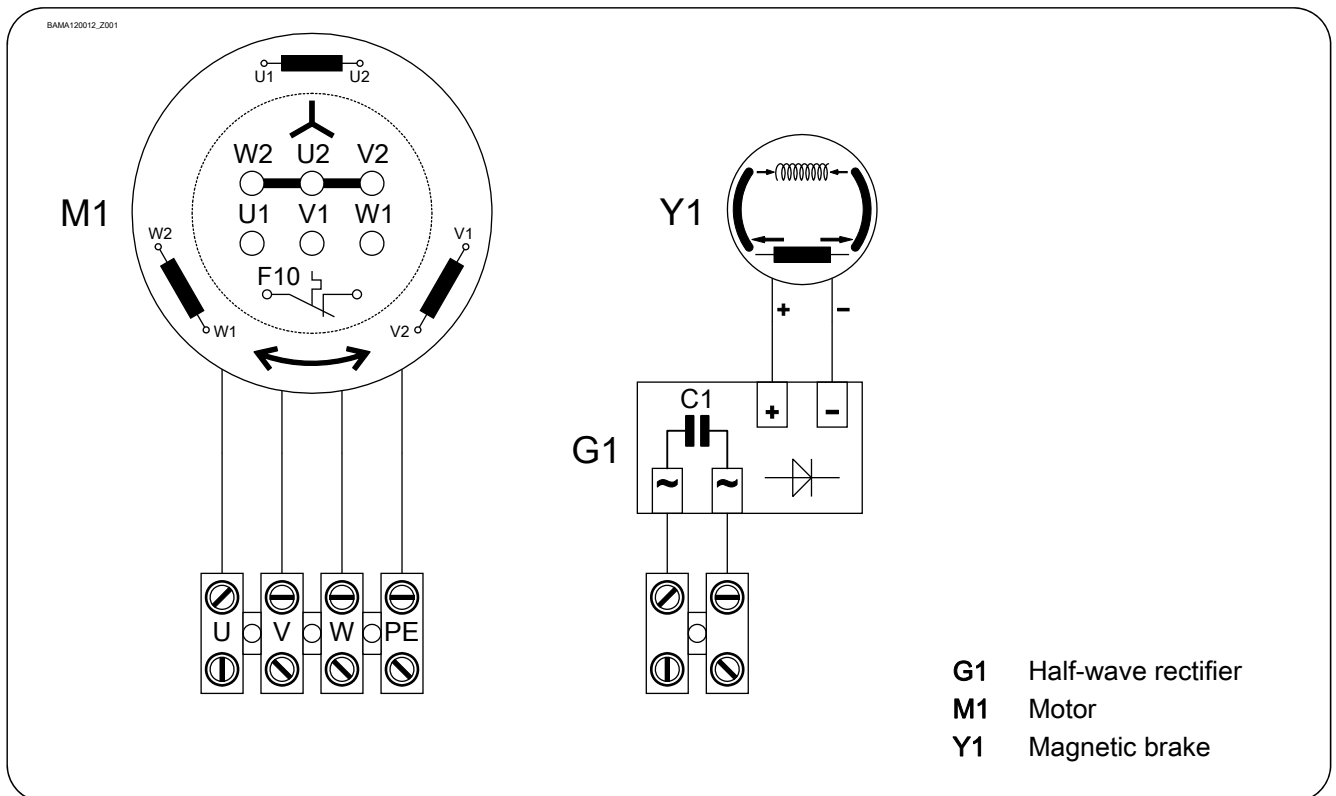

6 Limit switch connection

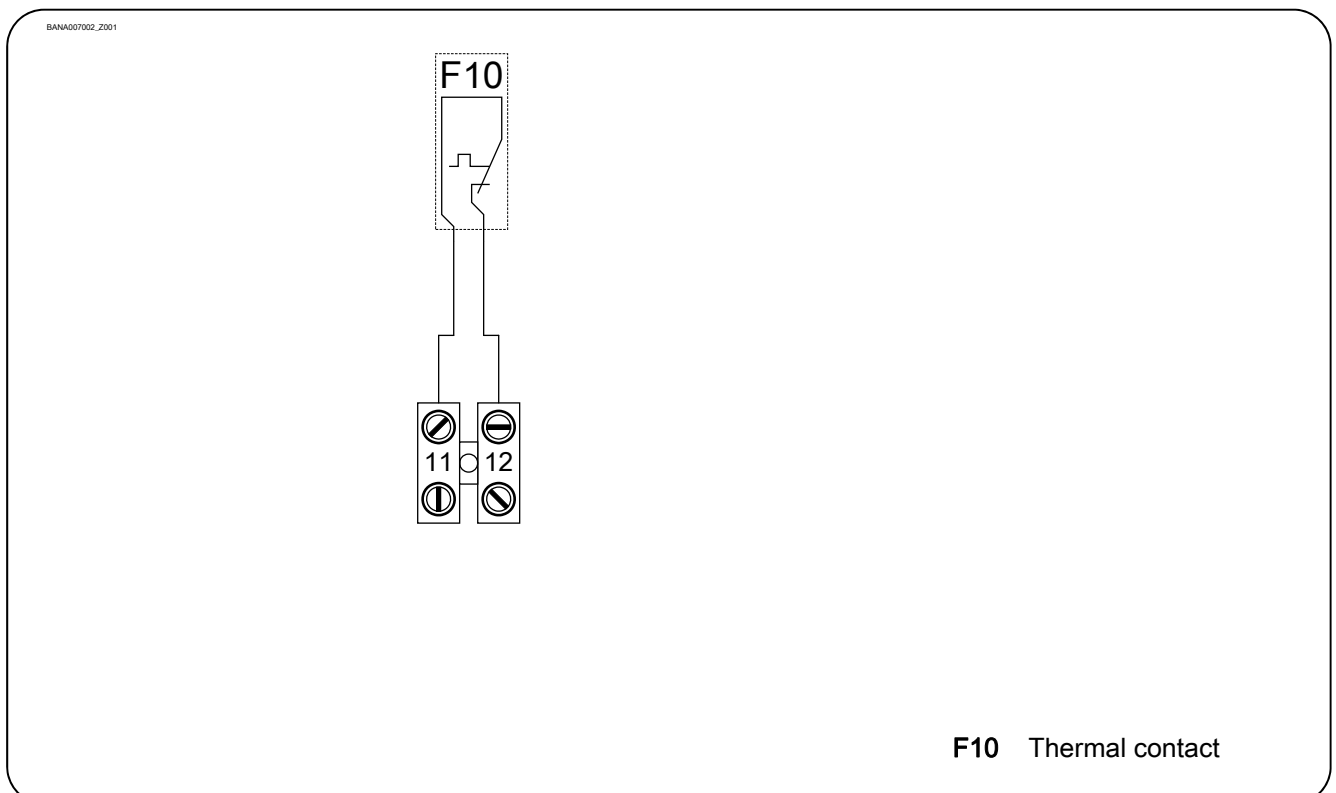



7 Completing commissioning / inspection

Check the following components and then install all covers.

Gearbox

Check the drive unit for loss of oil (a few drops can be neglected). Protect the output-shaft permanently against corrosion.

Mounting

Check that all connection elements (consoles, torque mounts, screws, locking rings, etc.) are secure and in proper condition.

Electrical wiring

Check the connection cables and cabling for damage or crushing. Check that the screw connections and plug connections are fitted properly with a good electric contact.

Brake



Warning - Potential injury or danger to life!

- Carry out a brake test. Overrun depends on the door and its equipment. The specifications of the door manufacturer must be observed.

In an environment that can affect the coefficient of friction of the brake pad (atmosphere with oil, solvents, detergents, etc.), class of protection IP65i must be adopted.



Note!

- Engage a qualified engineer to check the drive unit annually
- Apply shorter inspection intervals for doors that are operated frequently
- Observe the applicable regulations and standards

Declaration of incorporation

within the meaning of Machinery Directive 2006/42/EC
for partly completed machinery, Appendix II Part B



GfA ELEKTROMATEN GmbH & Co. KG
Wiesenstraße 81 · 40549 Düsseldorf
Germany

Declaration of conformity

within the meaning of EMC Directive 2014/30/EU
within the meaning of RoHS Directive 2011/65/EU

We,
GfA ELEKTROMATEN GmbH & Co. KG
declare under our sole responsibility that the
following product complies with the above
directives and is only intended for installation in a
door system.

Drive unit
ST 9.24-25,00
Part no.: 10002917 00002

We undertake to transmit in response to a
reasoned request by the appropriate regulatory
authorities the special documents on the partly
completed machinery.

This product must only be put into operation
when it has been determined that the complete
machine/system in which it has been installed
complies with the provisions of the above-
mentioned directives.

Authorised representative to compile the
technical documents is the undersigned.

Düsseldorf, 10.08.2018

Stephan Kleine
CEO

Signature

The following requirements from Appendix I of
the Machinery Directive 2006/42/EC are met:
1.1.2, 1.1.3, 1.1.5, 1.2.2, 1.2.3, 1.2.6, 1.3.2,
1.3.3, 1.3.9, 1.5.1, 1.5.2, 1.5.4, 1.5.6, 1.5.7,
1.5.8, 1.5.9, 1.5.10, 1.5.11, 1.5.13, 1.6.1, 1.6.2,
1.6.4, 1.7.2, 1.7.3, 1.7.4.3.

Standards applied:
EN 12453:2001
Industrial, commercial and garage doors and
gates - Safety in use of power operated doors -
Requirements

EN 12604:2017
Industrial, commercial and garage doors and
gates - Mechanical aspects - Requirements

EN 60335-1:2012
Household and similar electrical appliances -
Safety - Part 1: General requirements

EN 61000-6-2:2005
Electromagnetic compatibility (EMC) Part 6-2
Generic standards – Immunity standard for
industrial environments

EN 61000-6-3:2007
Electromagnetic compatibility (EMC) Part 6-3
Generic standards – Emission standard for
residential, commercial and light-industrial
environments

