

# FDS 100

## Fire Shutter Door Drives



### Introduction

This instruction book is suitable for use with the following FDS 100 fire shutter door drive units.

DLA150W

**Please read the following instructions before proceeding with the installation of your drive unit.**

## **Safety at Work**

It is the responsibility of the owner, installer and user to ensure that the installation of the equipment and the way in which it is operated and maintained complies with the requirements of the Health & Safety at Work Act in the United Kingdom and other applicable legislation, regulations and codes of practice in the UK or elsewhere.

Only qualified personnel should install this equipment, after first reading and understanding the information in this publication. The installation instructions should be adhered to.

## **Inspection**

Immediately after unpacking the equipment, please inspect as follows:

Check the rating plate corresponds to the order specification.

Inspect the equipment to determine whether it has been damaged in transit.

Look for loose components and damage to any part of the motor, covers, mounting brackets or other components.

## **Product Enquiries**

If at any time you have a difficulty or a question regarding the equipment, please contact the supplier at the address on the back cover of this manual.

The following information will be required.

- a) Equipment type.
- b) Age of equipment.
- c) The nature of the problem - for instance, the location and extent of damage, the point which is unclear or the circumstances under which a malfunction occurred.

## **Documentation**

Every effort has been made by supplier to ensure that this document accurately and completely represents the equipment at the time of going to press. Information with respect to installation is necessarily generalised, and the supplier accepts no liability for contingencies over which he has no control in respect of the selection, installation and/or operation of equipment.

In line with our policy of continuous improvement, the contents of this document are subject to change without prior notice.

## Mounting the drive

The FDS 100 range of drives are supplied with a mounting plate which is designed to be used in conjunction with a special bearing housing. The mounting plate and bearing housing will already be mounted onto the shutter cheek plate.

Fit the safety brake to roller. Ensure the direction arrow on the brake is pointing in the "shutter" down direction. Install the roller with the safety brake sitting on its bracket and with the sprocket end located in the bearing housing.

Lift and swing the bearing retaining pin across the top of the bearing and ensure it is clipped home securely.

**Note this is a safety critical item.**

Fit the drive unit onto the mounting plate with the three M10 bolts provided and tighten. Fit the roller chain from the drive to the barrel. Ensure the mounting plate clamp bolts are only finger tight and then tension the chain. Once adjusted fully tighten the mounting plate bolts.

Rotate the drive using the hand chain and check throughout a complete revolution of the barrel, that the chain tightness remains within the recommended figures.

**Note: Do not remove the drive sprocket without first referring to the supplier.**

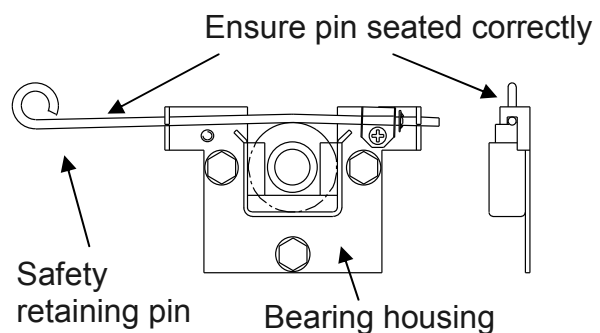
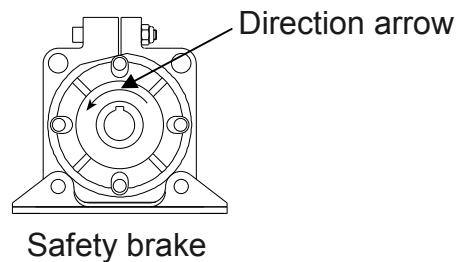
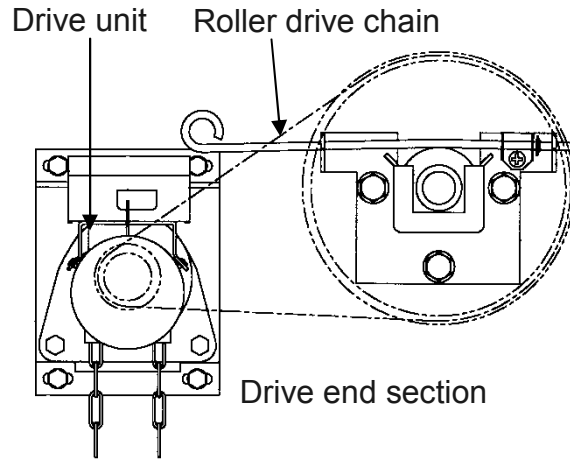

---

## Release mechanisms

---

Each drive unit has fitted to it a 'Fire' release mechanism. Please check your drive has the correct one for the installation and then refer to the relevant instruction:

### 1. Level 3 fire - Alarm operated, automatic reset.

During installation only electrical connections are required.

### 2. Level 2 fire - Alarm operated, manually reset.

This unit is fitted with a bowden cable assembly that requires fixing to a suitable point adjacent to the drive. When an alarm signal is received the solenoid activates the release mechanism. Once the alarm signal has been removed, the handle on the bowden cable should simply be pulled to reset the solenoid mechanism.

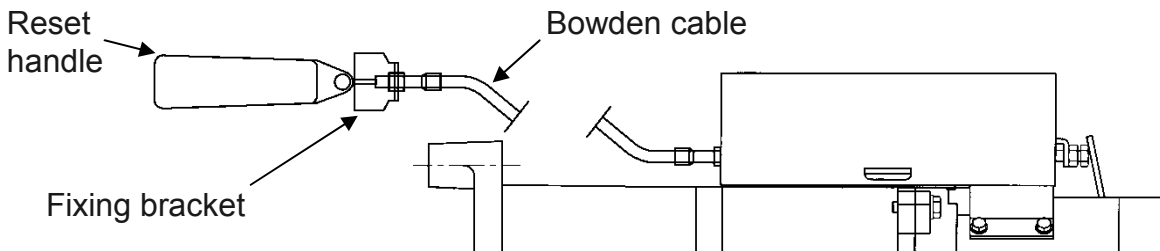

### 3. Level 1 fire - Fusible link.

The fusible link should be mounted in a suitable position so as the Bowden cable has a free and unrestricted operating path. The number and severity of turns in the cable should be kept to a minimum in order to obtain optimum performance. The minimum radius should be no less than 100mm.

It should be securely mounted either above the door canopy or onto the building structure.

The cable should be adjusted with the relevant adjusters either longer or shorter to obtain the correct operation once the path has been determined.

It should be operated several times to verify the operation is satisfactory.

- The operation should be checked both electrically & mechanically to determine that in both modes the cable is correct. Failure to do so may lead to operational failure. If the motor has a separate cover this should not impede the operation of the fusible link. It should also be accessible for routine testing as required.

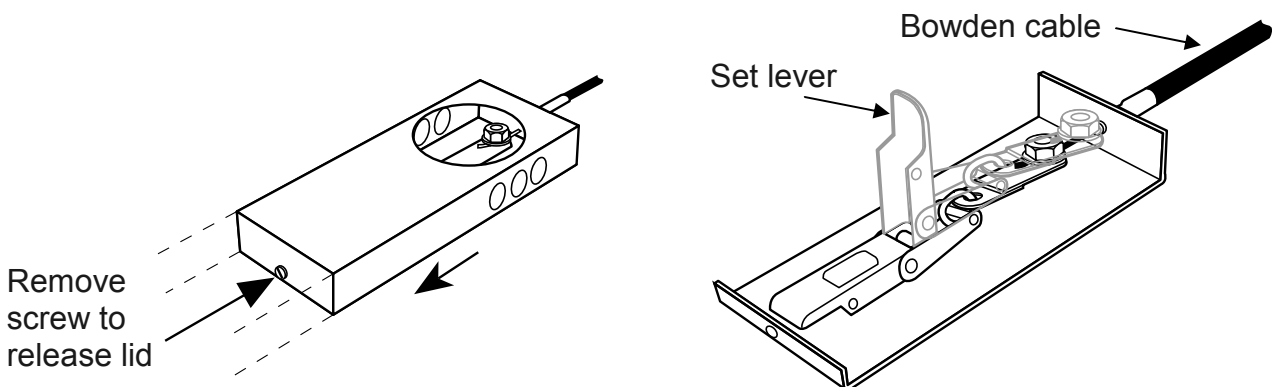

# Manual operation

The DLA150W drive is supplied with a single hand chain manual operator suitable for horizontal installation (chain is operated vertically).

### NOTE !

**Under no circumstances should the manual operator be engaged whilst the drive unit is being electrically operated. To do so will result in possible injury to personnel and / or damage to the manual operator system.**

To open the shutter with the manual operator proceed as follows:

1. Isolate the drive unit from the mains supply.
2. With the door stationary, pull the hand chain.
3. Releasing the chain automatically allows normal electrical operation.

Do not snatch the chain during manual operation as this may damage either the chain or the operator mechanism.

## Electrical details

Terminal box layout

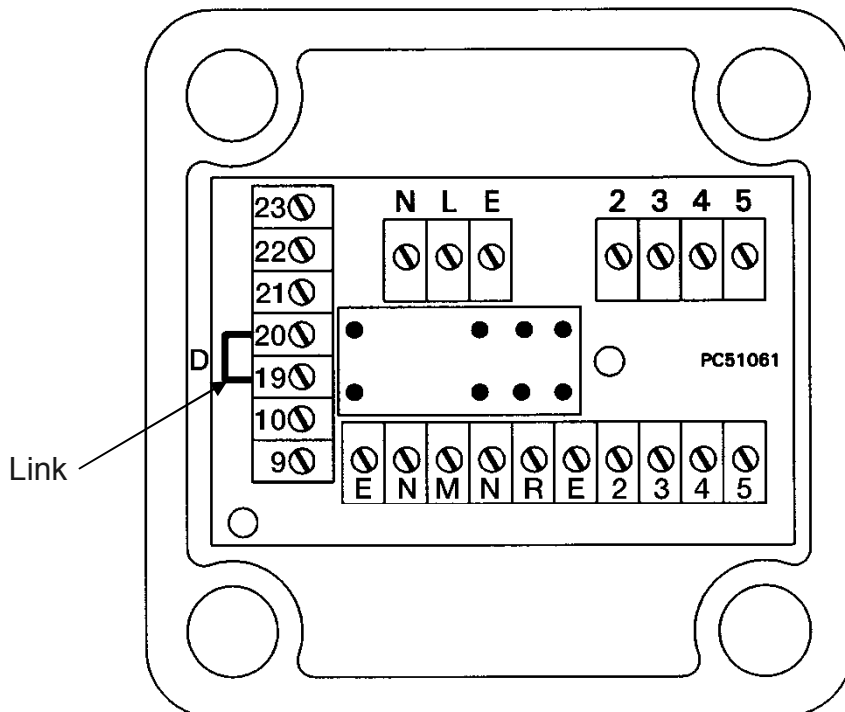

## Wiring a 3pb Station

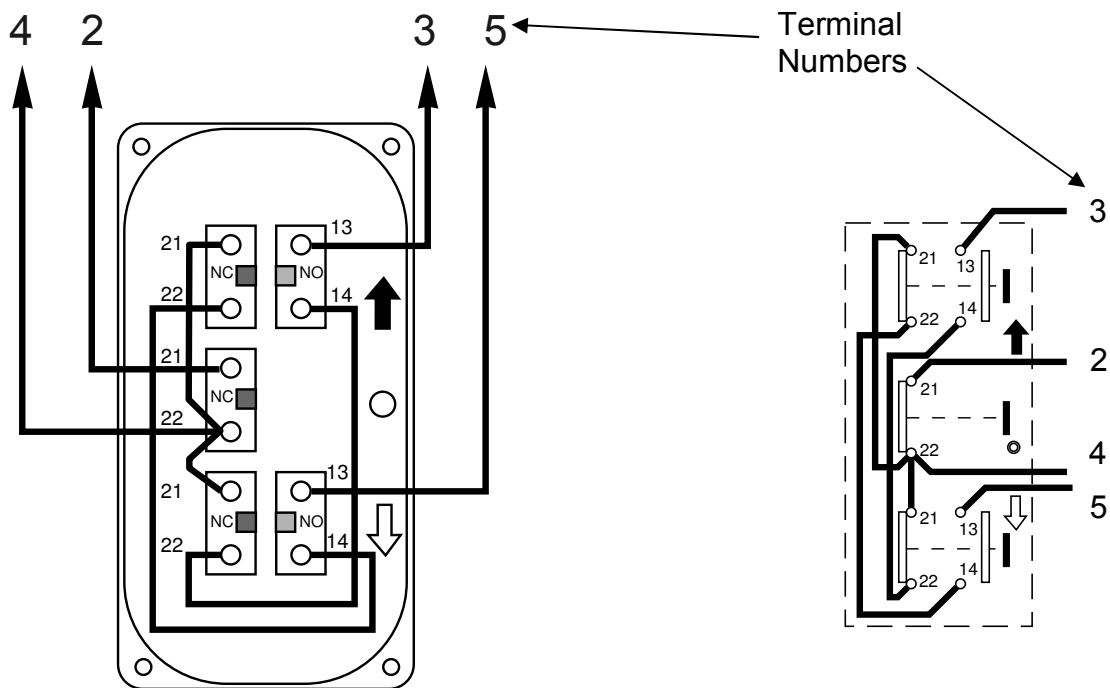

## Wiring an alarm signal

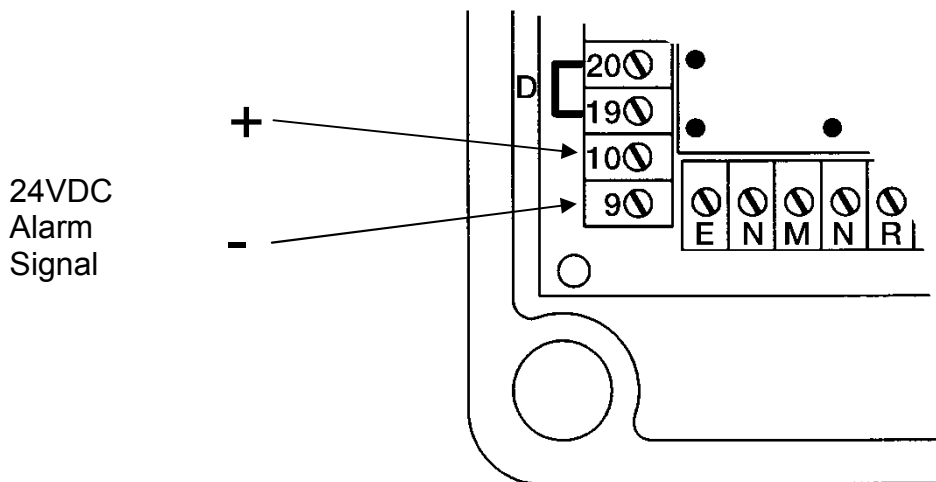

# Wiring 2 3pb Stations

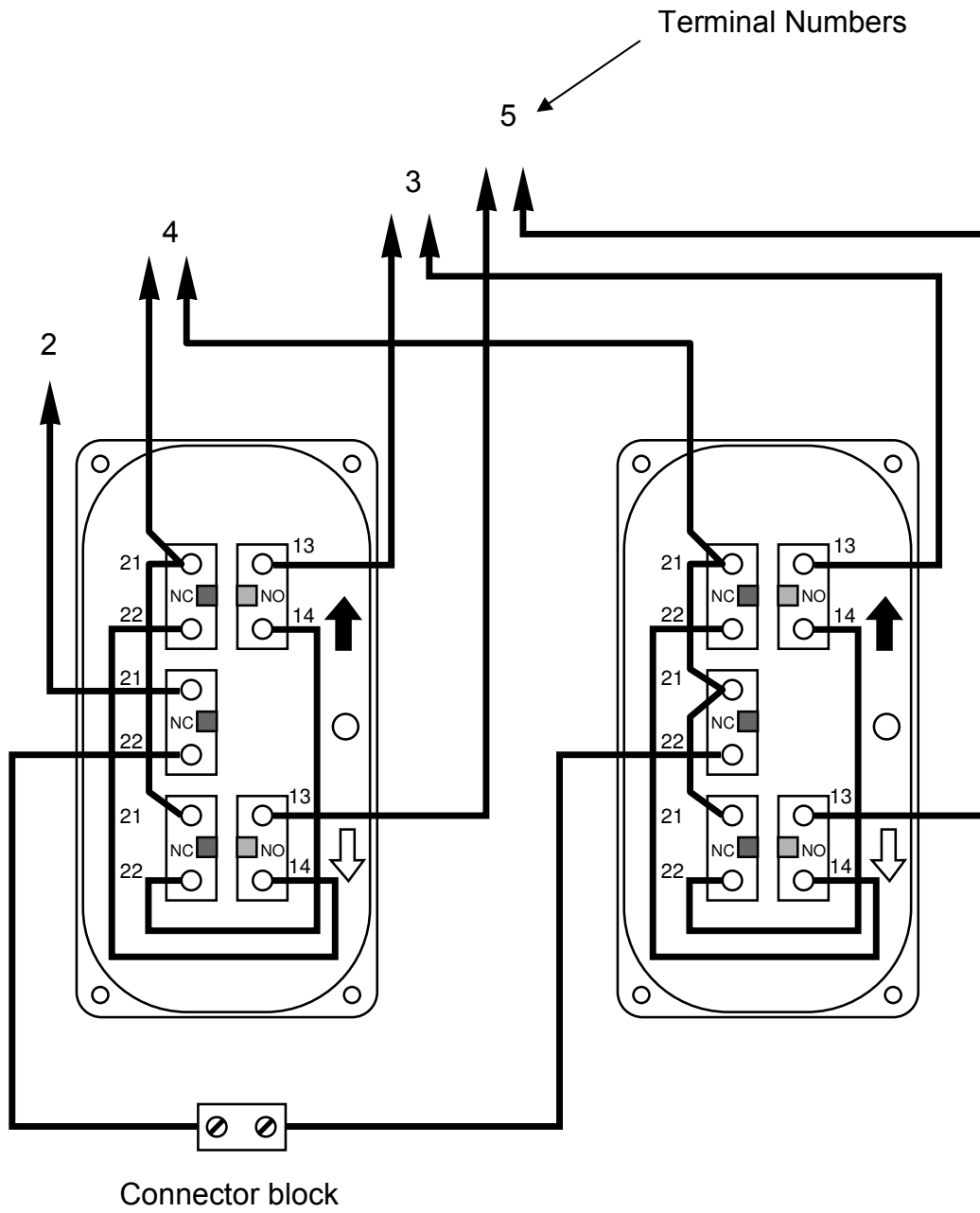

## Wiring a 2pb station

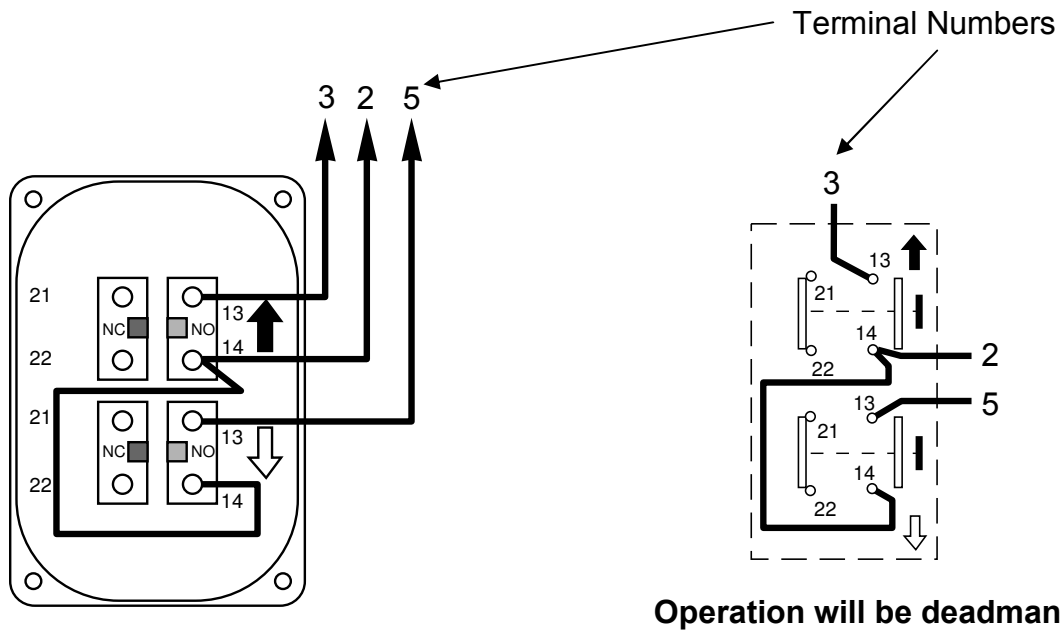

## Wiring a 3pb Station with Key switch (JAPZ4-IR or JEPZ4-IR)

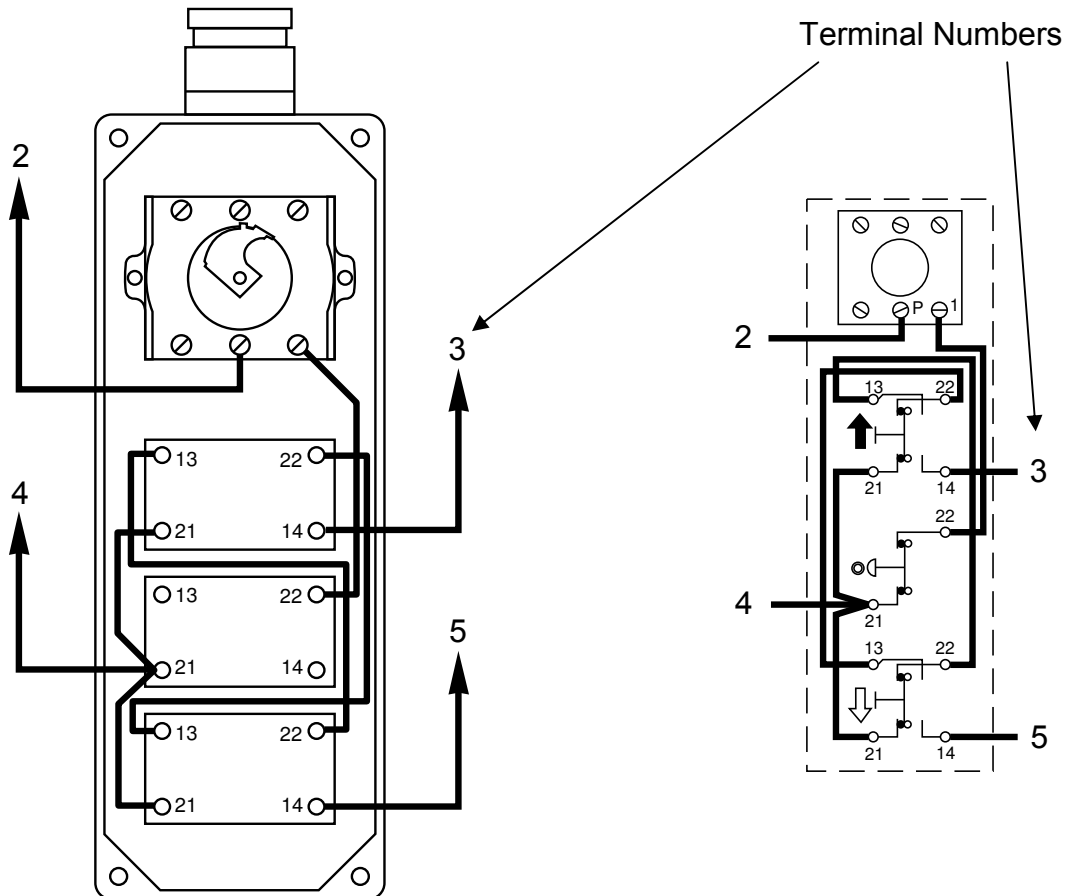



## Wiring a keyswitch (1-2T)

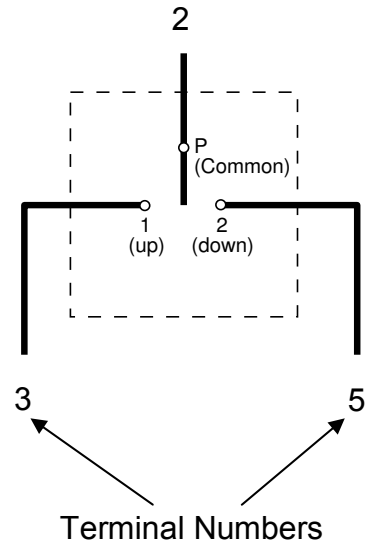
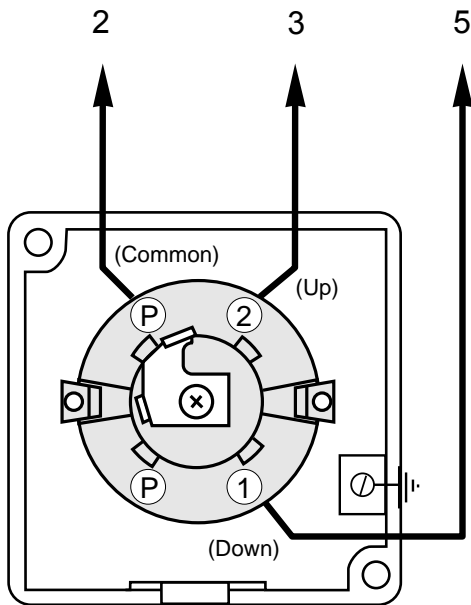

**Operation will be deadman**

# 150W Drive fitted with Alarm operated, automatic reset solenoid.

Drawing reference GDE51212/01

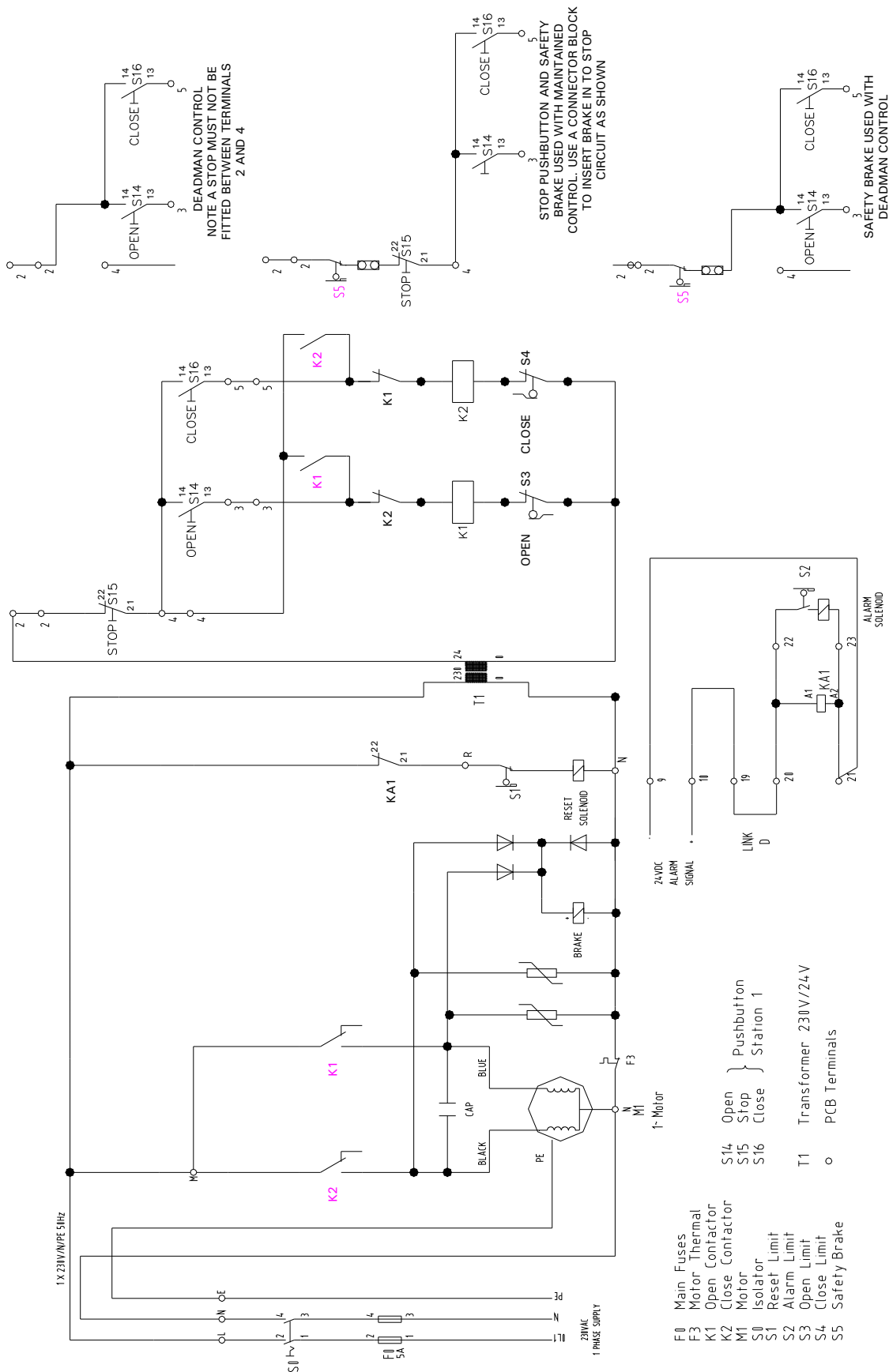

# 150W Drive fitted with Alarm operated, manually reset solenoid.

Drawing reference GDE51214/01

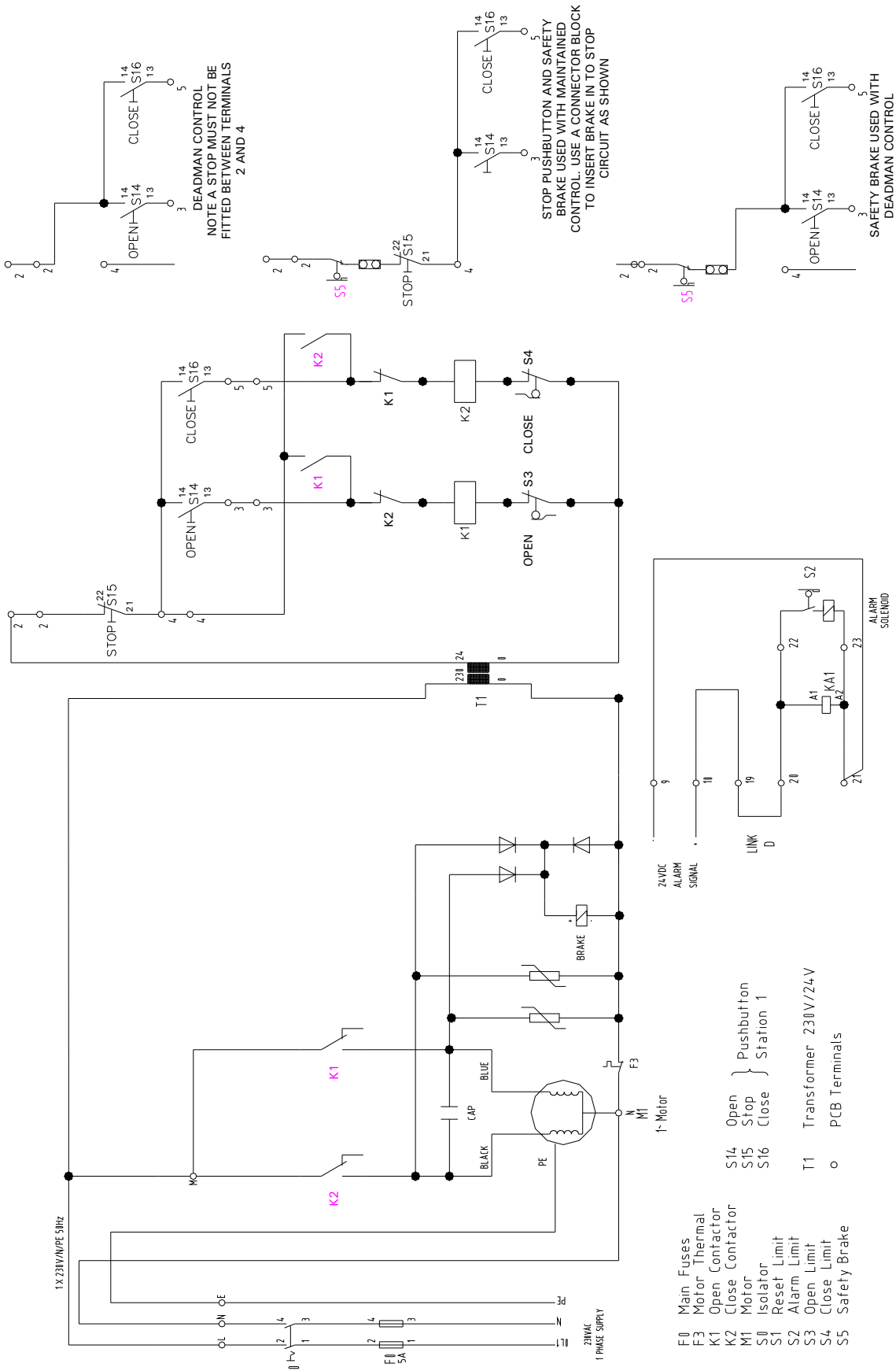

- F0 Main Fuses
- F3 Motor Thermal
- K1 Open Contactor
- K2 Close Contactor
- M1 Motor
- S0 Isolator
- S1 Reset Limit
- S2 Alarm Limit
- S3 Open Limit
- S4 Close Limit
- S5 Safety Brake
- S14 Open Pushbutton Station 1
- S15 Stop Pushbutton Station 1
- S16 Close Pushbutton Station 1
- T1 Transformer 230V/24V
- o PCB Terminals

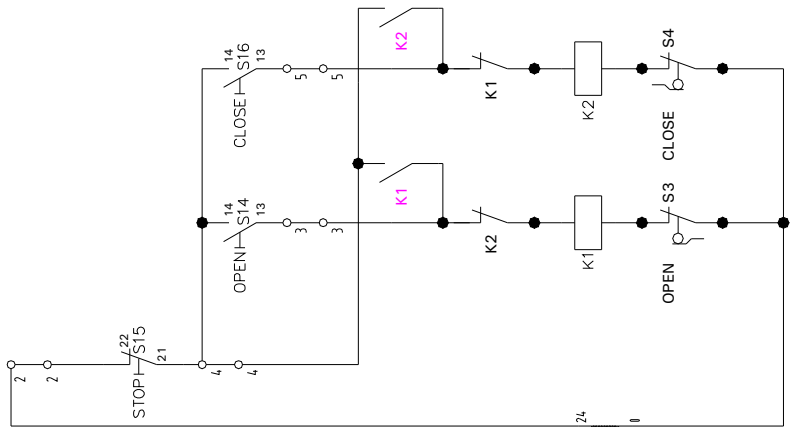
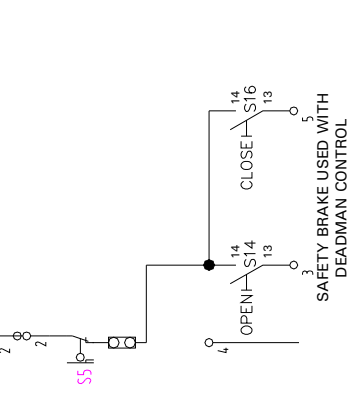
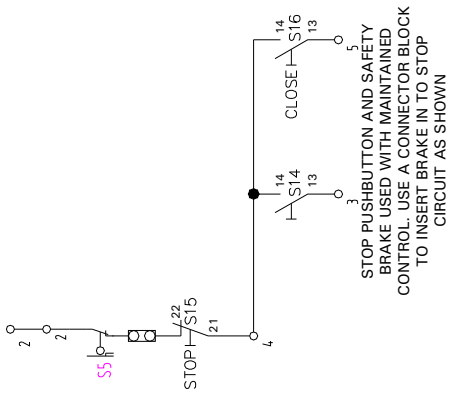
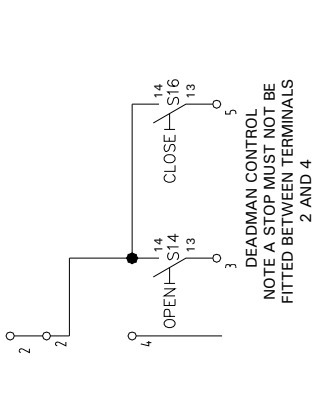

# 150W Drive fitted with Fusible link.

Drawing reference: GDE51216/01

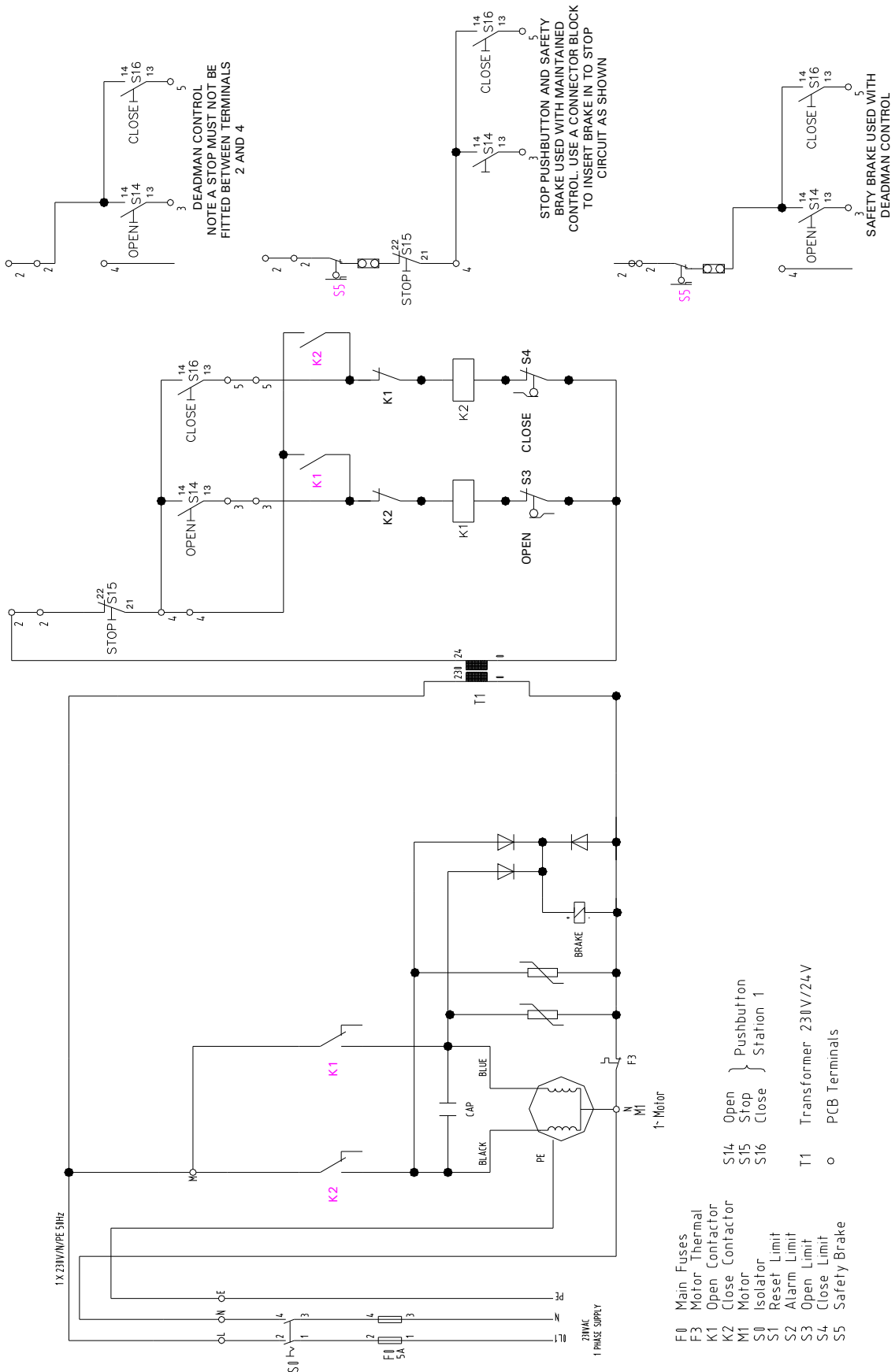

- F0 Main Fuses
- F3 Motor Thermal
- K1 Motor Contactor
- K2 Close Contactor
- M1 Motor
- S0 Isolator
- S1 Reset Limit
- S2 Alarm Limit
- S3 Open Limit
- S4 Close Limit
- S5 Safety Brake
- S14 Open Pushbutton
- S15 Stop Station 1
- S16 Close Station 1
- T1 Transformer 230V/24V
- o PCB Terminals

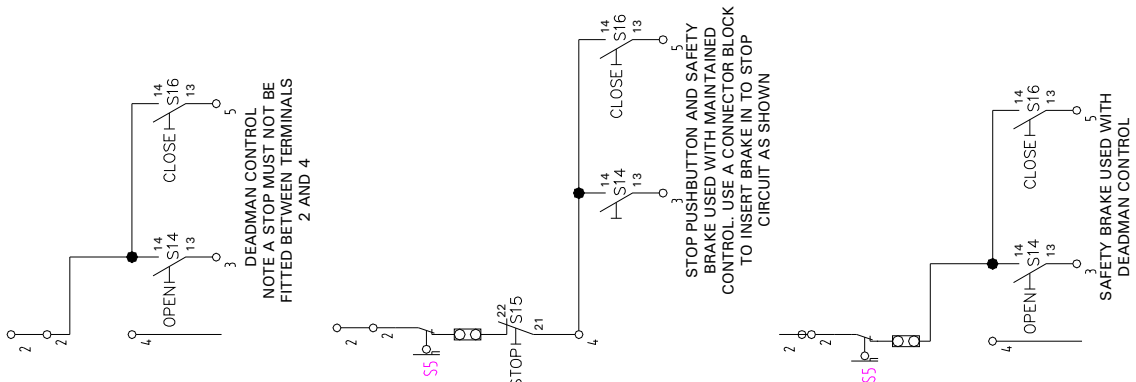

## To set the limit position

1. First identify your drive handing from the detail in fig 1. Then whilst setting the limit levers refer to the “right type” or “left type” instructions as required.

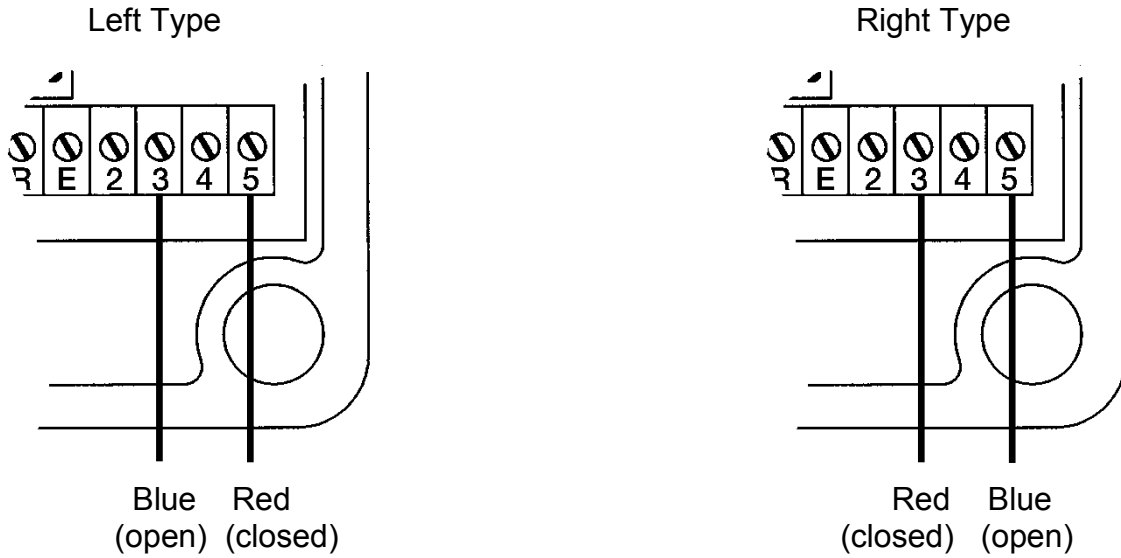

**Note:** All drive units are wired for Left Type. If your installation is Right type, exchange the red and blue command supply wires in the terminal box as shown.

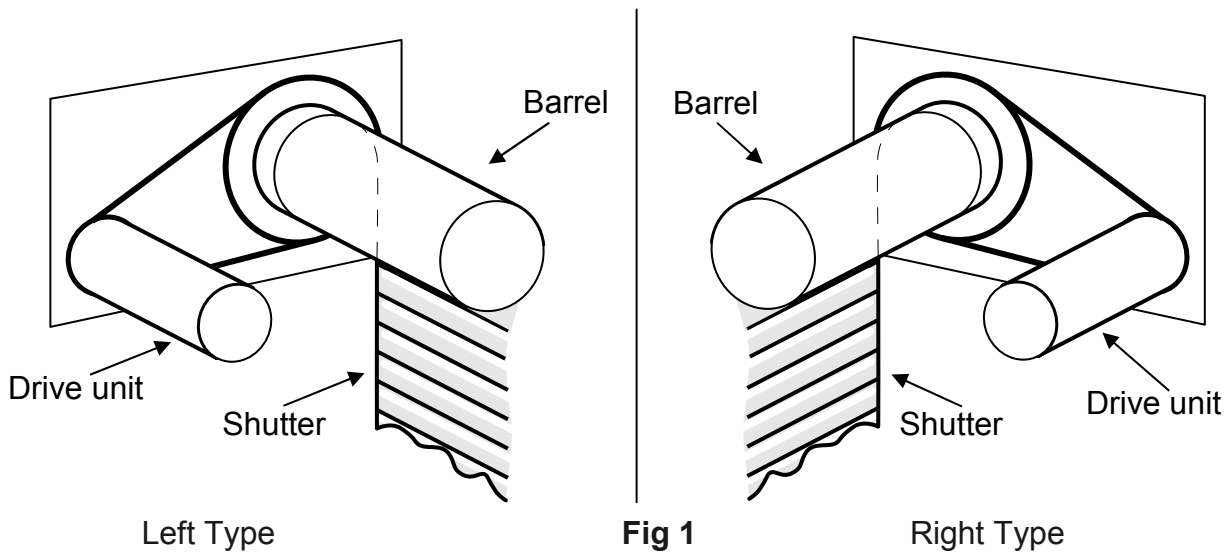

2. Move both the limit setting levers to the “before setting” position. See fig 2.

**Note !** With the levers in this position the drive does not have any limit stops.

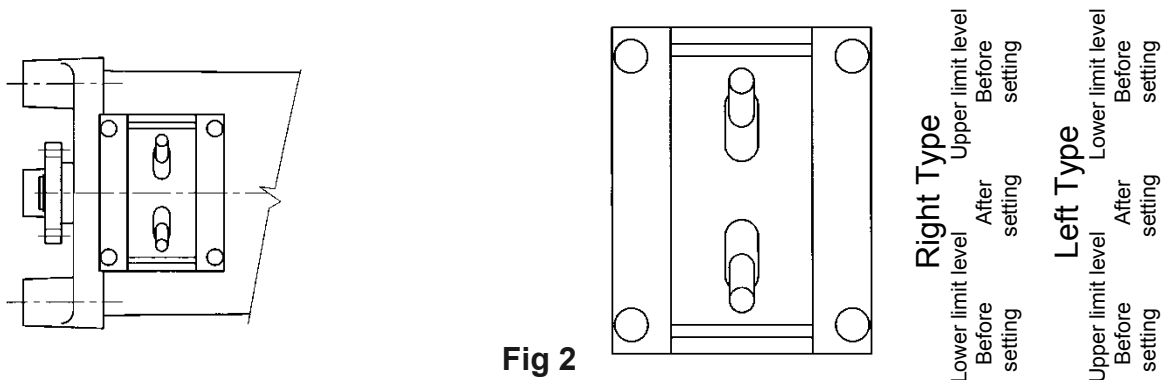

---

## To set the limit position

---

### For top limit position

3. Carefully operate the shutter to the position intended to be the upper limit.  
Select the correct lever (as identified in first stage of setting) and move the upper limit lever to the “after setting” position.
4. Drive the motor to close the shutter about 1m.  
Re-open the shutter and check the upper limit.

If the shutter does not stop as required, move the shutter to the required position then move the limit lever to the “before setting” position and back to the “after setting” position.

### For bottom limit position

5. Carefully operate the shutter to the position intended to be the lower limit.  
Select the correct lever (as identified in first stage of setting) and move the lower limit lever to the “after setting” position.
6. Drive the motor to open the shutter about 1m. Close the shutter and check the lower limit.  
If the shutter does not stop as required, move the shutter to the required position then move the limit lever to the “before setting” position and back to the “after setting” position.
7. Check both the upper and lower limit positions.

## GfA ELEKTROMATEN UK Ltd

### Declaration of Incorporation

In accordance with the Machinery Directive 2006/42/EC  
For a partly completed machine Appendix II Part B

Unit 1, Titan Business Centre, Spartan Close  
Warwick CV34 6RR, England.  
Telephone: 01926 452452 Fax: 01926 336417  
E-mail: sales@gfa-elektromaten.co.uk  
Web Site: www.gfa-elektromaten.co.uk

### Declaration of Conformity

In accordance with the EMC Directive 2014/30/EU, Low Voltage Directive 2014/35/EU

We

#### **GfA ELEKTROMATEN UK Ltd**

Declare that the product(s) specified below conform to the EU Directives stated above

**DLA150W, DLA250W, DLA500W, DLA600, DLA800 and DLA1000**

Harmonised Standards applied:

- |               |   |   |
|---------------|---|---|
| BS EN 60204-1 | - | Safety of machinery<br>Electrical equipment of machines<br>Part 1: General requirements |
| BS EN 60335-1 | - | Household and similar electrical appliances<br>Safety. General requirements             |

We undertake to transmit, in response to a reasoned request by the appropriate national authorities, relevant information on the partly completed machinery identified above.

Authorised representative for the compilation of the technical documentation

Howard Weaver – Principal Consulting Engineer

GfA ELEKTROMATEN UK Ltd

Partly completed machinery according to the Machinery Directive 2006/42/EC must not be put into service until the final machinery into which it is to be incorporated has been declared in conformity with the provisions of the directive.

Authorised Signature



Name: Andrew Collett

Title: Managing Director

Date

15-2-18

---

**Supplied by:**

**GfA ELEKTROMATEN UK Ltd**

Agincourt Road, Warwick,

CV34 6XZ United Kingdom

Telephone: 01 926 452452 Fax: 01 926 336417

E-mail: [sales@gfa-elektromaten.co.uk](mailto:sales@gfa-elektromaten.co.uk)

Web Site: [www.gfa-elektromaten.co.uk](http://www.gfa-elektromaten.co.uk)