

Darstellung: Einbaulage FU oben (FU seitlich s. Blatt 2)  
 Illustration: FI on the top (FI on the side: see sheet 2)

- Maß- und Konstruktionsänderungen vorbehalten  
 - Design and dimensions subject to change  
 - Sous réserves de toutes modifications techniques par le constructeur  
 - Con riserva di modifiche di dimensioni e costruzione  
 - Reservado el derecho a introducir modificaciones en las dimensiones y en la construcción

D	B	H	Nm	1/min
25,00	8,00	28,3	SI63 3,5.350 FU	35 30-350
25,40	6,35	28,4	SI63 5.250 FU	50 30-250
30,00	8,00	33,3	SI63 8.180 FU	80 30-180
31,75	6,35	34,7	SI 13.100 FU	130 18-100
35,00	10,00	38,3	SI 17.30 FU	170 8-30
40,00	12,00	43,3	SI 17.60 FU	170 8-60

Ind./Nr.	Dokumentenstatus	Ausgabedatum	Zulässige Abweichung	Geprüft	Datum	Name	Werkstoff	Maßstab	Format	Gewicht																										
D.1	Freigegeben	12.01.2023						1:2	DIN A0																											
<table border="1"> <thead> <tr> <th>Geprüft</th> <th>Datum</th> <th>Name</th> <th>Werkstoff</th> <th>div.</th> <th>Klassifikation</th> </tr> </thead> <tbody> <tr> <td></td> <td></td> <td></td> <td></td> <td></td> <td></td> </tr> </tbody> </table>							Geprüft	Datum	Name	Werkstoff	div.	Klassifikation							Benennung Einbaulage FU oben (FU seitlich s. Blatt 2)																	
Geprüft	Datum	Name	Werkstoff	div.	Klassifikation																															
<table border="1"> <thead> <tr> <th>Art</th> <th>Datum</th> <th>Ersteller</th> <th>Verwendungsbereich</th> <th>Art - /Zeichnungsnummer</th> <th>Blatt</th> </tr> </thead> <tbody> <tr> <td>SI</td> <td>12.01.2023</td> <td>SI</td> <td>GFA ELEKTROMATEN Wiesenstraße 81 40639 Düsseldorf Germany</td> <td>SI63 3,5.350 FU - SI 17.60 FU</td> <td>1/2</td> </tr> <tr> <td>h</td> <td>05.01.2016</td> <td>h</td> <td></td> <td>50001458</td> <td></td> </tr> <tr> <td>A</td> <td>11.01.16</td> <td>A</td> <td></td> <td></td> <td></td> </tr> <tr> <td>h</td> <td>01</td> <td>h</td> <td></td> <td></td> <td></td> </tr> </tbody> </table>							Art	Datum	Ersteller	Verwendungsbereich	Art - /Zeichnungsnummer	Blatt	SI	12.01.2023	SI	GFA ELEKTROMATEN Wiesenstraße 81 40639 Düsseldorf Germany	SI63 3,5.350 FU - SI 17.60 FU	1/2	h	05.01.2016	h		50001458		A	11.01.16	A				h	01	h			
Art	Datum	Ersteller	Verwendungsbereich	Art - /Zeichnungsnummer	Blatt																															
SI	12.01.2023	SI	GFA ELEKTROMATEN Wiesenstraße 81 40639 Düsseldorf Germany	SI63 3,5.350 FU - SI 17.60 FU	1/2																															
h	05.01.2016	h		50001458																																
A	11.01.16	A																																		
h	01	h																																		

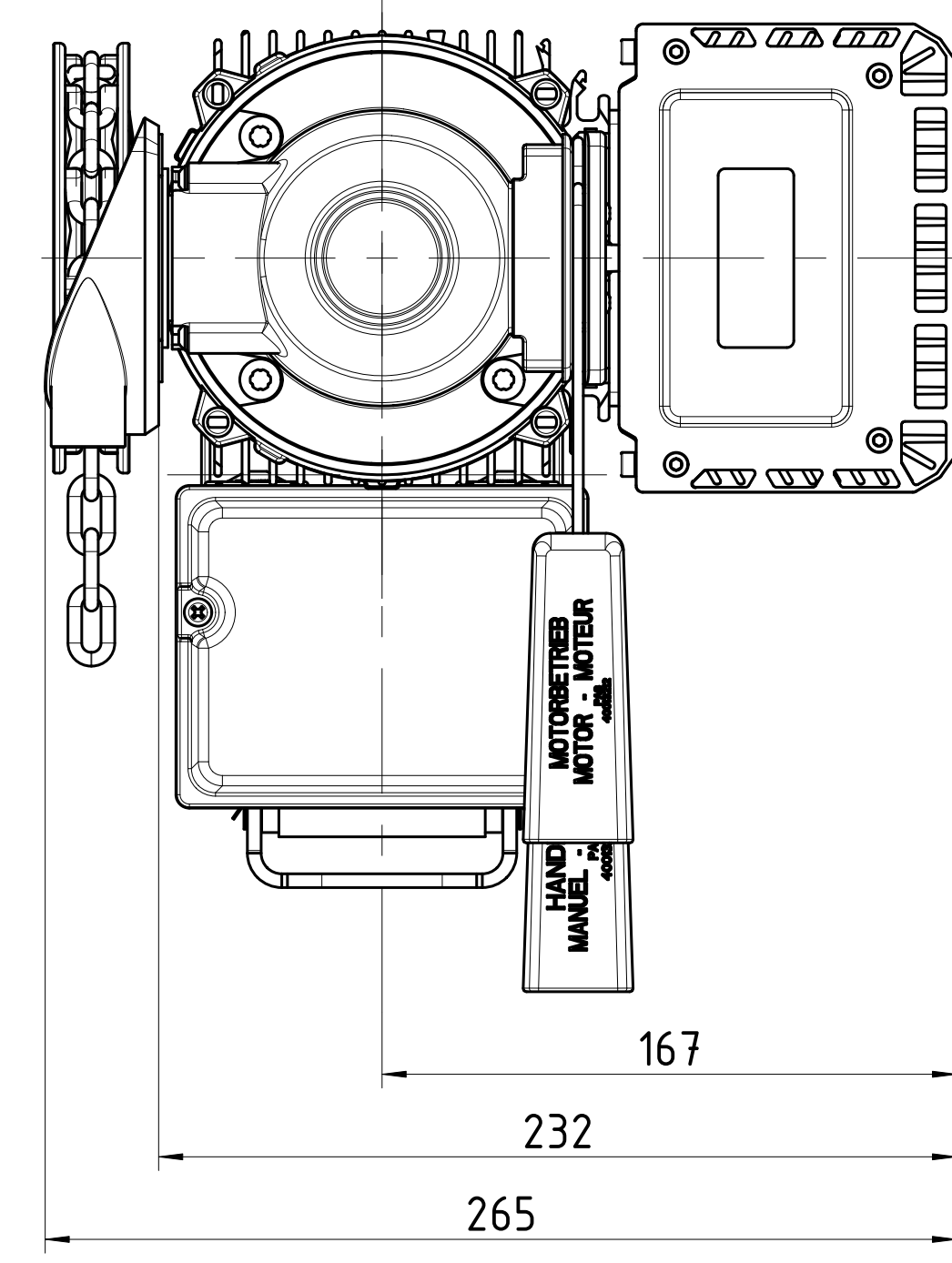
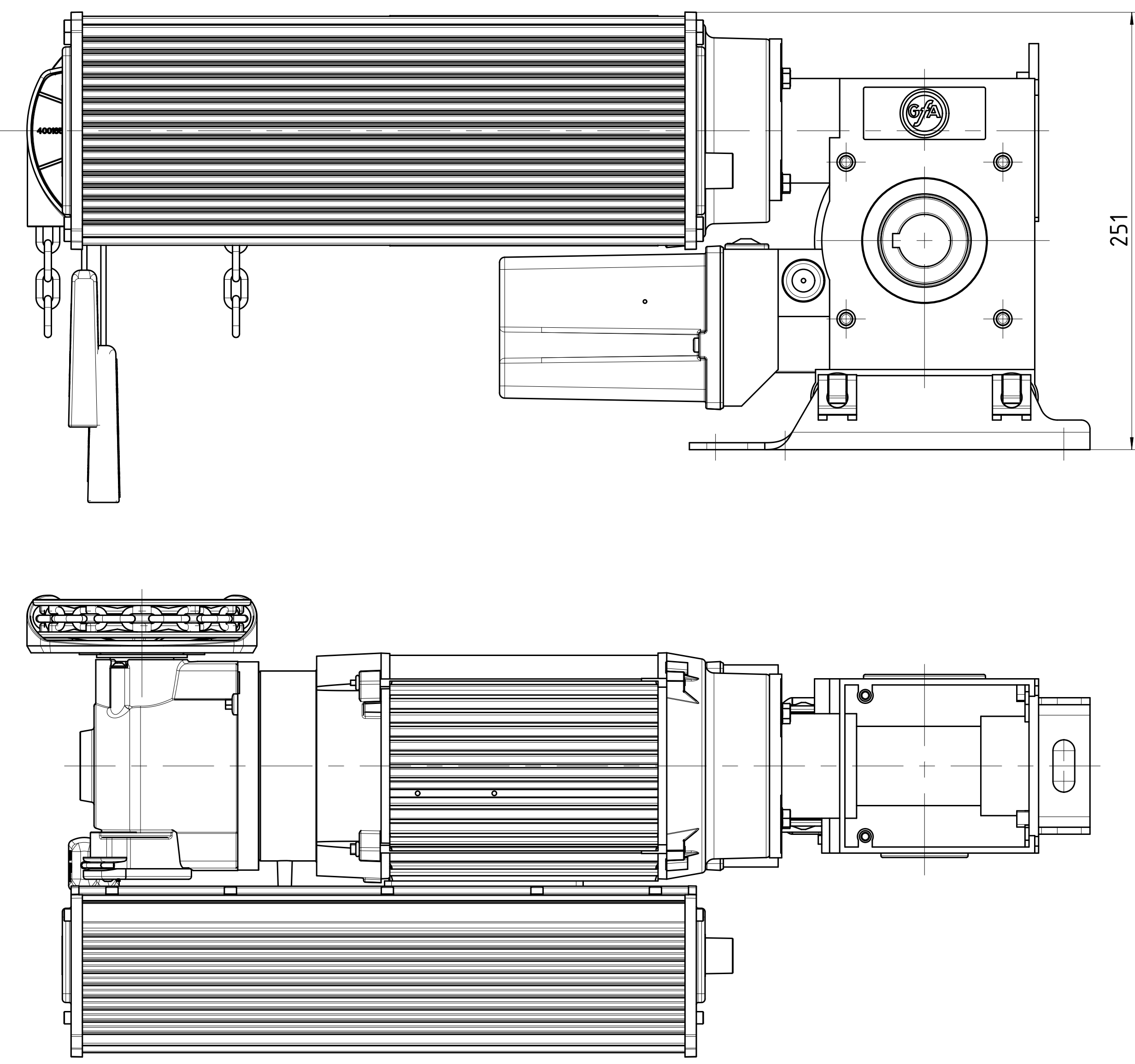

Darstellung: Einbaulage FU rechts  
illustration: FI on the right side

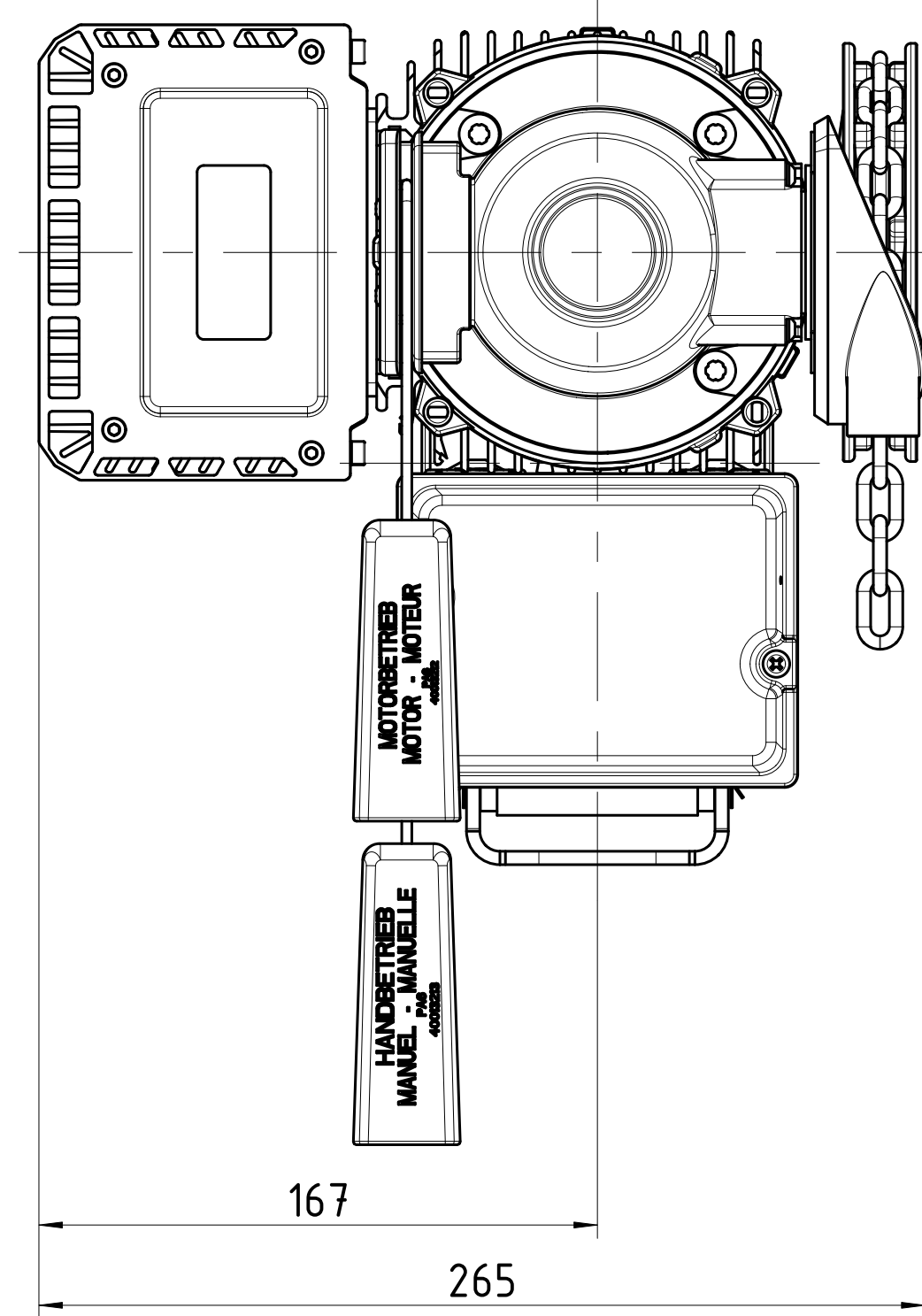
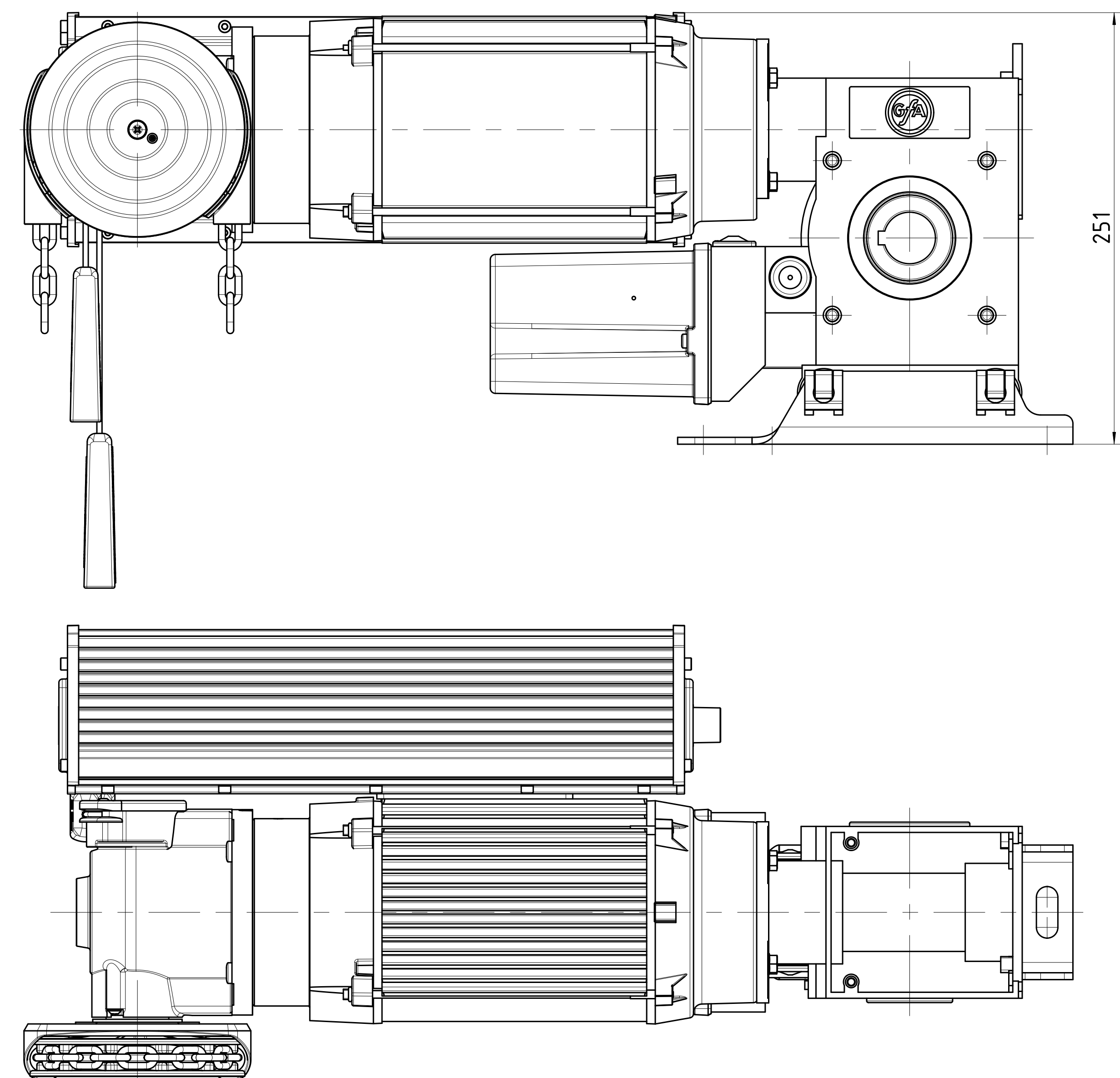
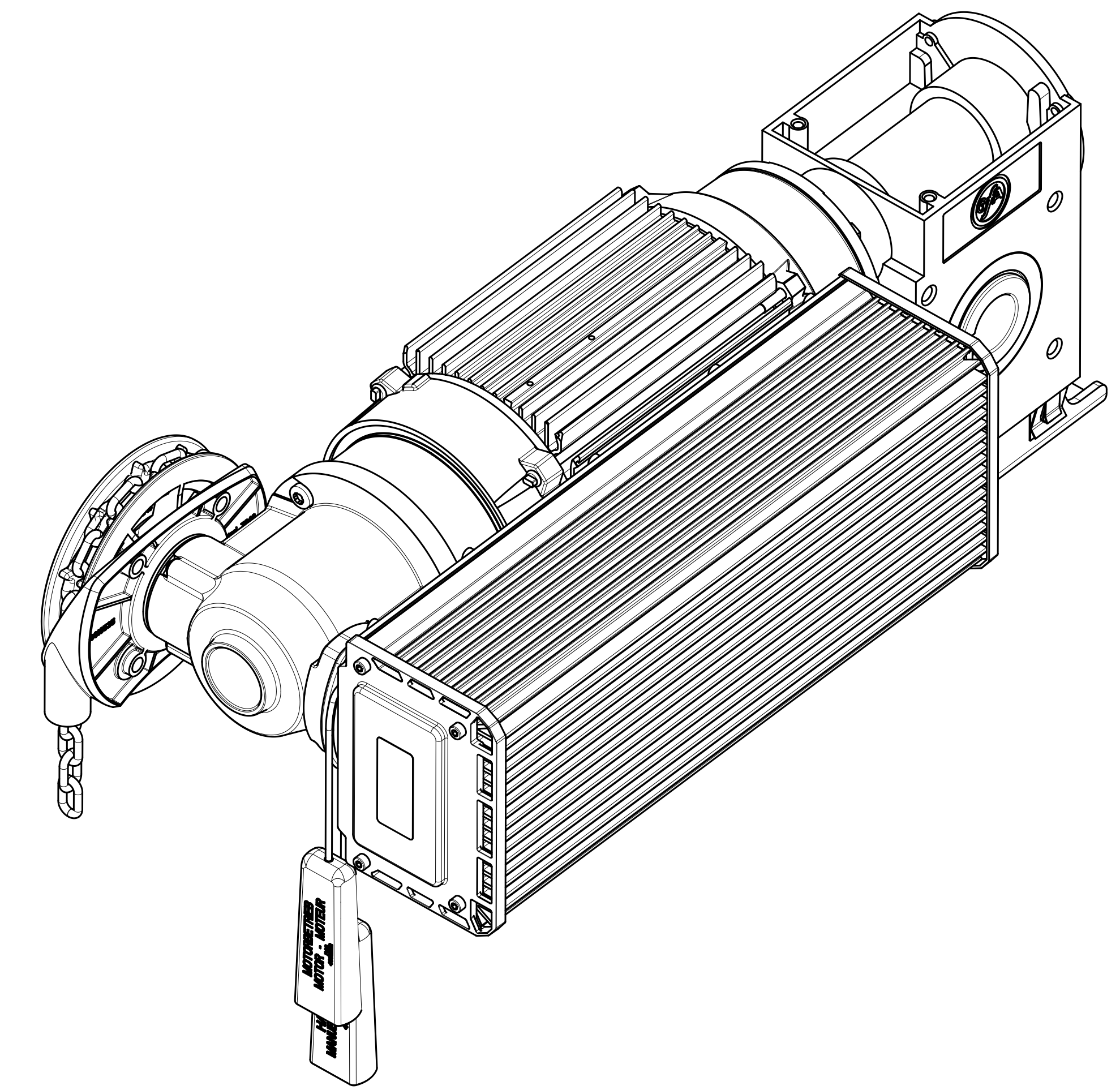

Darstellung: Einbaulage FU links  
illustration: FI on the left side

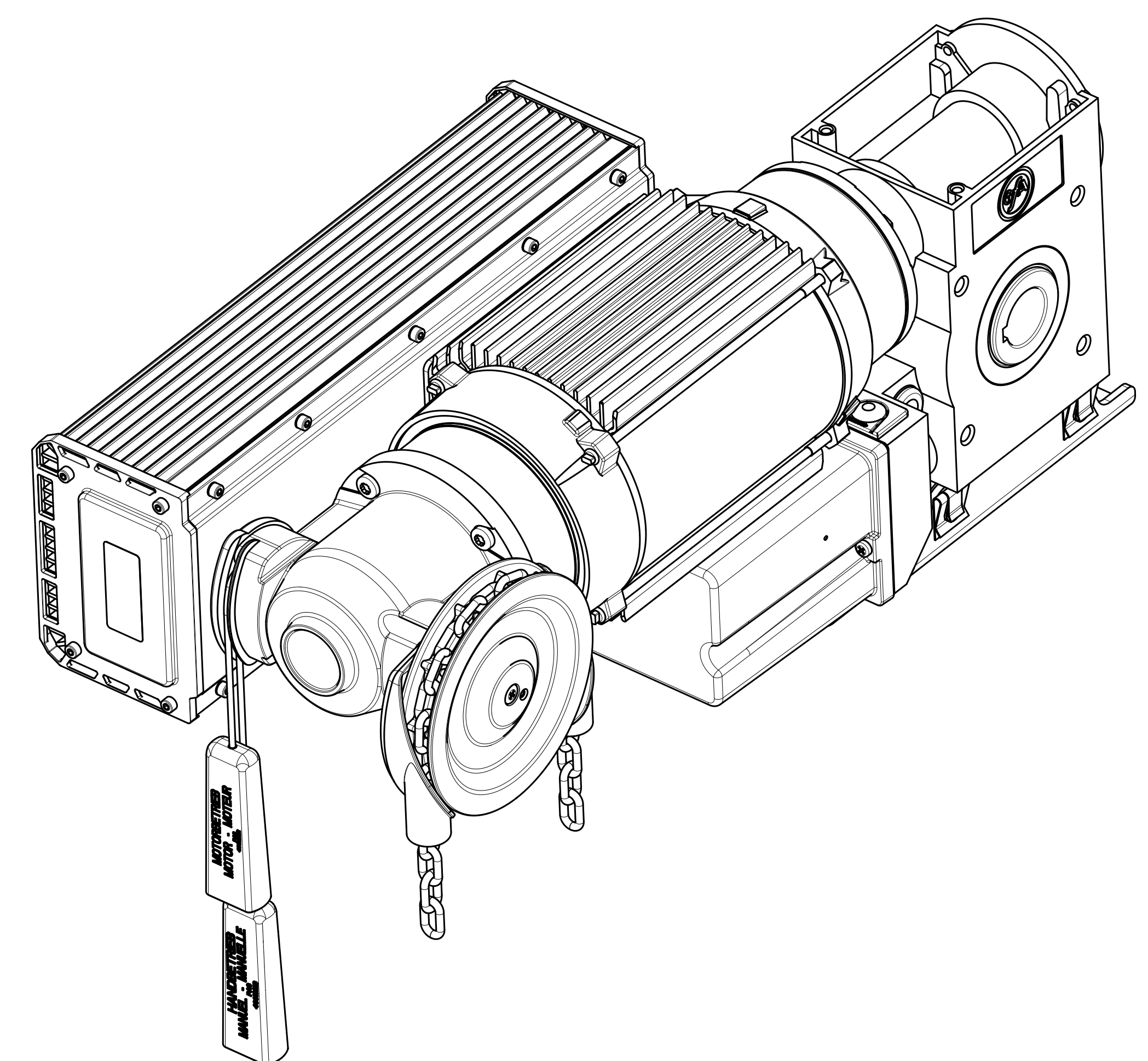

Ind./Nr.	Dokumentenstatus	Ausgabedatum	Zulässige Abweichung	Geprüft	Datum	Name	Werkstoff	Maßstab	Format	Gewicht	Klassifikation
D.1	Freigegeben	12.01.2023						1:1	DIN A0		D PP 446-10
				Geprüft			div.				
				Gezeichnet							
B	alte	18.01.2023	Neu								
C	alte	22.01.2023	Reise								
h	alte	05.01.2016	Reise								
A	H-191-16	17.01.16	Druck								
Ind.	Art	Datum	Ersteller	Verwendungs-bereich	50001458						