

1:10

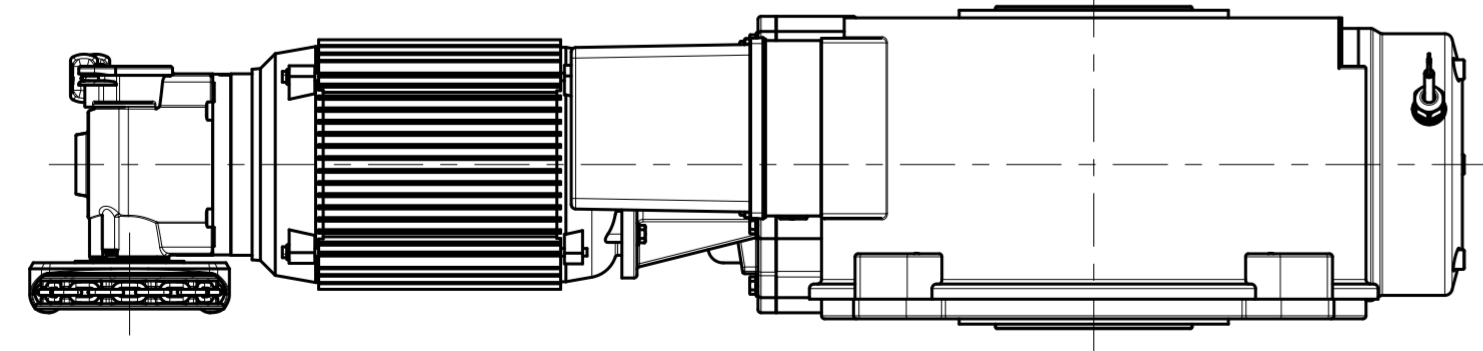
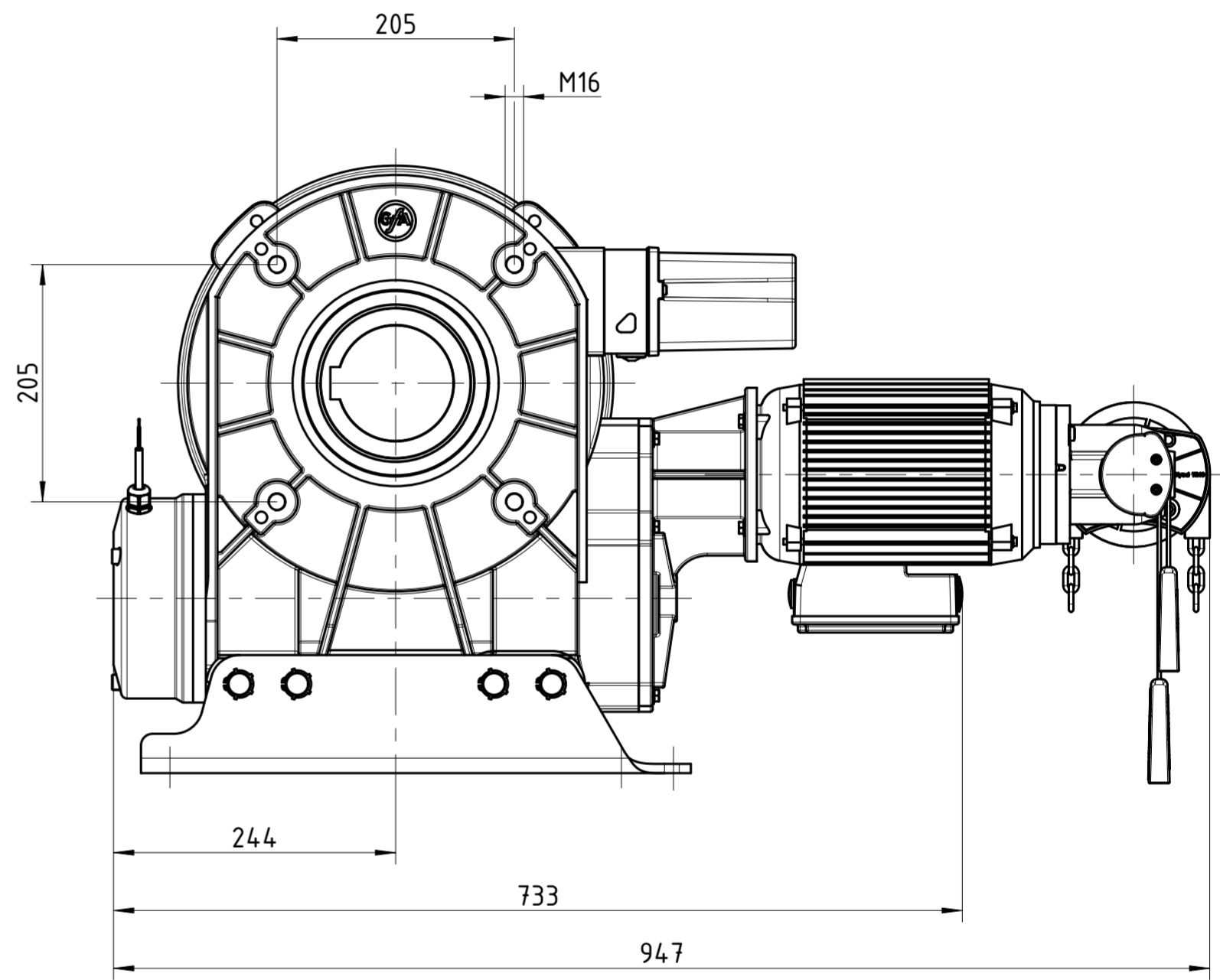
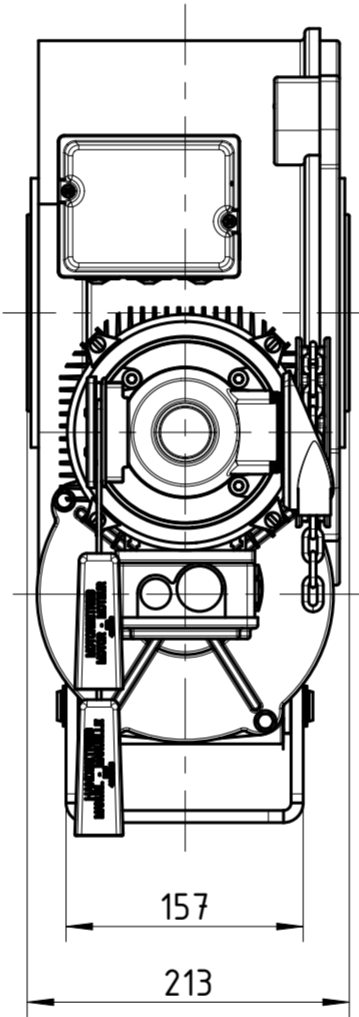
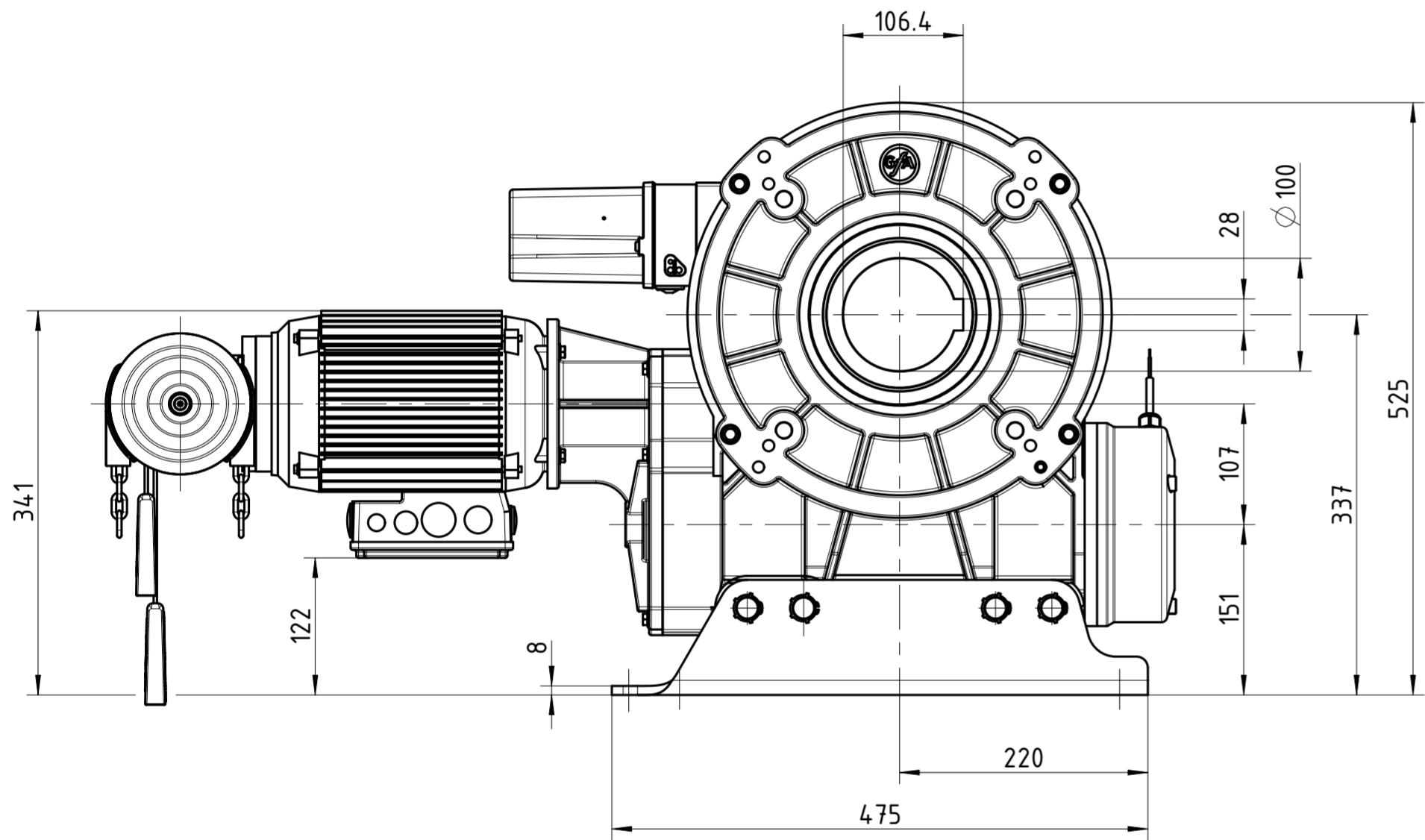

- Maß- und Konstruktionsänderungen vorbehalten
- Design and dimensions subject to change
- Sous réserves de toutes modifications techniques par le constructeur
- Con riserva di modifiche di dimensioni e costruzione
- Reservado el derecho a introducir modificaciones en las dimensiones y en la construcción

| | Art.-Nr. | Nm | 1/min |
|-------------|----------|------|-------|
| SI 500.5/GH | 10004344 | 5000 | 5 |

| | | | | | | |
|------------------|---------------------------------|----------------------------|----------------------------------|------------------------------|--|-------------------------------|
| Ind./Itr. A.1 | Dokumentenstatus Freigegeben | Ausgabedatum 12.05.2017 | Zulässige Abweichung QMW00033 | Maßstab 1:5 | Format DIN A2 | Gewicht |
| | | | Datum 12.05.2017 | Name Christoph | Werkstoff nach GfA Stückliste, bzw.: div. | Klassifikation 2 PP 446 01 |
| | | | Geprüft 12.05.2017 | Dimitrov | Benennung | |
| | | | | | Einbauzeichnung SG186F | |
| | | | | | SI 500.5/GH | |
| | | | | | Art.- / Zeichnungsnummer | Blatt |
| A | ohne | 12.05.2017 | Dimitrov | Verwendungsbereich SG186F | 50001997 | 1/1 |
| Ind. | ÄM | Datum | Ersteller | | | |

Prof/E - Dateiname: 50001997.dwg Schutzvermerk DIN ISO 16016 beachten / observe protective rights acc. to DIN ISO 16016