

ELEKTROMATEN® ST

Sliding-door-drive

For driving Sliding-doors

Series SG50R
ST 9.15 – ST 9.24

Series SG85R
ST 16.15 – ST 30.24

Series SG115R
ST 60.15 – ST 80.24

ELEKTROMATEN ST are special drives for sliding-doors designed for industrial use.

ELEKTROMATEN ST comprises of:

Worm gear with integrated friction clutch, interchangeable output-shaft, magnetic brake (optional), emergency manual operation (optional), integrated limit switch (optional), mounting accessories and electrical motor.

■ Output side:

Available with left- or rightside outputshaft

■ Friction clutch:

The integrated friction clutch guarantees impact-damped, low-wear operation.

■ Magnetic brake (optional):

Ensures precise positioning of the door limit position, slightly heating ensures trouble-free operation at low outside temperatures.

■ Integrated limit switch (optional): No need of separate limit switches

Approvals and certificates

ELEKTROMATEN

Type test according to:
DIN EN 12453
DIN EN 60335-1
DIN EN 60335-2-103

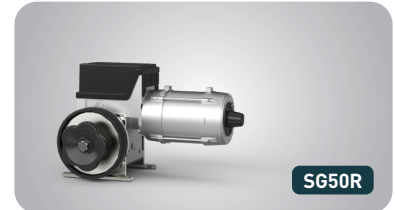

SG50R



SG85R



SG115R



1

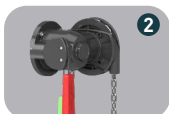

2



3



4

Emergency manual operation (optional)

- E.g.: for top-hung sliding doors
- Hand crank NHK
- Hand chain operator KNH

1

2

Limit switch integrated (optional)

Mechanical limit NES

- 2 operating, 2 emergency- and 2 auxiliary limit switches

3

Digital limit DES

- Absolute encoder, after a power failure, re-adjustment is not required

4

Separate limit switch (optional)

- Roller-arm limit switch
- Inductive limit switch

Mounting

- Foot angle (standard fitting)
- Mounting base

Special versions

- Increase of cycles per hour
- Other voltages and frequencies
- ST-TRK: Sliding-door ELEKTROMATEN with magnetic brake
- ST-SI: Sliding-door ELEKTROMATEN with integrated safety brake, e.g. for sliding doors operating on an incline

Door controls

- Simple connection by means of non-interchangeable plug connections allowing simple exchange with other GfA control panels
- Control voltage: 24 V
- Frequency: 50 Hz / 60 Hz
- Supply voltage: 1N~230 V, 3~230 V, 3N~400 V, 3~400 V

Details of all GfA door controls for sliding doors can be found from page 4.021.

1. Technical data

ELEKTROMATEN		ST 9.15	ST 9.24	ST 16.15	ST 16.24	ST 30.15
Series		SG50R	SG50R	SG85R	SG85R	SG85R
Output torque ¹⁾	Nm	90	90	160	160	300
Output speed	rpm	15	24	15	24	15
Max. door weight ¹⁾	N	9.000	9.000	16.000	16.000	30.000
Door speed ²⁾	cm/ sec	11	17	12	19	12
Output shaft / hollow shaft (Ø)	mm	25	25	40	40	40
Permitted OPEN / CLOSE output speed in frequency-inverter operating mode ³⁾	rpm	26 / 26	42 / 42	26 / 26	42 / 42	26 / 26
Motor power	kW	0,30	0,37	0,55	0,40	0,75
Supply voltage	V	3~230 / 400	3~230 / 400	3~230 / 400	3~230 / 400	3~230 / 400
Operating frequency	Hz	50	50	50	50	50
Operating current ⁴⁾	A	2,6 / 1,5	2,1 / 1,2	3,1 / 1,8	3,1 / 1,8	5,1 / 3,0
Max. cycles per hour ⁵⁾		8 (2,1)	12 (10,4)	11 (6,2)	11 (5,6)	10 (4,2)
Limit switch range ⁶⁾		20 (40)	20 (40)	20 (40)	20 (40)	20 (40)
Weight	kg	16	16	32	31	34
Spare parts: Catalogue page		9.051	9.051	9.055	9.055	9.055
Part no. installation drawing (dxf, dwg)		50000976	50000976	50000929	50000929	50000929
Part no. ELEKTROMATEN		10003371	10002917	10003372	10002992	10003373

ELEKTROMATEN		ST 30.24	ST 60.15	ST 60.24	ST 80.15	ST 80.24
Series		SG85R	SG115R	SG115R	SG115R	SG115R
Output torque ¹⁾	Nm	300	600	600	800	800
Output speed	rpm	24	15	24	15	24
Max. door weight ¹⁾	N	30.000	60.000	60.000	80.000	80.000
Door speed ²⁾	cm/ sec	19	12	19	12	19
Output shaft / hollow shaft (Ø)	mm	40	50	50	50	50
Permitted OPEN / CLOSE output speed in frequency-inverter operating mode ³⁾	rpm	42 / 42	26 / 26	42 / 42	26 / 26	42 / 42
Motor power	kW	0,85	1,10	1,50	1,10	2,00
Supply voltage	V	3~230 / 400	3~230 / 400	3~230 / 400	3~230 / 400	3~230 / 400
Operating frequency	Hz	50	50	50	50	50
Operating current ⁴⁾	A	4,4 / 2,6	7,2 / 4,2	6,7 / 3,9	7,0 / 4,1	8,1 / 4,7
Max. cycles per hour ⁵⁾		11 (5,6)	9 (3,0)	11 (6,9)	6 (1,0)	12 (8,3)
Limit switch range ⁶⁾		20 (40)	20 (60)	20 (60)	20 (60)	20 (60)
Weight	kg	32	53	49	56	56
Spare parts: Catalogue page		9.055	9.056	9.056	9.056	9.056
Part no. installation drawing (dxf, dwg)		50000929	50001311	50001311	50001311	50001311
Part no. ELEKTROMATEN		10002993	10003340	10003259	10003374	10003195

Generally applies: Degree of protection IP54, permissible temperature range -10 °C...+40 °C (+60 °C), from -20 °C in combination with a permanently used magnetic brake, operating sound pressure level SPL <70 dB(A)

1) See 2.6 · 2) Door speed when operated with standard chain wheel, see 5.3 · 3) We recommend the selection of a special ELEKTROMATEN (enquire) for use with frequency inverter, OPEN drive speed at 87 Hz, see 2.6 and 2.7 · 4) The operating current in door drives can reach up to 4x the rated current for limited periods, see 2.7 and 2.8 · 5) One cycle consists of a complete opening and closing movement of the door. The value according to EN 60335-2-103 is given in brackets. If the limit switch range is not fully used, the number of possible cycles can be increased in relation to the reduced number of revolutions of the output shaft, see also 2.2 · 6) Maximum possible revolutions of output-shaft with integrated limit switch, see 2.9

2. Notes

2.1 European directive

In accordance with the product standard EN 13241 Doors- and EN 12453 Safety in use of power operated doors-Requirements.

2.2 Cycles per hour

The specified cycles per hour (see technical data) apply to even distribution and the limit switch range first mentioned. When using the temperature range +40 °C to +60 °C, the specified value must be halved. For other limit switch ranges, the values must be converted accordingly.

2.3 Magnetic brake

The optional magnetic brake locks the output-shaft when the motor is switched off. The magnetic brake ensures precise positioning of the door in the limit position and avoids over-running the limit position of the door. Slight heating ensures trouble-free operation at low outside temperatures.

2.4 Gear self-braking / Brake

Drives without an electric brake have a self-sustaining worm gear and stop automatically.

On drives with an electric brake, stopping is achieved by the external brake. Brake inspection must always be carried out by qualified service engineers.

2.5 Manual operation

In the event of power failure, the door can be opened by hand after releasing the friction clutch. Emergency manual operation by crank handle or chain is also available as an option (e.g. for top-hung sliding doors).

2.6 Output torque / Door weight / Friction clutch

The integrated slipping clutch guarantees impact-damped, low-wear operation. The admissible output torque is pre-adjusted. If the clutch is subject to higher forces than the admissible (e.g. the possibility of attempted forced entry) additional improvements of the door design may be required to prevent undesired opening of the door. The weights indicated apply to horizontal, rail-mounted sliding doors.

2.7 Motor overload protection

Motor overload protection must be able to withstand 4x the operating motor current because the starting current of the drive unit can reach these levels for short periods.

2.8 Use with external frequency inverter

For external frequency inverters applies:

A higher than recommended drive speed puts extra load onto the gear. This extra load must be taken into account when sizing a drive by reducing the available output torque..

The admissible drive speeds may not be exceeded (see Technical data). The operating forces must comply with EN 12453, and the corresponding EMC directives must likewise be observed.

If selecting a frequency inverter, note that the starting current of the drive unit can reach 4x of the operating motor current.

2.9 Integrated limit switch

The door construction should be designed to prevent the disengaging of drive elements (sprocket, chain, rack etc.).

The stopping accuracy of the ELEKTROMATEN ST with magnetic brake and a limit switch range of E20 is approximately +/- 15 mm (for E40, approx. +/- 25 mm). The door construction must be designed to compensate onsite these differences (e.g. height- of the rubber profile of the safety edge).

For higher requirements regarding stopping accuracy, we recommend the use of separate limit switches (roller-arm limit switches, inductive limit switches, etc.).

3. Dimensions

3.1 ST 9.15 – ST 9.24

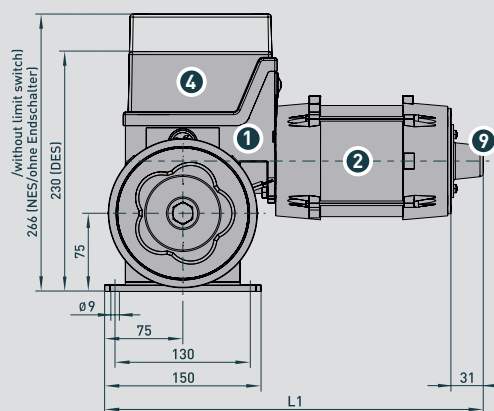
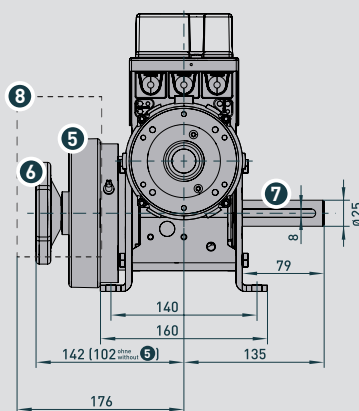

SG50R

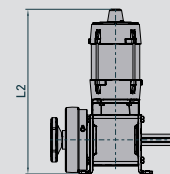
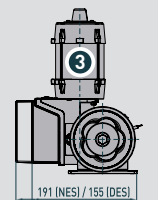

- 1 Worm gear with friction clutch
- 2 Motor horizontal / 3 Motor vertical
- 4 Terminal box / optional: Integrated limit switch
- 5 Magnetic brake
- 6 Hand wheel for friction clutch adjustment
- 7 Output-shaft right (optional: Left)
- 8 Optional: WS 905 control panel
- 9 Cover

ELEKTROMATEN	L1	L2
ST 9.15	344	344
ST 9.24	364	364

■ Permitted installation: Horizontal (as shown) or vertical (motor to the top)



3.2 ST 16.15 – ST 30.24

SG85R

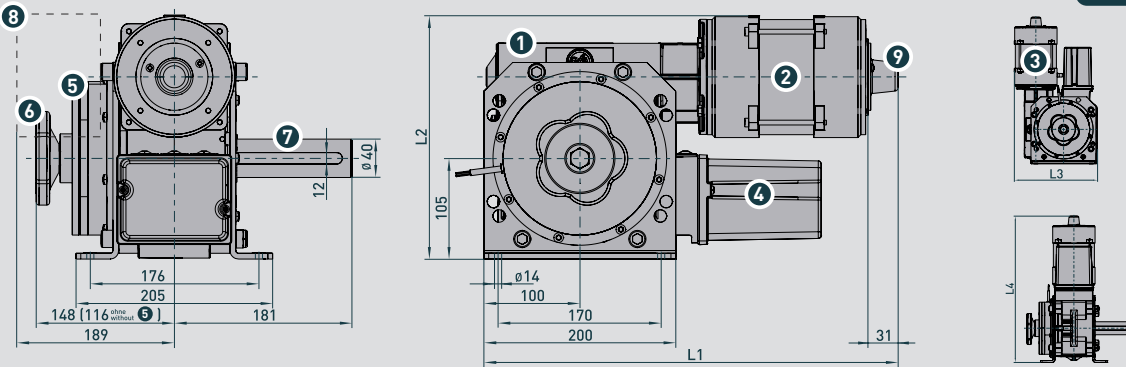

- 1 Worm gear with friction clutch
- 2 Motor horizontal / 3 Motor vertical
- 4 Terminal box / optional: Integrated limit switch
- 5 Magnetic brake
- 6 Hand wheel for friction clutch adjustment
- 7 Output-shaft right (optional: Left)
- 8 Optional: WS 905 control panel
- 9 Cover

ELEKTROMATEN	L1	L2	L3	L4
ST 16.15	461	263	262	466
ST 16.24	431	254	253	436
ST 30.15	489	263	262	494
ST 30.24	461	263	262	466

■ Permitted installation: Horizontal (as shown) or vertical (motor to the top)

3.3 ST 60.15 – ST 80.24

SG115R

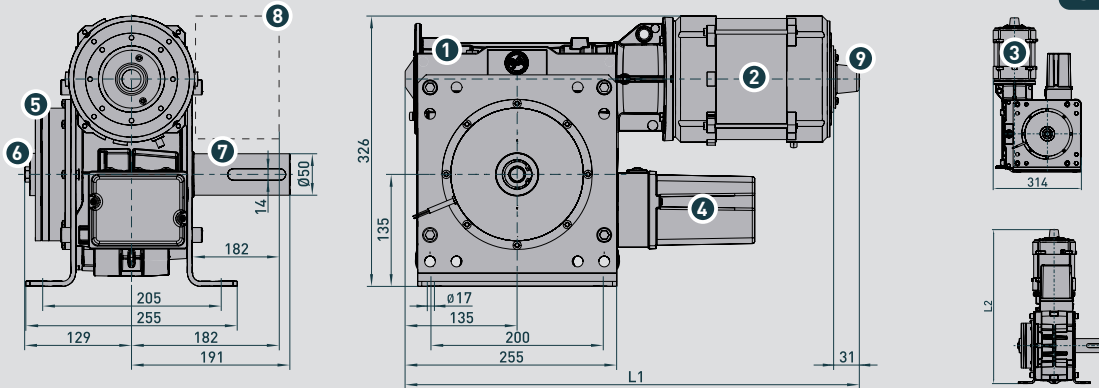

- 1 Worm gear with friction clutch
- 2 Motor horizontal / 3 Motor vertical
- 4 Terminal box / optional: Integrated limit switch
- 5 Magnetic brake
- 6 Friction clutch adjustment (SW 17)
- 7 Output-shaft right (optional: Left)
- 8 Optional: WS 905 control panel
- 9 Cover

ELEKTROMATEN	L1	L2
ST 60.15	567	567
ST 60.24	542	542
ST 80.15	587	587
ST 80.24	567	567

■ Permitted installation: Horizontal (as shown) or vertical (motor to the top)

4. Emergency manual operation • optional

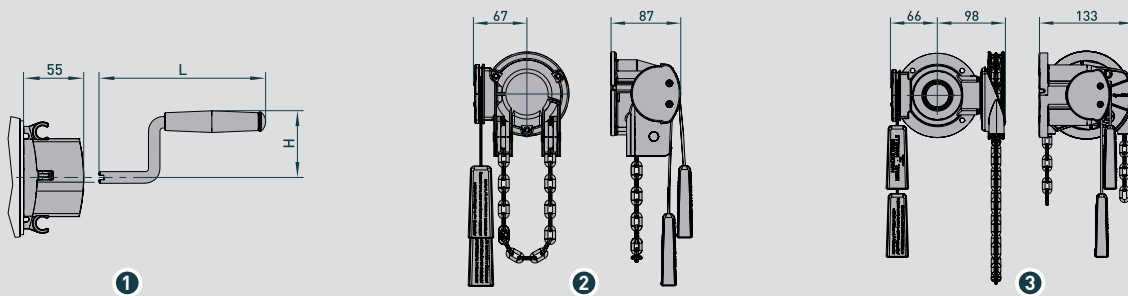

- 1 Hand crank operation NHK
- 2 Rapid hand chain operator SK (→ SG50)
- 3 Hand chain operator KNH (→ SG85 / SG115)

	For Series	Part no.	∅	L	H
1	SG50	30002591	10	255	92
1	SG85	30002749	12	235	122
1	SG115	30003112	12	265	192

■ Read note in 2.5

5. Attachments/Accessories

5.1 Mounting base

→ ST 9.15 – ST 30.24

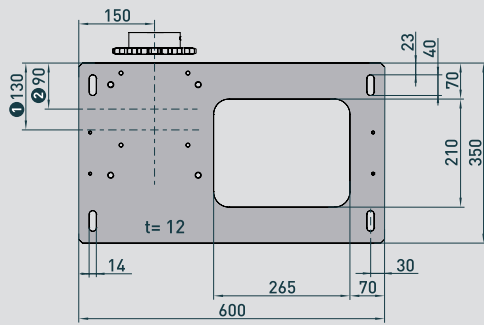

1 ST 16.15 – 30.24

2 ST 9.15 / 9.24

- Part no. 30004214
- Right- or left-hand use

5.2 Housing

→ ST 9.15 – ST 30.24

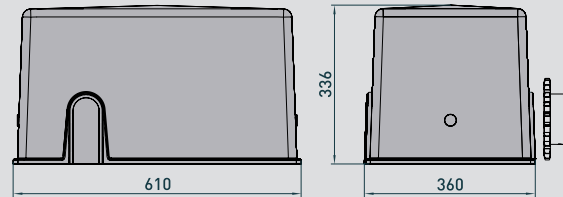

Housing

- Part no. 30004215
- Right- or left-hand use

Locking cpl. for housing

- Part no. 30004266
- 2 units

5.3 Sprockets/roller chains

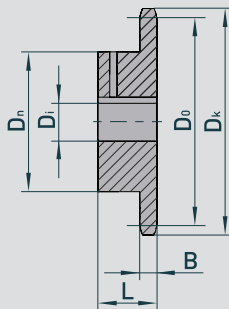

1

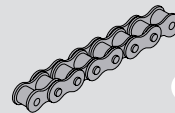
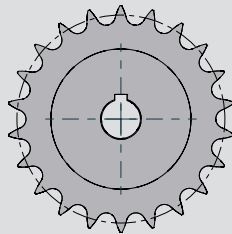

2

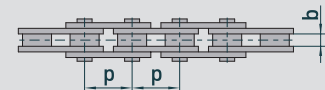

Chain (p x b) 2	Description	Part no.
12 B-1 (3/4" x 7/16") (19,05 mm x 11,68 mm)	2,0 m	40003030
	5,0 m	40013909
	Link	40000615
16 B-1 (1" x 17,02 mm) (25,4 mm x 17,02 mm)	2,5 m	40005049
	5,0 m	40013910
	Link	40000617

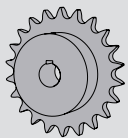

Sprockets for ELEKTROMATEN 1	Designation	Teeth's	Part no.	D _k	D _o	D _n	D _i	B	L
ST 9.15 / ST 9.24	12 B-1 (3/4" x 7/16")	22	30000213	141,8	133,9	90	25	11,1	40
ST 16.15 – ST 30.24	16 B-1 (1" x 17,02 mm)	19	30000321	165,2	154,3	100	40	16,2	45
ST 60.15 – ST 80.24	16 B-1 (1" x 17,02 mm)	19	30000322	165,2	154,3	100	50	16,2	45

5.4 C-profile

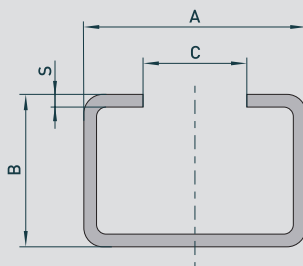

L = 3000

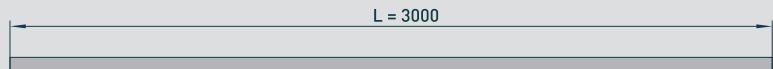

For ELEKTROMATEN	For Chain	Part no.	A	B	C	S
ST 9.15 / ST 9.24	12 B-1 (3/4" x 7/16")	40014217	29	24	13	1,5
ST 16.15 – ST 80.24	16 B-1 (1" x 17,02 mm)	40014218	48	29	20	2,5

5.5 Chain-tensioner

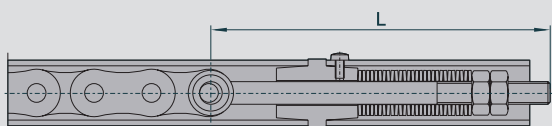

For ELEKTROMATEN	For Chain	Part no.	L
ST 9.15 / ST 9.24	12 B-1 (3/4" x 7/16")	30000143	100
ST 16.15 – ST 80.24	16 B-1 (1" x 17,02 mm)	30004265	150

