

ELEKTROMATEN® FS

Fire-door-drive

For driving: fire shutters which must close under their own weight in the case of fire

FS 15.20
FS 25.20
FS 50.20
FS 110.18

ELEKTROMATEN FS are special drives for fire shutters. The door shaft is driven by a chain-transmission. For rising loads a safety brake of the appropriate size must be fitted.

ELEKTROMATEN FS comprises of:

Spur gear, centrifugal brake, reversible universal brake¹⁾, integrated limit switches and electrical motor.

Spur gear

The spur gear allows the doors to close under their own weight in the case of a fire, even if there is a power failure.

Centrifugal brake ①

The centrifugal brake limits output speed in the case of a fire with power failure; the output speed in this case exceeds the normal operation output speed.

Patented universal brake¹⁾ with two switchable operation modes:

Installation mode ②

- The operation corresponds to that of a spring-loaded brake²⁾
- The door can be operated with a suitable door control like a standard roller shutter

Fire-protection mode ③

- The operation corresponds to that of a magnetic brake³⁾
- Operation as fire-door with VdS approval
- In the case of fire the universal brake opens and the door closes under the own weight.

Approvals and certificates

ELEKTROMATEN

MPA Materials Testing Institute of North-Rhine Westphalia (Germany)

Test report no. 120001461.60-01 (FS 15.20)

Test report no. 120001461.10-01 (FS 25.20, FS 50.20, FS 110.18)

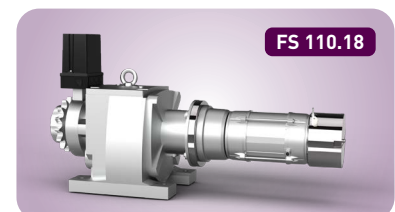
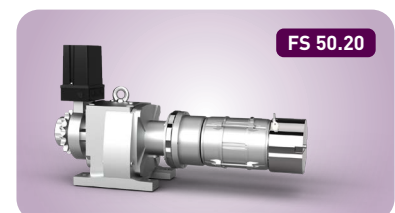
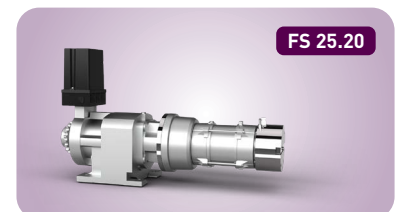
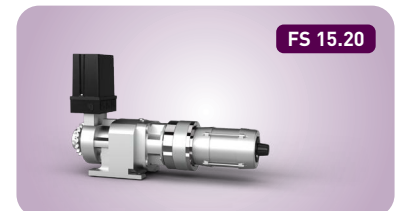

Centrifugal brake

- The centrifugal brake limits output speed in the case of a fire with power failure ①



Universal brake, reversible

- Installation mode ②
- Fire-protection mode ③

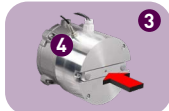

Switch sensor

- Optional electronic switch sensor ④
- Possibility of evaluating the operating status of the universal brake using a suitable control



Separate Safety Brake FG

- Prevention of doors falling back ⑤
- Suitable Safety Brakes for all types of ELEKTROMATEN FS can be found in Section 7.



Limit switches

Mechanical limit NES ⑥

- 2 operating, 2 emergency- and 2 auxiliary limit switches

Digital limit DES ⑦

- Absolute encoder, after a power failure, re-adjustment is not required

Connection cables

- Connection cables (for NES or DES) in different lengths for connection to a suitable door control⁴⁾
- NES connection cable: 7 m / 10 m / 15 m
- DES connection cable: 3 m / 5 m / 7 m / 13 m

1) Universal brake is not available for FS 15.20.
ELEKTROMATEN FS 15.20 only has a magnetic brake for fire-protection mode

2) Braking action when no voltage is applied

3) Braking action when voltage is applied

4) Door controls on request (not VdS-compliant)

1. Technical data

ELEKTROMATEN		FS 15.20		FS 25.20		FS 50.20		FS 110.18
Output torque	Nm	150		250		500		1100
Output speed	rpm	20		20		20		18
Output speed when triggered ¹⁾	rpm	23	36	23	30	23	30	23
Output shaft / hollow shaft (Ø)	mm	25		30		40		50
Restoring torque ²⁾	Nm	15		15		22		30
Max. holding torque ³⁾	Nm	150		250		500		1100
Motor power	kW	0,3		0,45		0,90		1,10
Supply voltage	V	3x400		3x400		3x400		3x400
Operating frequency	Hz	50		50		50		50
Operating current ⁴⁾	A	1,5		2,0		2,7		4,1
Max. cycles per hour ⁵⁾		14 (13,9)		12 (8,3)		11 (6,9)		10 (4,2)
Limit switch range ⁶⁾		20 (60)		20 (60)		20 (30, 60)		20 (30, 60)
Weight	kg	23		43		65		112
Part no. installation drawing (dxf, dwg)		50002118		50002119		50002120		50002121
Part no. ELEKTROMATEN		10005391	10005418	10005392	10005421	10005393	10005423	10005394

Generally applies: Degree of protection IP54, permissible temperature range -10 °C...+40 °C (+60 °C), operating sound pressure level SPL <70 dB(A)

1) See 2.4 · 2) See 2.7 · 3) Maximum torque that may act on the output shaft of the drive unit when the door is stationary · 4) The max. current in door drives can reach up to 4x the rated operating current for limited periods, see 2.5 · 5) One cycle consists of a complete opening and closing movement of the door. The value according to EN 60335-2-103 is given in brackets. If the limit switch range is not fully used, the number of possible cycles can be increased in relation to the reduced number of revolutions of the output shaft, see also 2.2 · 6) Maximum revolutions of the output shaft; optional limit switch ranges are listed in brackets (→ change in cycles per hour)

2. Notes

2.1 European directive

In accordance with the product standard EN 16034 Doors- and EN 12453 Safety in use of power operated doors-Requirements. Relevant local and national regulations also apply to doors used for fire-protection purposes.

2.2 Selection chart / Cycles per hour

The specified cycles per hour (see technical data) apply to even distribution and the limit switch range first mentioned. When using the temperature range +40 °C to +60 °C, the specified value must be halved. For other limit switch ranges, the values must be converted accordingly.

2.3 Gear self-braking / Brake

Drives without an electric brake have a self-sustaining worm gear and stop automatically.

On drives with an electric brake, stopping is achieved by the external brake. Brake inspection must always be carried out by qualified service engineers.

2.4 Safety brake

For rising loads a safety brake of the appropriate size must be fitted.

The admissible drive speeds for the safety brake may not be exceeded. The locking torque moment must not exceed the admissible loads on mechanical components such as e.g. fixings, shafts, keys etc.

2.5 Motor overload protection

Motor overload protection must be able to withstand 4x the operating motor current because the starting current of the drive unit can reach these levels for short periods.

2.6 Chain drive

It is not allowed to exceed the admissible loads on chains, shafts, keys and bearings. Observe the direction of the power input.

We recommend the use of drive sprockets with at least 15 teeth. The drive sprocket must not protrude beyond the end of the output-shaft.

The chain drive transmission is to be fitted with tensioning devices designed to prevent the chain riding up or disengaging.

2.7 Restoring torque

The restoring torque values indicated (See item - 1. Technical data) must be applied to the door assembly in its open position in order to ensure that the door can be closed in the case of fire with power failure.

3. Selection chart

ELEKTROMATEN	Tube	Transmission		Transmission		Transmission		Transmission		
	EN 10220	1:2		1:3		1:3,8		1:4,5		
	[mm]	F [N]	v _a [cm/s]	F [N]	v _a [cm/s]	F [N]	v _a [cm/s]	F [N]	v _a [cm/s]	
FS 15.20	133,0 x 4,0	3137	8,0	4705	5,3	5961	4,2	7059	3,6	
	159,0 x 4,5	2681	9,4	4022	6,2	5095	4,9	6033	4,2	
	177,8 x 5,0	2426	10,4	3640	6,9	4611	5,5	5460	4,6	
FS 25.20	133,0 x 4,0	5229	8,0	7843	5,3	9935	4,2	11765	3,6	
	159,0 x 4,5	4469	9,4	6704	6,2	8492	4,9	10056	4,2	
	177,8 x 5,0	4044	10,4	6067	6,9	7685	5,5	9100	4,6	
	193,7 x 5,4	3744	11,2	5615	7,5	7113	5,9	8423	5,0	
	219,1 x 5,9	3346	12,5	5019	8,3	6357	6,6	7528	5,6	
FS 50.20	159,0 x 4,5	8939	9,4	13408	6,2	16983	4,9	20112	4,2	
	177,8 x 5,0	8089	10,4	12133	6,9	15369	5,5	18200	4,6	
	193,7 x 5,4	7487	11,2	11231	7,5	14226	5,9	16846	5,0	
	219,1 x 5,9	6692	12,5	10038	8,3	12714	6,6	15056	5,6	
	244,5 x 6,3	6049	13,8	9074	9,2	11493	7,3	13611	6,2	
	273,0 x 6,3	5461	15,3	8191	10,2	10375	8,1	12287	6,8	
	298,5 x 7,1	5024	16,7	7535	11,1	9545	8,8	11303	7,4	
	323,9 x 7,1	4653	18,0	6979	12,0	8840	9,5	10468	8,0	
	FS 110.18	177,8 x 5,0	17796	9,3	26694	6,2	33812	4,9	40040	4,1
		193,7 x 5,4	16472	10,1	24708	6,7	31296	5,3	37061	4,5
219,1 x 5,9		14722	11,3	22083	7,5	27972	5,9	33124	5,0	
244,5 x 6,3		13308	12,5	19962	8,3	25285	6,6	29943	5,5	
273,0 x 6,3		12014	13,8	18020	9,2	22826	7,3	27031	6,1	
298,5 x 7,1		11052	15,0	16578	10,0	20998	7,9	24867	6,7	
	323,9 x 7,1	10236	16,2	15353	10,8	19448	8,5	23030	7,2	

■ F = Lift [N]

■ v_a = Initial speed [cm/s]

■ Includes 20 % friction (profile thickness 20 mm)

4. Dimensions

From 2022, ELEKTROMATEN FS will have new connecting dimensions. Intermediate plates (6) available as an option allow the installation of the new drive units on

doors with the old connecting dimensions. When using the intermediate plates, the centre distance (B) between the output shaft and the door shaft increases slightly.

4.1 FS 15.20

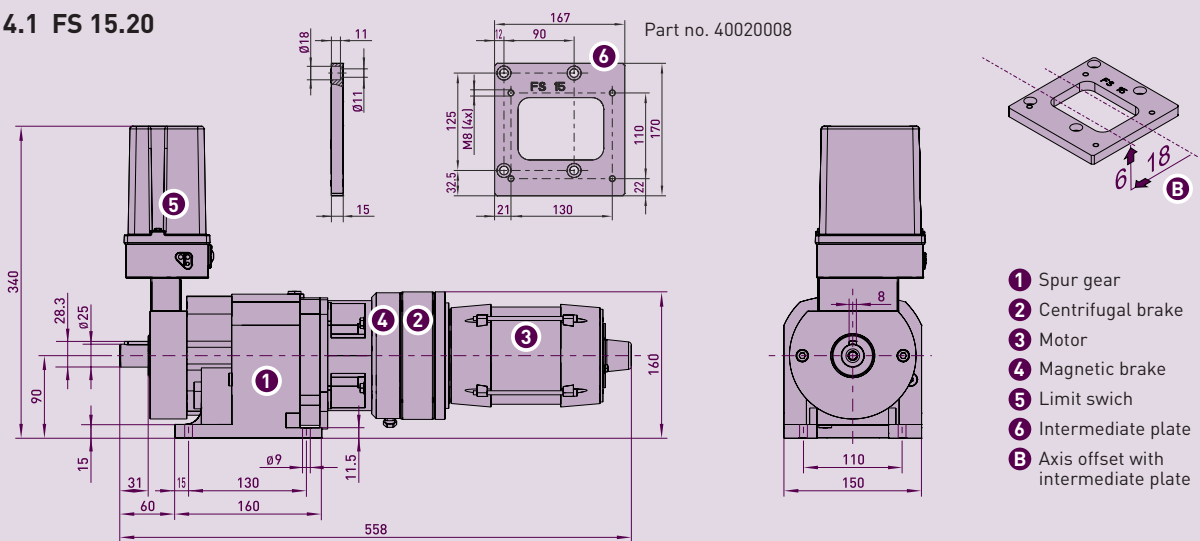

■ Permitted installation: Horizontal (as shown)



4.2 FS 25.20

Part no. 40020009

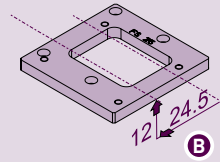
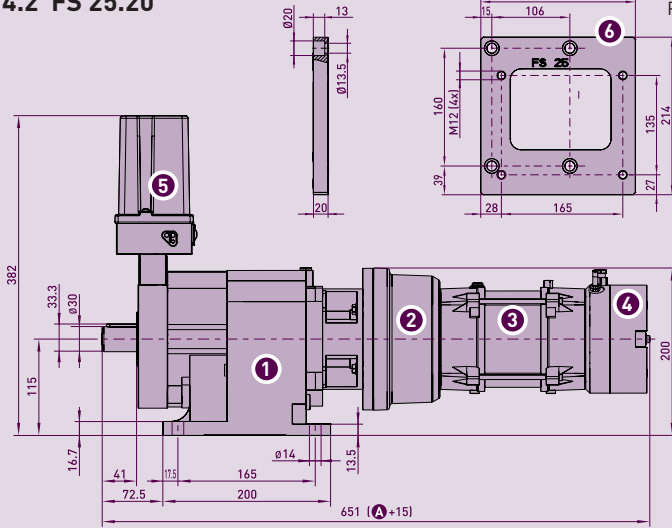

- 1 Spur gear
- 2 Centrifugal brake
- 3 Motor
- 4 Universal brake
- 5 Limit switch
- 6 Intermediate plate
- A Installation mode
- B Axis offset with intermediate plate

■ Permitted installation: Horizontal (as shown)

4.3 FS 50.20

Part no. 40020010

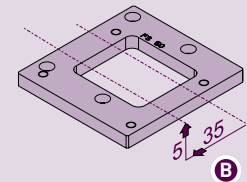
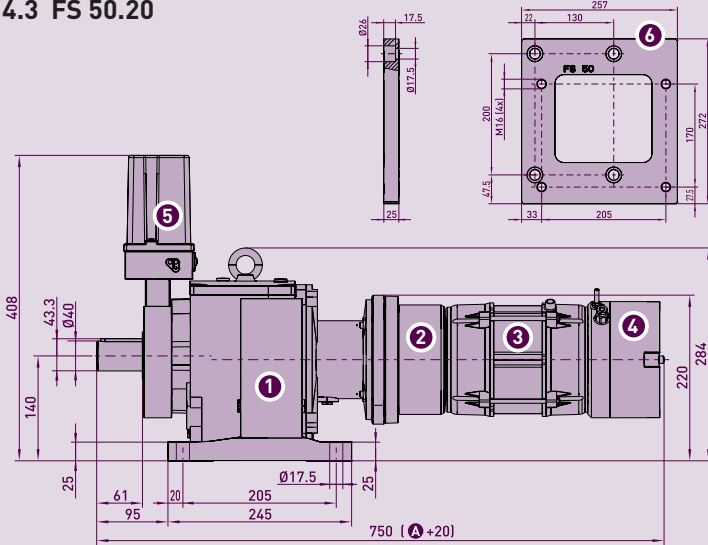

- 1 Spur gear
- 2 Centrifugal brake
- 3 Motor
- 4 Universal brake
- 5 Limit switch
- 6 Intermediate plate
- A Installation mode
- B Axis offset with intermediate plate

■ Permitted installation: Horizontal (as shown)

4.4 FS 110.18

Part no. 40020011

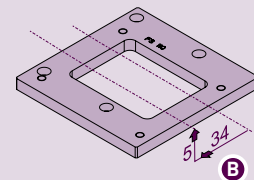
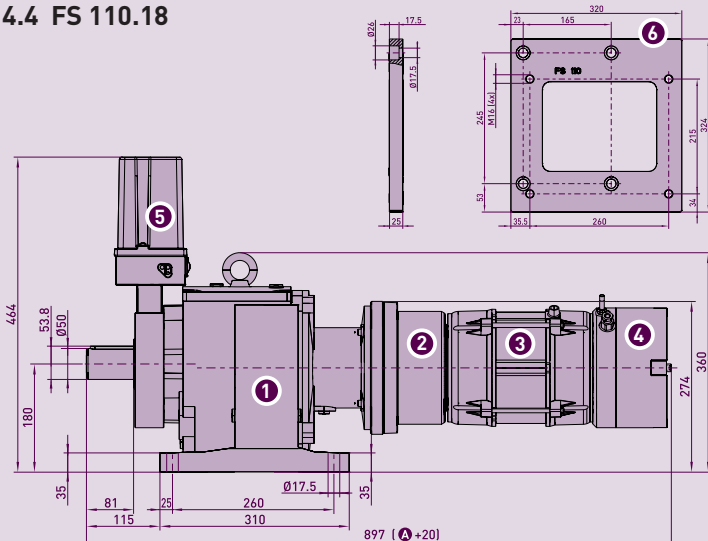

- 1 Spur gear
- 2 Centrifugal brake
- 3 Motor
- 4 Universal brake
- 5 Limit switch
- 6 Intermediate plate
- A Installation mode
- B Axis offset with intermediate plate

■ Permitted installation: Horizontal (as shown)

Accessories

5.1 Sprockets

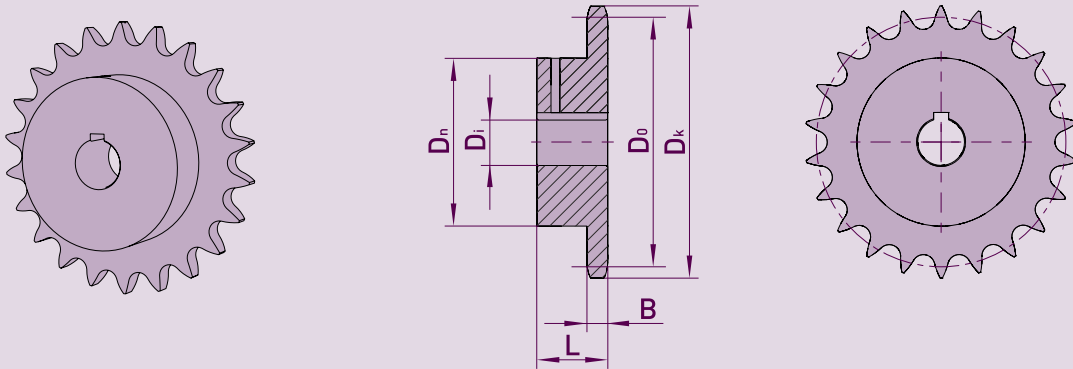

For ELEKTROMATEN	Designation	Teeth	Part no.	D_k	D_0	D_n	D_i	B	L
FS 15	12 B-1 (3/4" x 7/16")	15	30000211	99,8	91,6	70	25	11,1	35
		19	30000212	124,2	115,8	80	25	11,1	35
FS 25	12 B-1 (3/4" x 7/16")	15	30000538	99,8	91,6	70	30	11,1	35
		19	30000310	124,2	115,8	80	30	11,1	35
FS 50	16 B-1 (1" x 17,02 mm)	15	30000171	133,0	122,2	92	40	16,2	40
		19	30000321	165,2	154,3	100	40	16,2	45
FS 110	20 B-1 (1 1/4" x 3/4")	15	30002900	167,9	152,7	118	50	18,5	45

■ Additional sprockets in Section 9

5.2 Roller chains

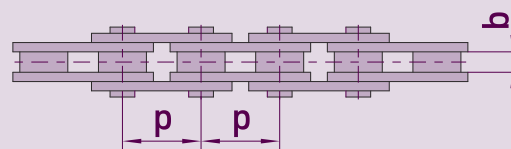
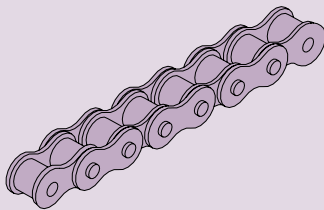

Designation	p x b [inch]	p x b [mm]	Ultimate load of chain DIN 8187 [N]	Number of teeth's	Max. M_{ab} [Nm]	Description	Part no.
12 B-1	3/4" x 7/16"	19,05 x 11,68	29.000	15	220	2,0 m	40003030
				19	280	5,0 m	40013909
						Link	40000615
16 B-1	1" x 17,02 mm	25,4 x 17,02	60.000	15	610	2,5 m	40005049
				19	770	5,0 m	40013910
						Link	40000617
20 B-1	1 1/4" x 3/4"	31,75 x 19,56	95.000	15	1200	3,0 m	40014878
				19	1520	5,0 m	40017784
						Link	40001111

■ For chain and sprockets, the maximum permitted torque M_{ab} on ELEKTROMATEN is as shown in the table (safety factor 6x the breaking strain)

