

Fire Shutter Door Drives Actuator Release



Introduction

This instruction book is suitable for use with the following GfA fire shutter door drive units.

DLA250W
DLA500W
DLA600
DLA800
DLA1000

Please read the following instructions before proceeding with the installation of your drive unit.

General safety information

Safety at Work

It is the responsibility of the owner, installer and user to ensure that the installation of the equipment and the way in which it is operated and maintained complies with the requirements of the Health & Safety at Work Act in the United Kingdom and other applicable legislation, regulations and codes of practice in the UK or elsewhere.

Only qualified personnel should install this equipment, after first reading and understanding the information in this publication. The installation instructions should be adhered to.

Inspection

Immediately after unpacking the equipment, please inspect as follows:

Check the rating plate corresponds to the order specification.

Inspect the equipment to determine whether it has been damaged in transit.

Look for loose components and damage to any part of the motor, covers, mounting brackets or other components.

Product Enquiries

If at any time you have a difficulty or a question regarding the equipment, please contact the supplier at the address on the back cover of this manual.

The following information will be required.

- a) Equipment type.
- b) Age of equipment.
- c) The nature of the problem - for instance, the location and extent of damage, the point which is unclear or the circumstances under which a malfunction occurred.

Documentation

Every effort has been made by supplier to ensure that this document accurately and completely represents the equipment at the time of going to press. Information with respect to installation is necessarily generalised, and the supplier accepts no liability for contingencies over which he has no control in respect of the selection, installation and/or operation of equipment.

In line with our policy of continuous improvement, the contents of this document are subject to change without prior notice.

Mounting the drive

NOTE !

Before commissioning the drive, i.e. setting mechanical limits, the actuator must be energised, failure to do so, will result in the shutter dropping with possible injury to personnel.

The DLA range of drives with DK kit are supplied with a mounting plate which is designed to be used in conjunction with a special bearing housing. The mounting plate and bearing housing will already be mounted onto the shutter cheek plate.

Fit the safety brake to roller. Ensure the direction arrow on the brake is pointing in the "shutter" down direction. Install the roller with the safety brake sitting on its bracket and with the sprocket end located in the bearing housing.

Lift and swing the bearing retaining pin across the top of the bearing and ensure it is clipped home securely.

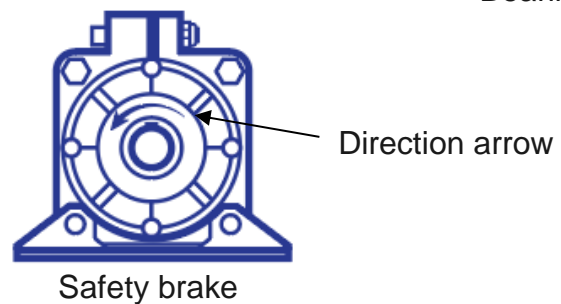
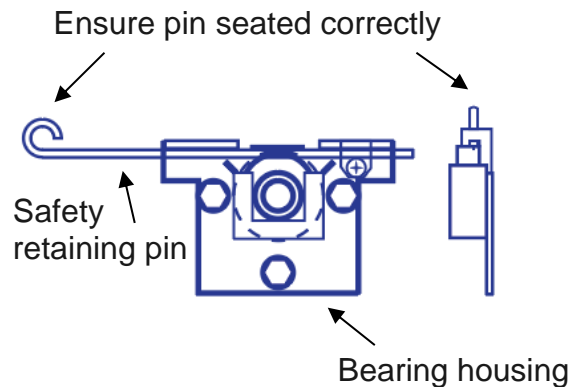

NOTE ! This is a safety critical item.

If using GfA's DK kit, fit the drive unit onto the mounting plate with the three M10 bolts and spacers provided and tighten. Fit the roller chain from the drive to the barrel. Ensure the necessary bolts are only finger tight whilst tensioning the chain. Once adjusted fully tighten up all mounting bolts and secure the drive unit to the mounting plate. Secure the mounting plate to the building structure to ensure that no movement is observed when the drive is under load.

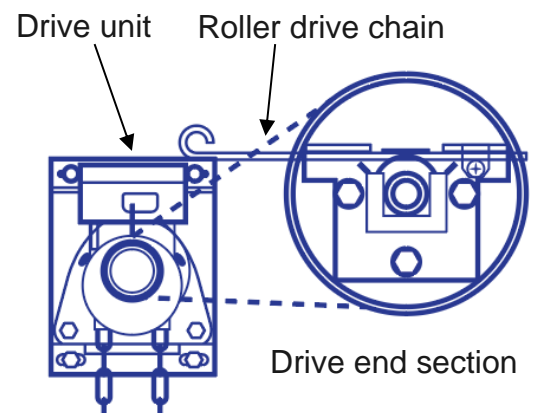

Rotate the drive using the hand chain and check throughout a complete revolution of the barrel, that the chain tightness remains within the recommended figures.

NOTE ! Do not remove the drive sprocket without first referring to the supplier.

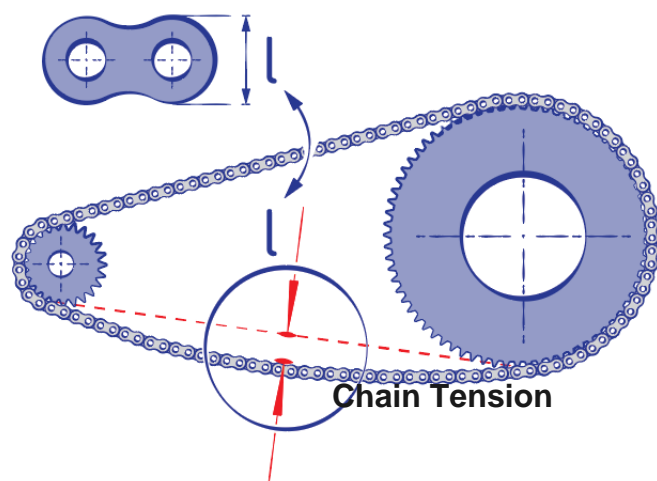

Release mechanisms

Each drive unit has fitted to it a 'Fire' release mechanism. Please check your drive has the correct one for the installation and then refer to the relevant instruction:

1. Level 1 fire - Fusible link.

The fusible link should be mounted in a suitable position so as the Bowden cable has a free and unrestricted operating path. The number and severity of turns in the cable should be kept to a minimum in order to obtain optimum performance. The minimum radius should be no less than 100mm.

It should be securely mounted either above the door canopy or onto the building structure. The cable should be adjusted with the relevant adjusters either longer or shorter to obtain the correct operation once the path has been determined.

It should be operated several times to verify the operation is satisfactory.

- The operation should be checked both electrically & mechanically to determine that in both modes the cable is correct. Failure to do so may lead to operational failure. If the motor has a separate cover this should not impede the operation of the fusible link. It should also be accessible for routine testing as required.

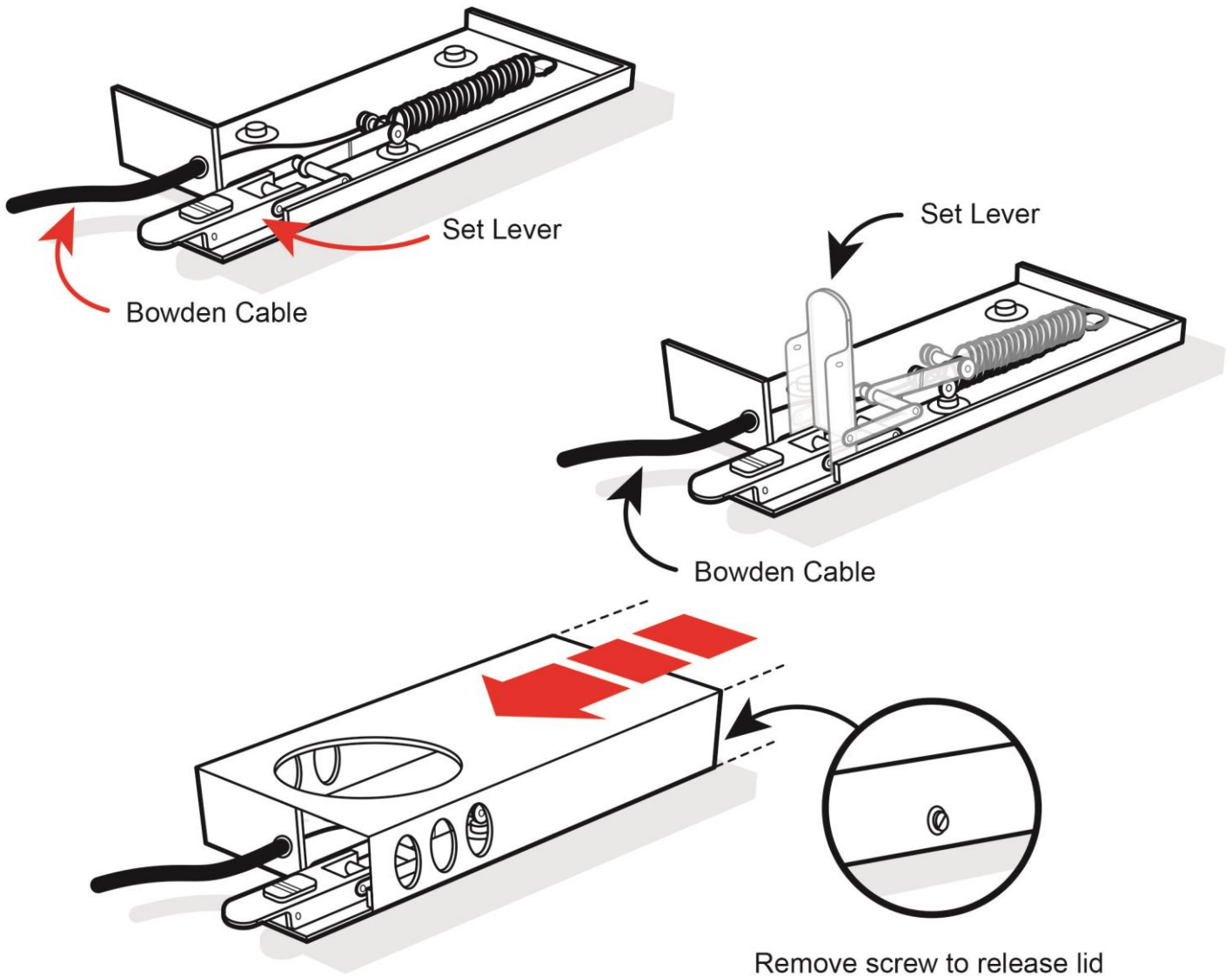

Release mechanisms

2. Level 2 fire – 24V dc Energised to hold Actuator

When the Actuator is de-energised it will release the drive brake and the door will close by controlled gravity descent (fail-safe).

During installation and commissioning the actuator must be energised to prevent the motor from turning and the door closing.

The Shutter is reset by re-energising the Actuator and giving the shutter an open command.

3. Level 3 fire – 24V dc Energised to hold Actuator and Fusible Link

Combines the benefits of the energised-to-hold Actuator and the Fusible Link.

Manual operation

The DLA models are supplied with a single hand chain manual operator suitable for horizontal installation (chain is operated vertically).

NOTE !

Under no circumstances should the manual operator be engaged whilst the drive unit is being electrically operated. To do so will result in possible injury to personnel and / or damage to the manual operator system.

The manual operator has a ratchet mechanism that allows operation in one direction only. During installation the operating direction should be set so the shutter can be opened from the manual operator (The brake should be released to close the shutter).

The snatch plate should be positioned against the motor body with the manual operating chain passing through the middle.

To open the shutter with the manual operator proceed as follows:

1. Isolate the drive unit from the mains supply. (24vdc needs to be kept on terminals 17-18 from the batteries to ensure movement from the hand chain mechanism).
2. With the door stationary, pull the hand chain.

If operation is blocked then pull the chain in the opposite direction. This should allow opening of the shutter.

3. Releasing the chain automatically allows normal electrical operation.

Do not snatch the chain during manual operation as this may damage either the chain or the operator mechanism.

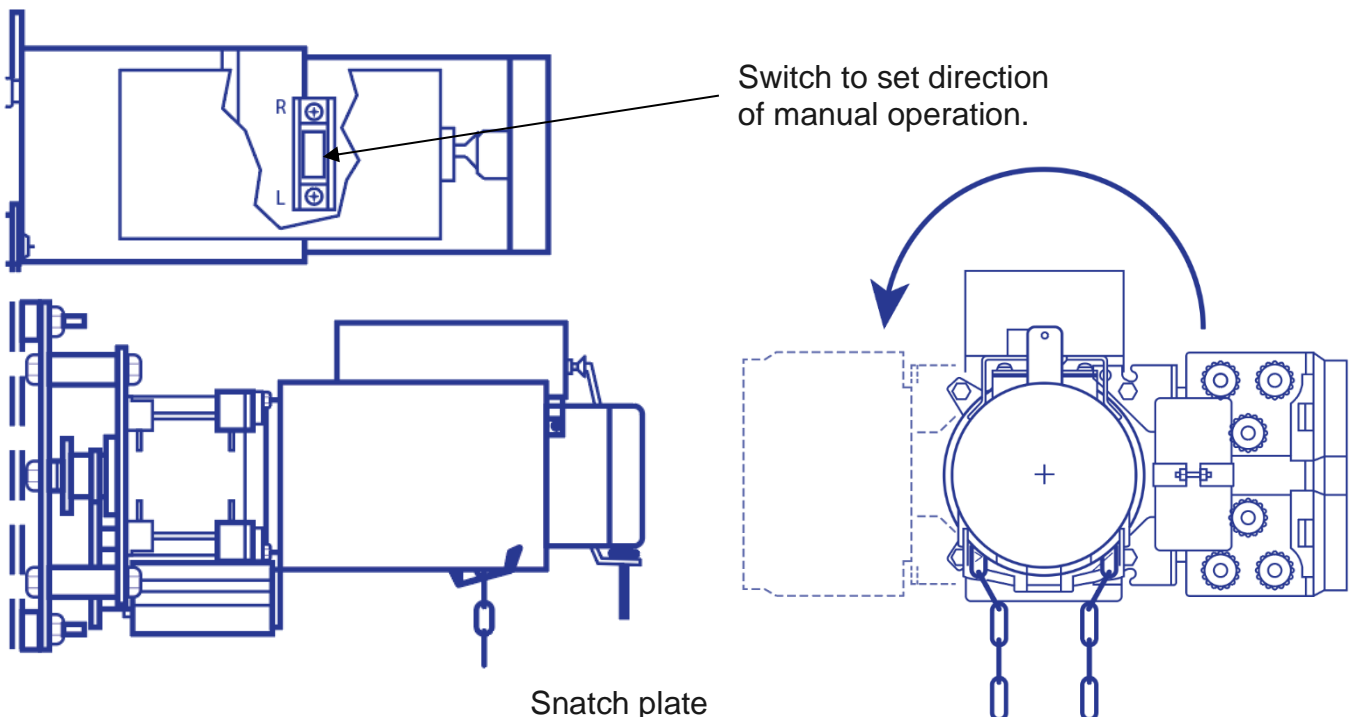

Three phase starter

Connect a 3 phase supply to terminals L1, L2, L3, Neutral to X3 and Earth to PE.

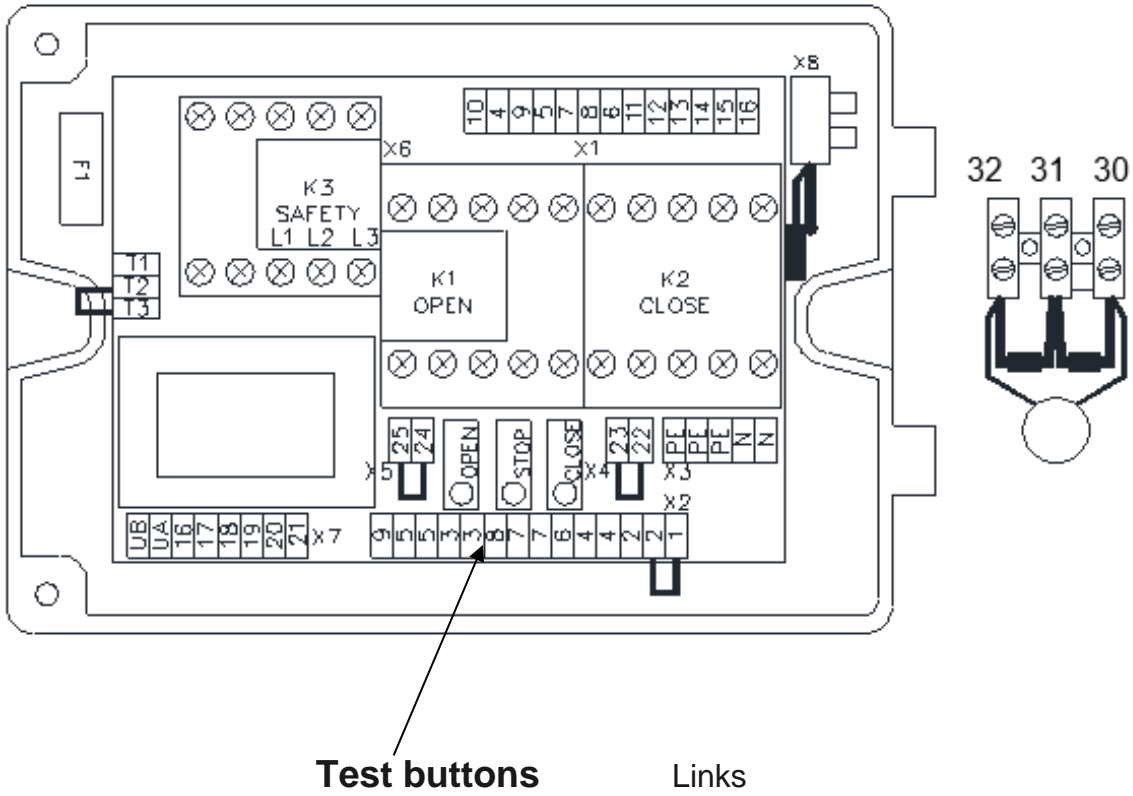

Single phase starter

Connect a single phase supply to terminals L + N (K1) + PE Earth.

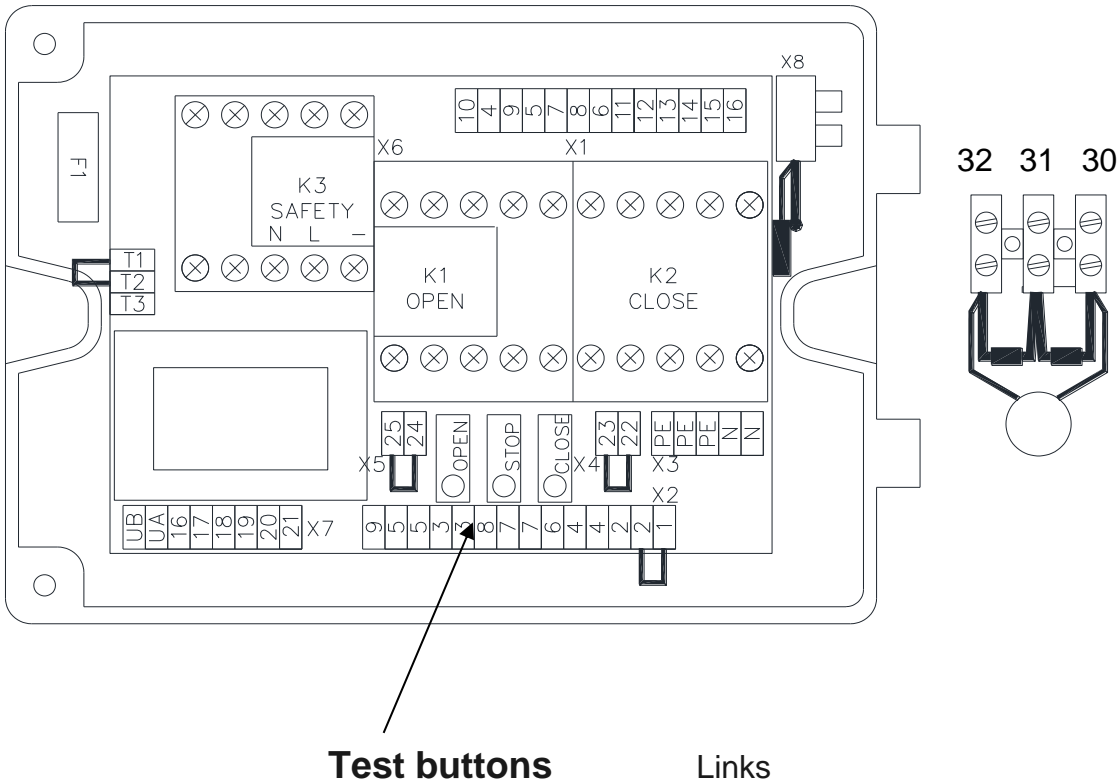

1 ~ drive with built on starter. 24V dc Alarm Actuator.

Drawing reference: GDE61251

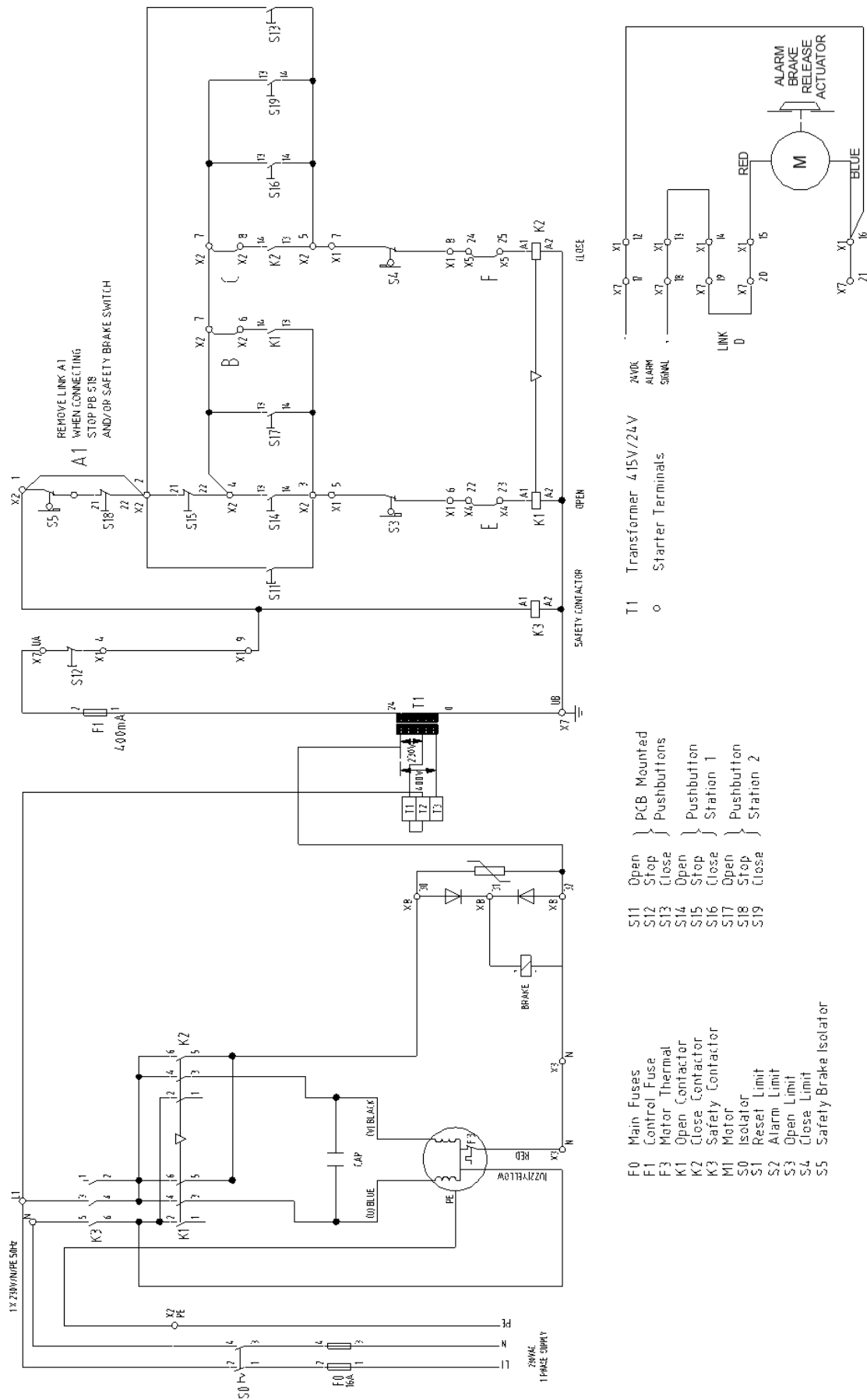

- F0 Main Fuses
- F1 Control Fuse
- F3 Motor Thermal
- K1 Open Contactor
- K2 Close Contactor
- K3 Safety Contactor
- M1 Motor
- S0 Isolator
- S1 Reset Limit
- S2 Alarm Limit
- S3 Open Limit
- S4 Close Limit
- S5 Safety Brake Isolator
- S11 Open
- S12 Stop
- S13 Close
- S14 Open
- S15 Stop
- S16 Close
- S17 Open
- S18 Stop
- S19 Close
- PCB Mounted
- Pushbuttons
- Pushbutton Station 1
- Pushbutton Station 2
- T1 Transformer 415V/24V
- Starter Terminals

3 ~ drive with built on starter. 24V dc Alarm Actuator.

Drawing reference: GDE61254

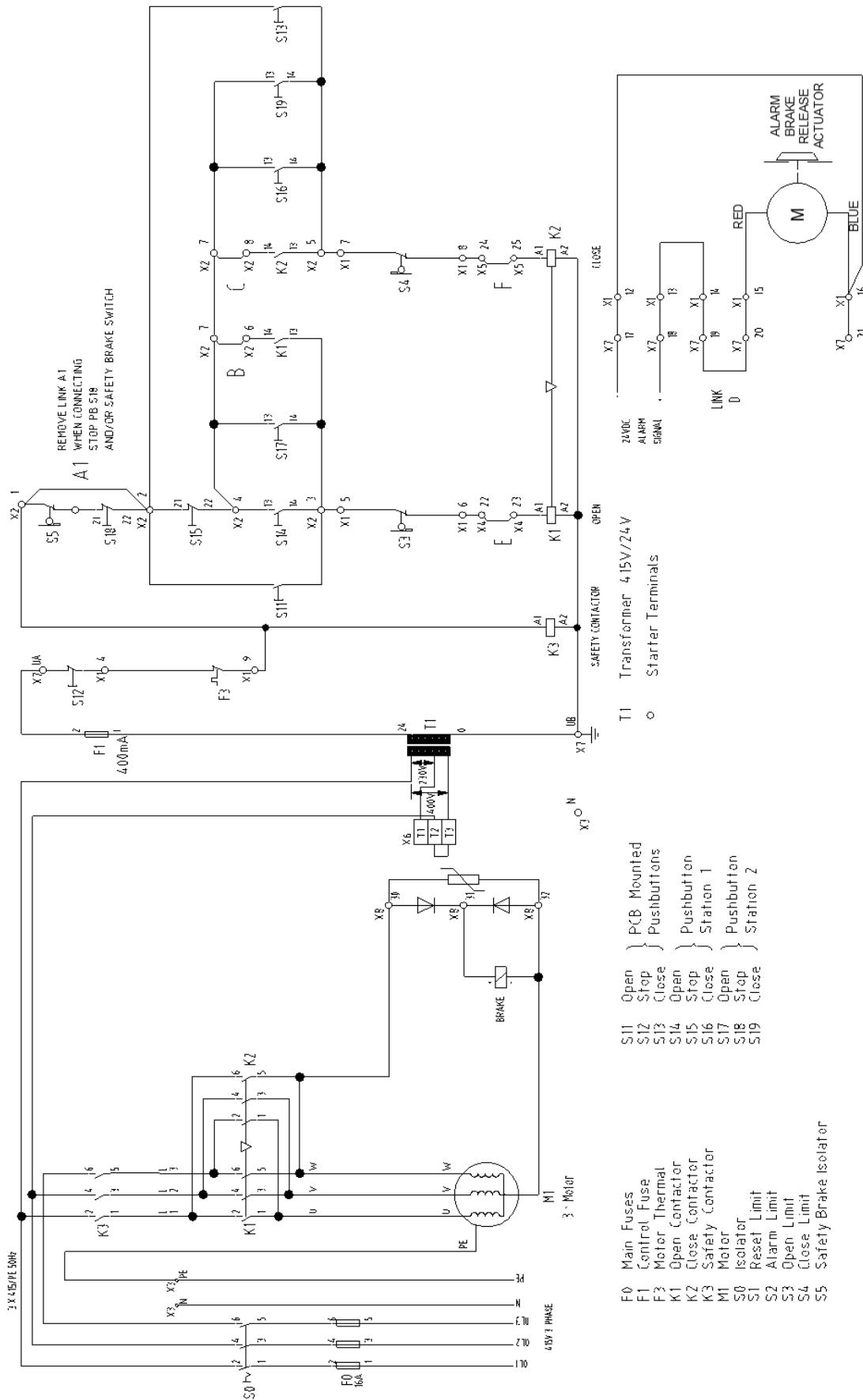

Note: To reverse motor direction exchange 2 phase wires

Wiring an FCP03 Fire Door Control

N.B. Refer to the FCP03 instructions for push button connections and a full description of all settings.

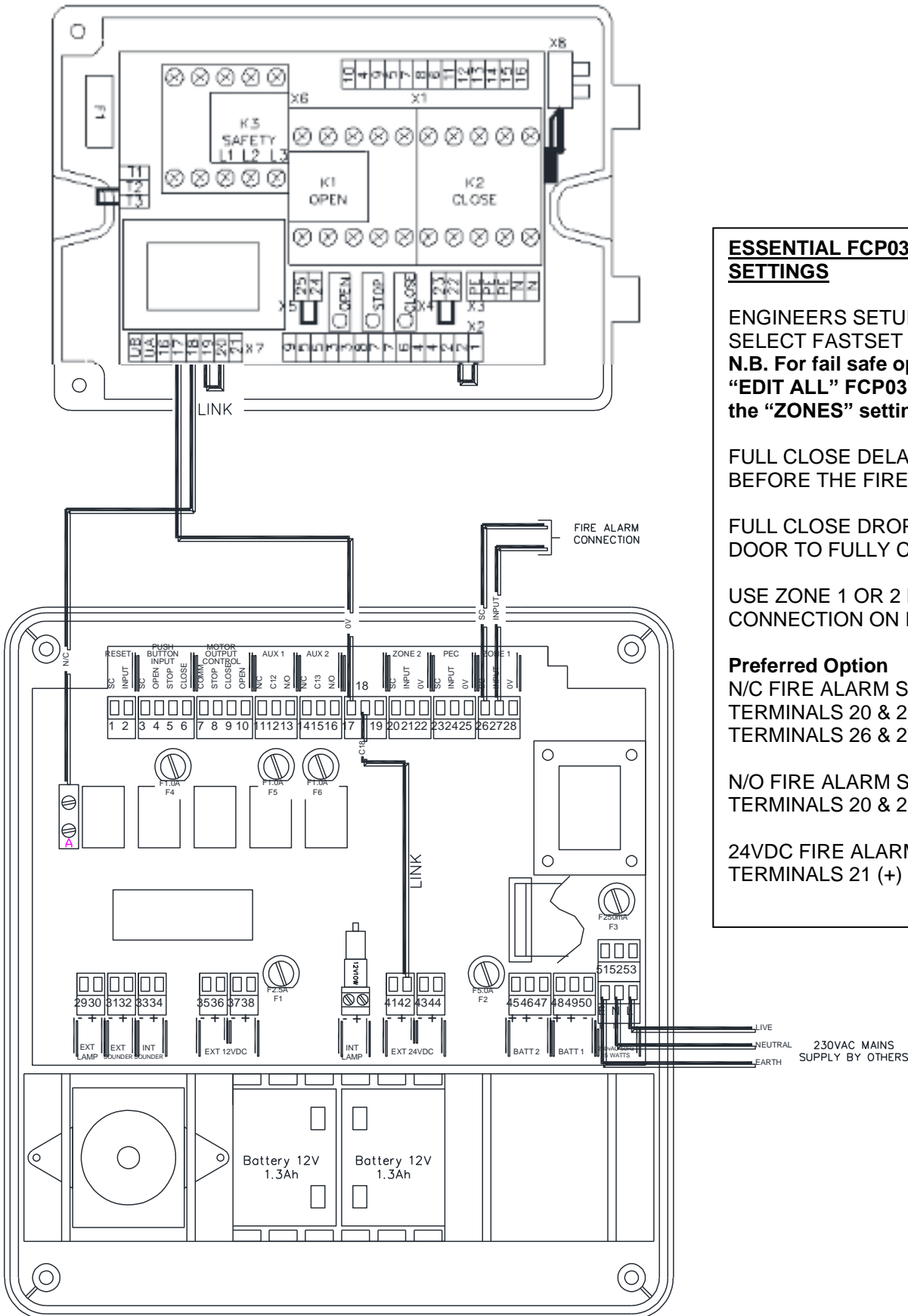

ESSENTIAL FCP03 PARAMETER SETTINGS

ENGINEERS SETUP
 SELECT FASTSET 1 or 2
N.B. For fail safe operation using the "EDIT ALL" FCP03 function change the "ZONES" setting to NC alarm.

FULL CLOSE DELAY - TIME DELAY BEFORE THE FIRE DOOR CLOSES

FULL CLOSE DROP - TIME FOR THE DOOR TO FULLY CLOSE

USE ZONE 1 OR 2 FOR FIRE ALARM CONNECTION ON FULL DROP.

Preferred Option
 N/C FIRE ALARM SIGNAL - TERMINALS 20 & 21 WITH LINK IN TERMINALS 26 & 27

N/O FIRE ALARM SIGNAL - TERMINALS 20 & 21

24VDC FIRE ALARM SIGNAL - TERMINALS 21 (+) & 22 (-)

Wiring a 3pb Station without FCP03

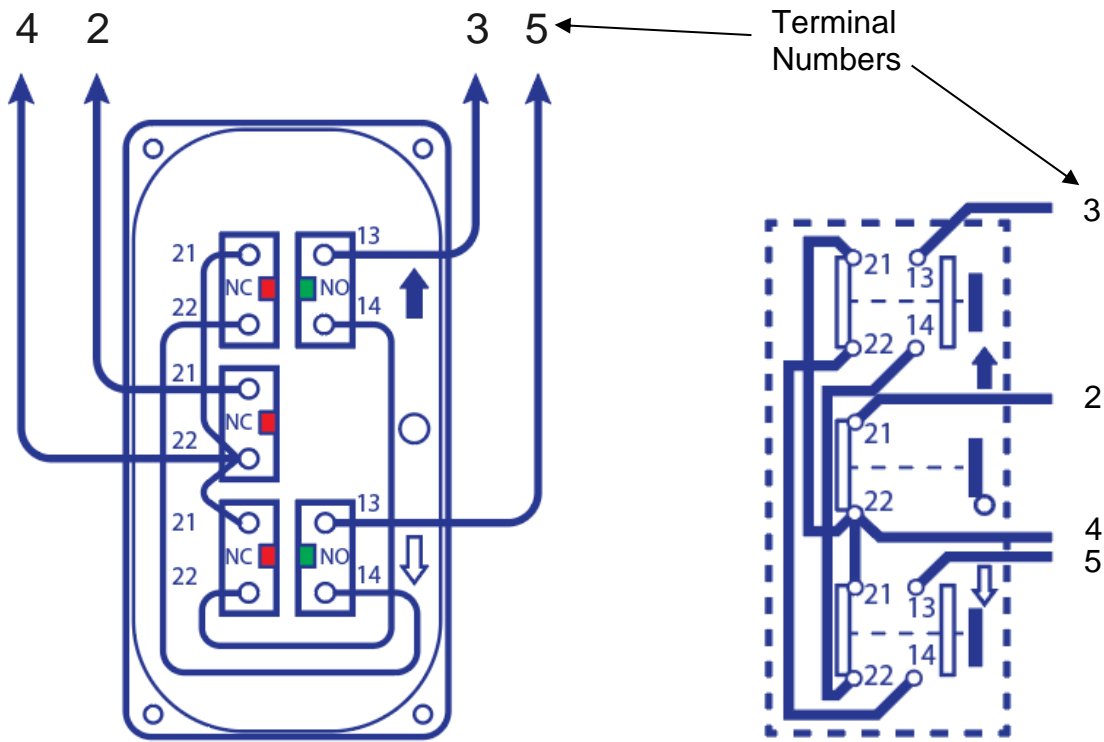

Direct wiring of a 24Vdc alarm signal (normally energised, de-energised in alarm) without FCP03

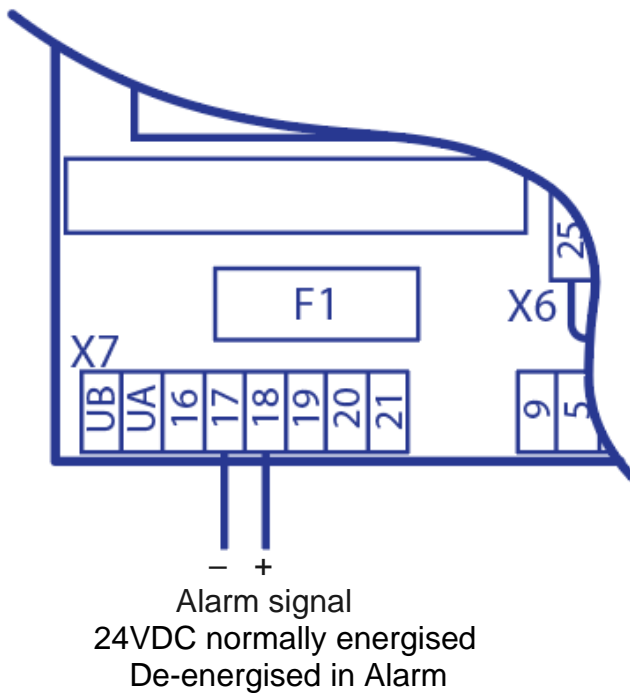

Additional 3pb Station without FCP03

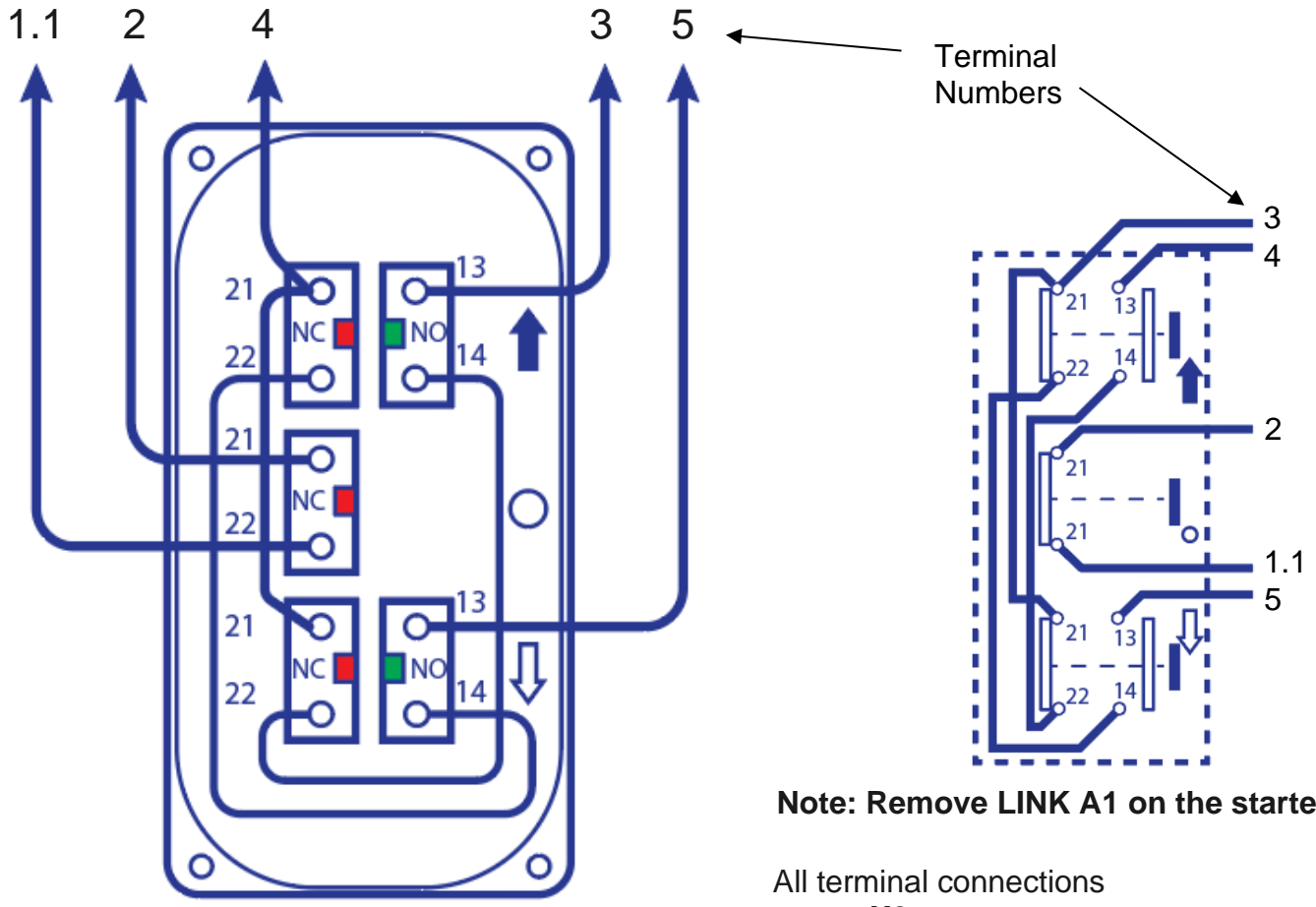

Note: Remove LINK A1 on the starter

All terminal connections are on X2 connector

Wiring a 2pb station

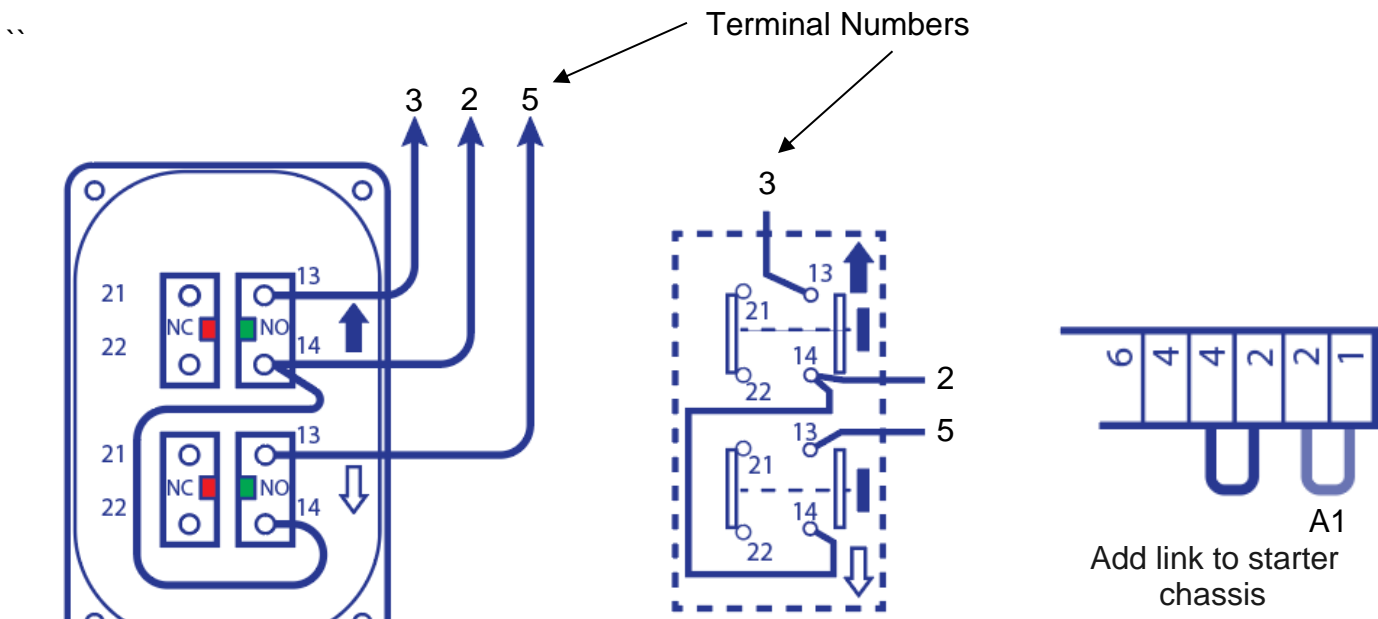

Operation will be deadman

Wiring a 3pb Station with Key switch (JAPZ4-1R) without FCP03

Keyswitch disables all operation of the fire shutter.

Terminal Numbers

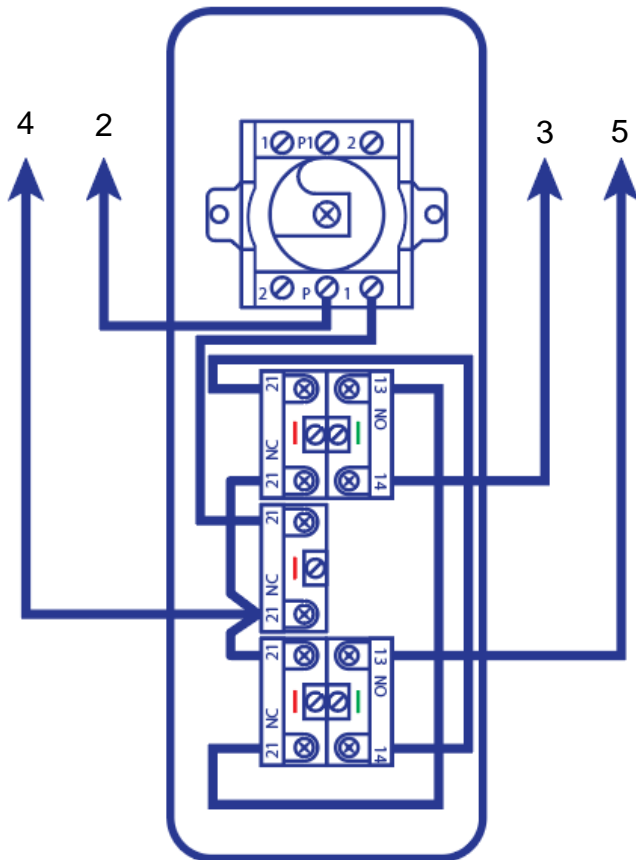

N.B. For Hold-to-run (deadman) operation do not connect to terminal number 4

Wiring a key switch (JSAPZ1-2T) without FCP03

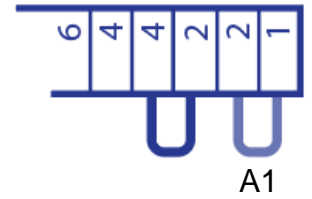
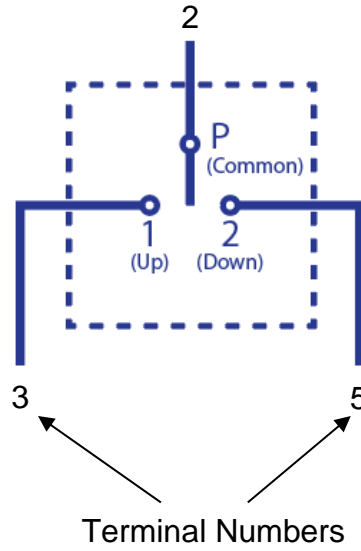
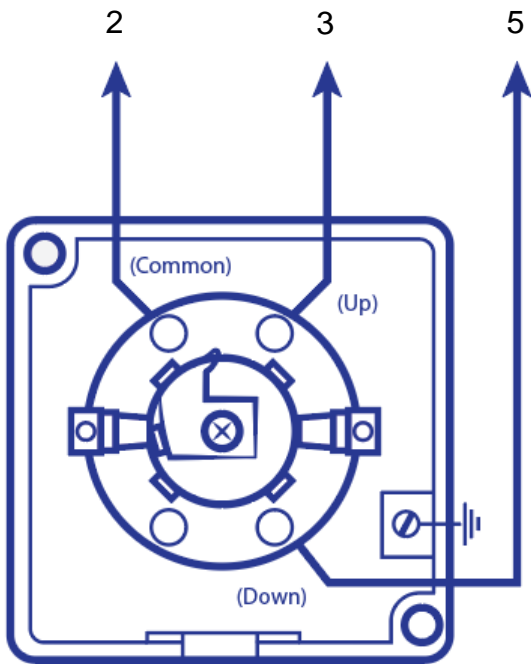

Add link to starter Chassis

Operation will be deadman

Setting the limits

Models DLA250W

These drives are fitted with two instant set limit switches.

To set the limit position

1. First identify your drive handing from the detail in fig 1. Then whilst setting the limit levers refer to the “right type” or “left type” instructions as required.

Note: All drive units are wired for Right Type. If your installation is left type, exchange the red and blue, limit wires on the starter pcb as shown and reverse motor direction.

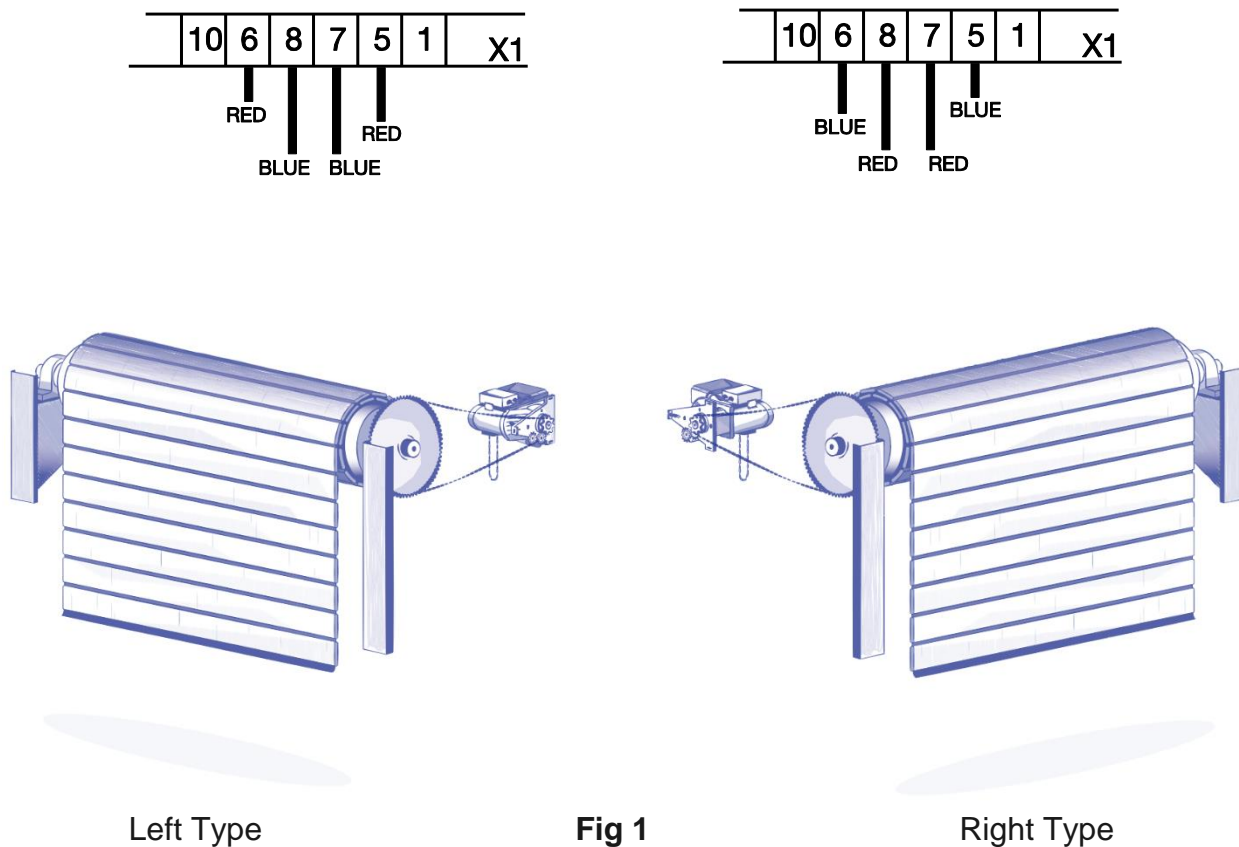

2. Move both the limit setting levers to the “before setting” position. See fig 2.
Note ! With the levers in this position the drive does not have any limit stops.

Setting the limits

Models DLA250W

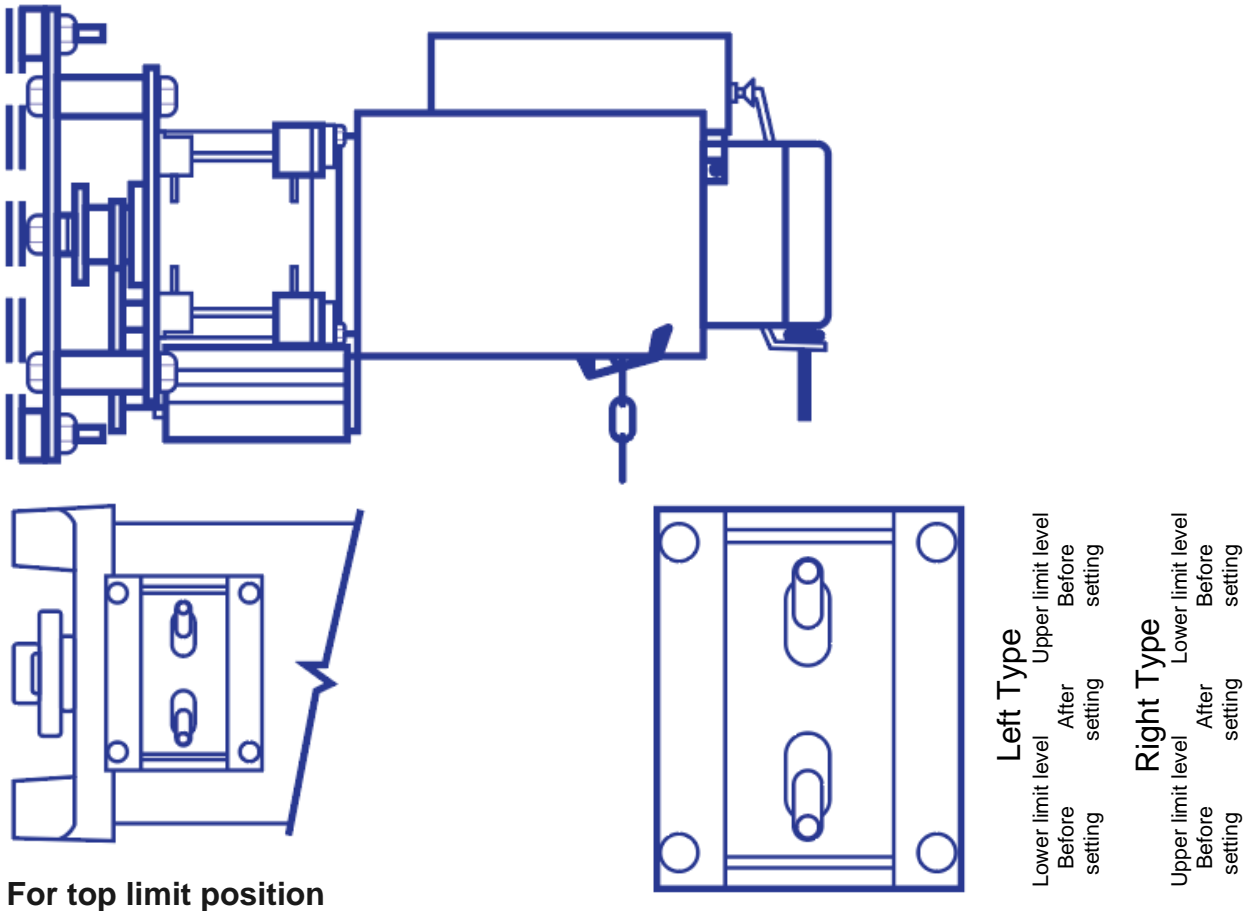

For top limit position

3. Carefully operate the shutter to the position intended to be the upper limit. Select the correct lever (as identified in first stage of setting) and move the upper limit lever to the “after setting” position.
4. Drive the motor to close the shutter about 1m. Re-open the shutter and check the upper limit.

If the shutter does not stop as required, move the shutter to the required position then move the limit lever to the “before setting” position and back to the “after setting” position.

For bottom limit position

5. Carefully operate the shutter to the position intended to be the lower limit. Select the correct lever (as identified in first stage of setting) and move the lower limit lever to the “after setting” position.
6. Drive the motor to open the shutter about 1m. Close the shutter and check the lower limit. If the shutter does not stop as required, move the shutter to the required position then move the limit lever to the “before setting” position and back to the “after setting” position.
7. Check both the upper and lower limit positions.

Setting the limits

Models DLA500W, DLA600, DLA800 and DLA1000

This drive is fitted with two cam/thread limit switches, rated at 230V, 3A.

To set the limit position

1. First identify your drive handing from the detail in fig 3.
2. Loosen off the two cam retaining screws to stop the cams from moving along the threaded shaft. **Note! With the cam retaining screws loose the drive does not have any limit stops.**

Note: All drive units are wired for right type. If your installation is left type, exchange the red and blue, limit wires on the starter pcb as shown and reverse motor direction.

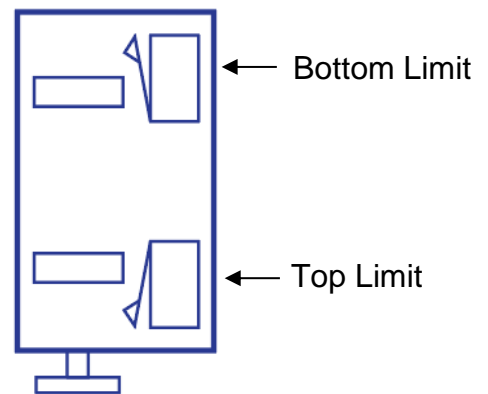
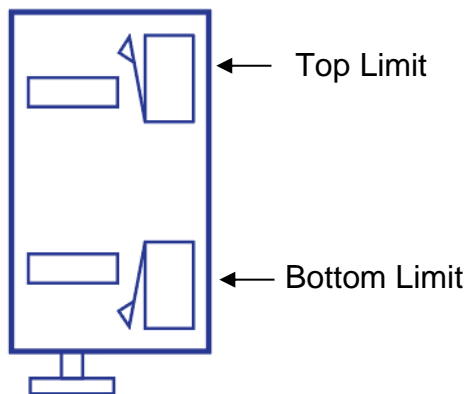
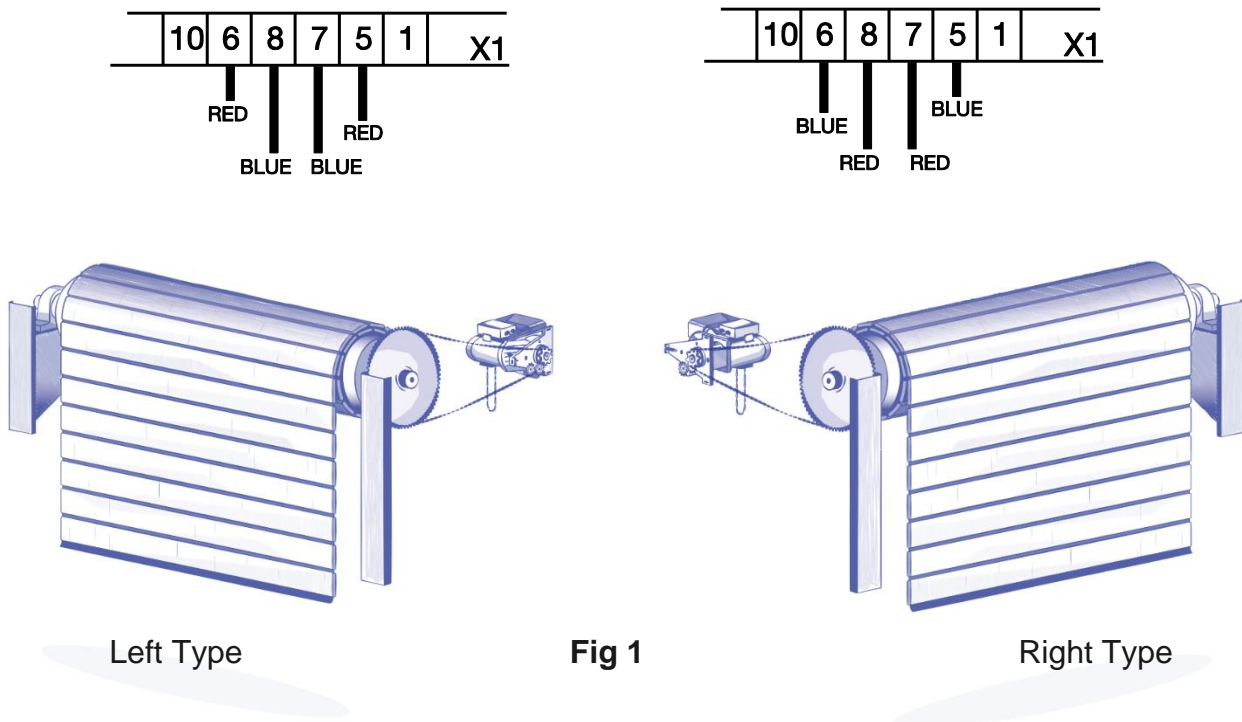

Setting the limits

Models DLA500W, DLA600, DLA800 and DLA1000

For top limit position

3. Carefully operate the shutter to the position intended to be the upper limit. Select the correct brass limit adjuster (as identified in first stage of setting) and move the limit cam up the threaded shaft until it operates the limit.
4. Tighten the cam retaining screw. Drive the shutter closed by 1m. Open the shutter and check the upper limit.

For bottom limit position

5. Carefully operate the shutter to the position intended to be the lower limit. Select the correct brass limit adjuster (as identified in first stage of setting) and move the limit cam up the threaded shaft until it operates the limit.
6. Tighten the cam retaining screw. Drive the shutter open by 1m. Close the shutter and check the lower limit.
7. Check both the upper and lower limit positions.
8. Points to check.
 - a. Ensure that both cams are not on top of the limits at the same time.
 - b. Ensure, during travel the cam slides do not contact each other.
 - c. Ensure the cams do not contact the main limit housing during travel.

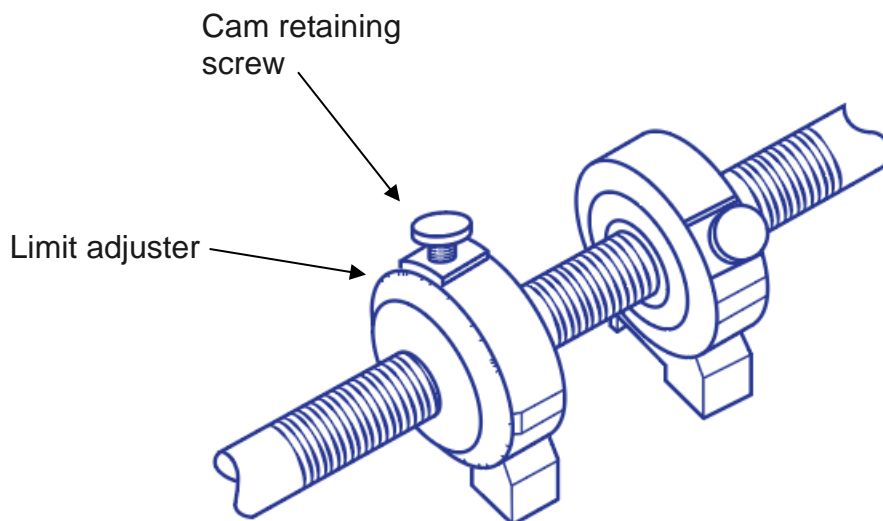

Blank

Declaration of Incorporation

In accordance with the Supply of Machinery (Safety)
Regulations 2008 for partly completed machinery
Appendix II Part B



GfA ELEKTROMATEN UK Ltd

GfA UK Ltd, Tournament Fields Business Park,
Agnocourt Road, Warwick, CV34 6XZ

Declaration of Conformity

within the meaning of EMC Regulations 2016,
within the meaning of Electrical Equipment (Safety) Regulations 2016

We

GfA ELEKTROMATEN UK Ltd

Declare under our sole responsibility that the product(s) specified below conform to the stated UK legislation and is only intended for installation in a door system. This product must only be put into operation once the complete machine/system in which it has been installed complies with the provisions of the above-mentioned directives.

DLA150W, DLA250W, DLA500W, DLA600, DLA800, DLA1000

Harmonised Standards applied:

- | | | |
|-----------------------|---|---|
| BS EN 60335-1:2012 | - | Household and similar electrical appliances - Safety – Part 1: General requirements. |
| BS EN 60335-2-97:2008 | - | Particular requirements for drives for rolling shutters, awnings, blinds and similar equipment. |
| BS EN 61000-6-2:2005 | - | Electromagnetic compatibility (EMC) - Part 6-2 Generic standards – Immunity for industrial environments |
| BS EN 61000-6-3:2007 | - | Electromagnetic compatibility (EMC) - Part 6-3 Generic standards – Emission standard for residential, commercial and light-industrial environments |

We undertake to transmit, in response to a reasoned request by the appropriate regulatory authorities, relevant information on the partly completed machinery identified above.

Authorised representative for the compilation of the technical documentation

Timothy Drysch – Head of Electrical Design

GfA ELEKTROMATEN UK Ltd

Partly completed machinery according to the Supply of Machinery (Safety) Regulations 2008 must not be put into service until the final machinery into which it is to be incorporated has been declared in conformity with the provisions of the directive.

Authorised Signature

Name: Andrew Collett

Title: Managing Director

Date

01/01/23

Supplied by:

GfA ELEKTROMATEN UK Ltd

Agincourt Road, Warwick,
CV34 6XZ United Kingdom

Telephone: 01926 452452 Fax: 01926 336417

E-mail: sales@gfa-elektromaten.co.uk

Web Site: www.gfa-elektromaten.co.uk