



# Installation Instructions

**ELEKTROMAT SE 15.48-25,40**

**NOT DEFINED**

Model: 10004112 10006

**-en-**

Status: 16.11.2022

GfA ELEKTROMATEN UK Ltd  
Titan Business Centre  
Spartan Close  
Warwick CV34 6RR  
United Kingdom  
[sales@gfa-elektromaten.co.uk](mailto:sales@gfa-elektromaten.co.uk)  
[www.gfa-elektromaten.co.uk](http://www.gfa-elektromaten.co.uk)

## Table of contents

1	General safety information .....	4
2	Technical data .....	6
3	Mechanical installation .....	7
4	Electrical installation .....	11
5	Limit switch adjustment .....	13
6	Motor connection .....	14
7	Alternative motor connection.....	14
8	Limit switch connection .....	15
9	Emergency manual operation (hand chain operator).....	16
10	Completing commissioning / inspection.....	18
11	Disposal.....	20
12	Declaration of incorporation / Declaration of conformity.....	21
13	UKCA: Declaration of incorporation / Declaration of conformity.....	22

### Symbols



**Warning** - Potential injury or danger to life!



**Warning** - Danger to life from electric current!



**Note** - Important information!



**Requirement** - Required action!

Schematic representations are based on product examples. Deviations from delivered products are possible.

# 1 General safety information

## **Specified use**

The drive unit is only intended for vertically moving doors. Doors that must be secured against dropping require a separate safety brake.

The drive unit must be protected against moisture and aggressive environmental conditions (such as corrosive substances). The drive units are only suitable for indoor use. Appropriate protective measures must be taken for outdoor installation. The drive unit is not intended for hazardous areas. The values specified in the technical data of the drive unit must not be exceeded. The safe operation can only be ensured if used as specified.

## **Target audience of these installation instructions**

These installation instructions are geared towards qualified persons trained in the handling of door systems. Expert knowledge, relevant skills and practical experience are what set apart qualified persons. They are capable of safely carrying out the tasks involving installation, maintenance and modernisation according to the instructions.

## **Safe operation**

The safe operation of the product can only be ensured if it is used as specified. Follow the installation instructions. Observe all specifications, especially warnings, when installing the product in the overall system. GfA is not liable for damage resulting from non-observance of the installation instructions. The resulting overall system must be reassessed for its safety in accordance with applicable standards and directives (e.g. CE marking). These installation instructions refer only to a part of the overall system and are not sufficient as the sole instructions for the overall system. The installer of the system must prepare the instructions for the overall system. We recommend entering the danger area of the system only when the drive unit is at a standstill.



**Warning - Failure to follow these installation instructions may result in severe injury or death.**

- Please read these instructions before using the product.
- Keep these instructions handy.
- Include these instructions when passing on the product to third parties.



**Warning - Danger from improper use of the product!**

- Do not let children operate the product unsupervised or use as a toy.



**Warning - Danger to life from incorrect installation!**

Work carried out improperly may result in death or severe injury from electrical current or falling parts.

- Allow only competent people to carry out the work.
- Disconnect all cables from the power supply.
- Observe valid regulations and standards.
- Use suitable tools.



**Warning! Danger to life from falling objects if the drive unit is subjected to impermissible forces.**

Inadmissible forces (examples: collision with a forklift, dropping the drive unit, tearing or pulling on the motor) lead to damage to the drive unit. There is a risk of severe injury or death from falling objects.

- Prevent impermissible forces from acting on the drive unit,
- Check the drive unit for damage if impermissible forces have acted on it. Look even for minor damage. Lock the door during the inspection.
- Contact the service department if you have difficulty assessing the damage.

## 2 Technical data

Designation		Unit
Output speed	48	rpm
Output torque	150 (99) <sup>1)</sup>	Nm
Output / hollow shaft	25,40	mm
Series	SG 63	-
Limit switch range (maximum revolutions of the output / hollow shaft)	40	-
Supply voltage	3~ 400	V
Operating current	2,00	A
Operating frequency	50	Hz
Power factor cos $\varphi$	0,50	-
Safety circuit	24	V
Degree of protection	IP 65	-
Temperature range	-10 / +40 (+60) <sup>2)</sup>	°C
Operating sound pressure level	< 70	dB(A)
Maximum output speed OPEN / CLOSE for frequency inverter operation	48 / 48	min <sup>-1</sup>
Cycles per hour	11 (5,6) <sup>1)</sup>	h <sup>-1</sup>
Max. holding torque	160	Nm
Braking torque	9	Nm
Braking voltage	103-130	V DC
Rectifier type	EGR 230/103	-
Manual force emergency manual operation	87	N

1) Specification in ( ) according to EN 60335-2-103.

2) When using a temperature range of +40°...+60°C use half of maximum cycles per hour.

### 3 Mechanical installation

#### Prerequisites

The permissible loads on walls, fastenings, mountings and transmission elements must not be exceeded, even for maximum holding torques or locking torques (► refer to technical data).

#### Connection elements

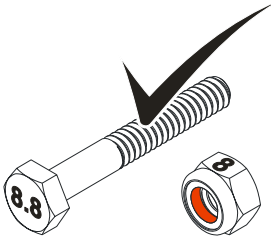
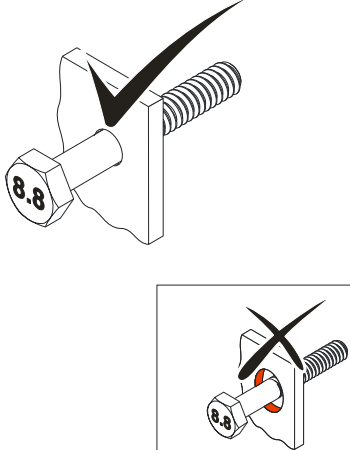
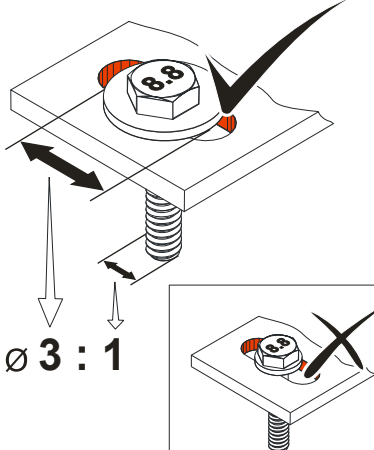
<p>► Self-locking connection elements with a minimum strength of 800 N/mm<sup>2</sup> (8.8) must be used.</p>	<p>► Utilize the hole diameter to the full.</p>	<p>► Use adequately dimensioned washers for elongated holes.</p>
<p><small>BAGAB00001_2002</small></p>  <p><b>≥ 800 N/mm<sup>2</sup></b></p>	<p><small>BAGAB00002_2002</small></p> 	<p><small>BAGAB00003_2002</small></p>  <p><b>Ø 3 : 1</b></p>

#### Permissible mounting positions

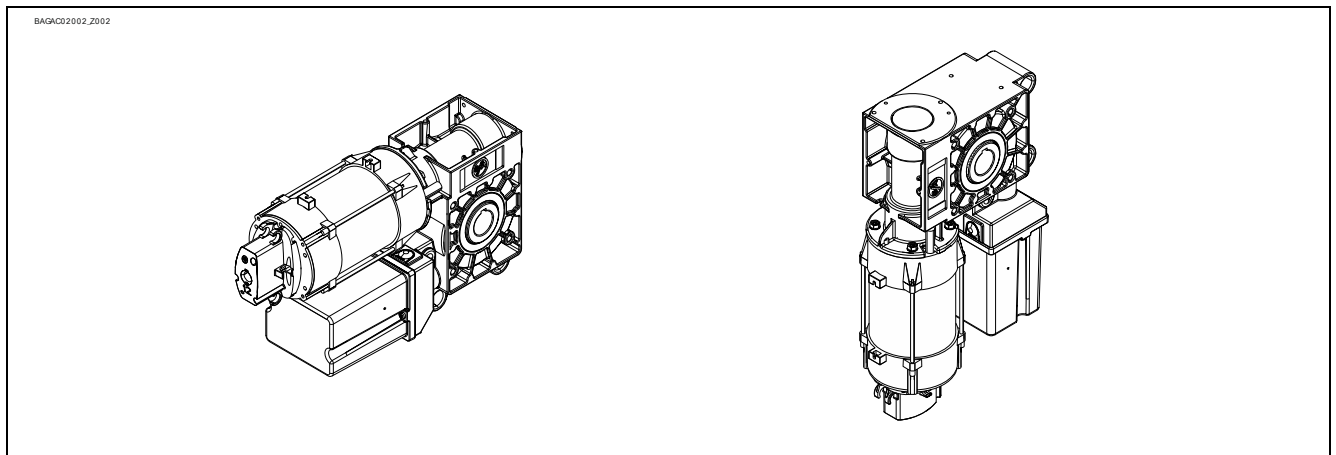

## Mounting

Eight threads are provided for mounting (①).

A key is used to connect to the door shaft.

- ▶ Use a key that is at least as long as the hollow shaft (②).

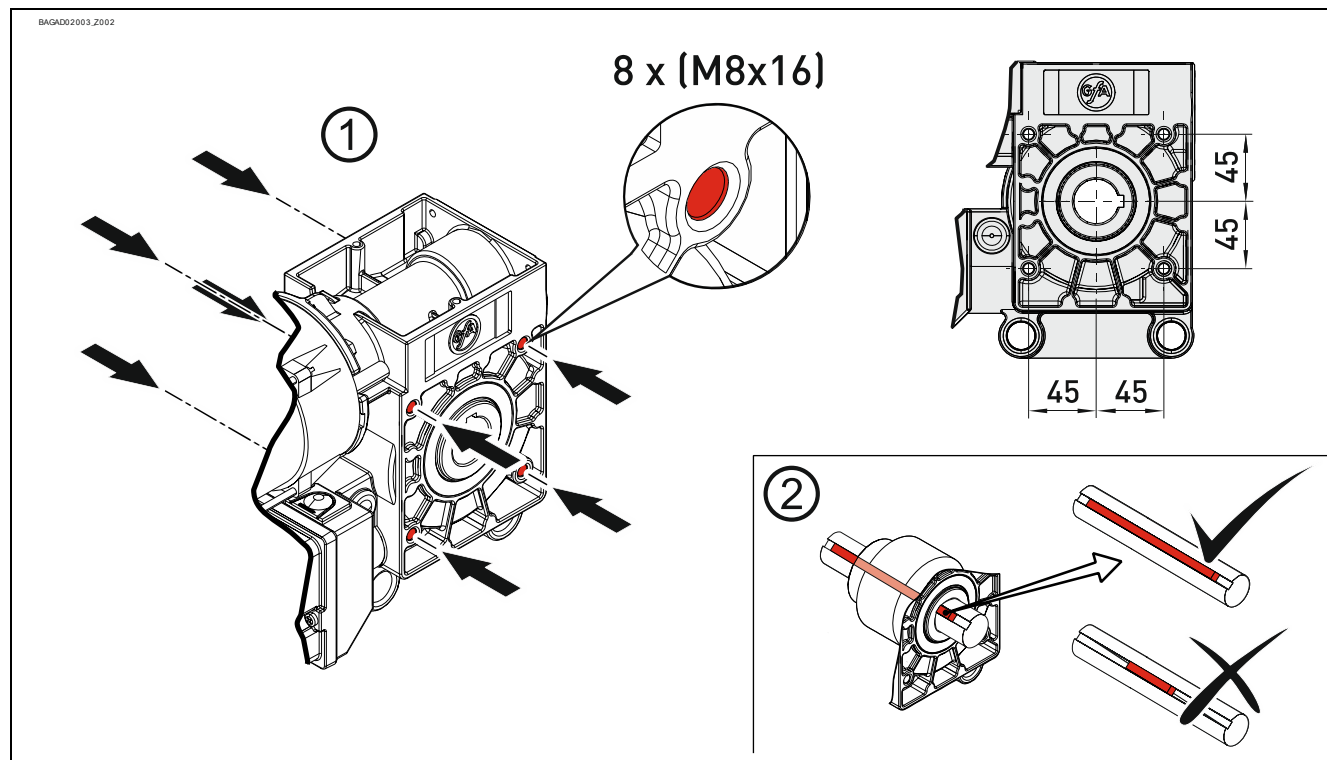



## Installation

The descriptions below apply to general door specifications. The specifications of the door manufacturer must also be observed during installation.



Warning - Potential injury or danger to life!

- During installation, be sure to use a lifting device that has a sufficient load-carrying capacity.

- ▶ Thoroughly grease the door shaft.

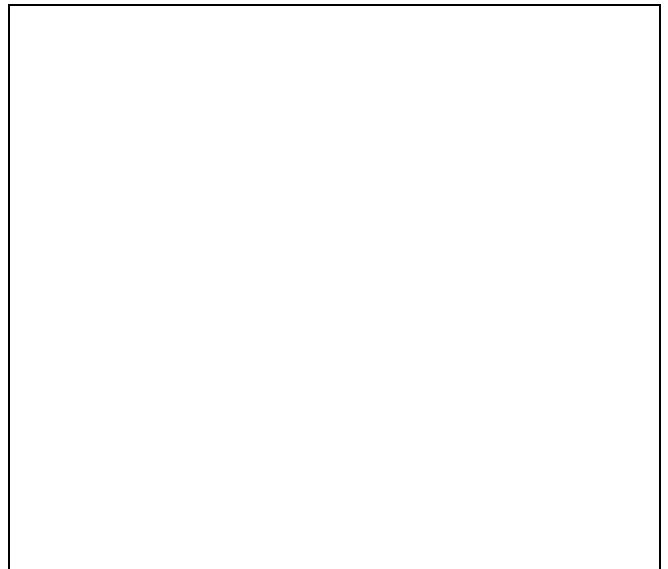

- ▶ Mount the keys. Pay attention to the possible versions (A) or (B).

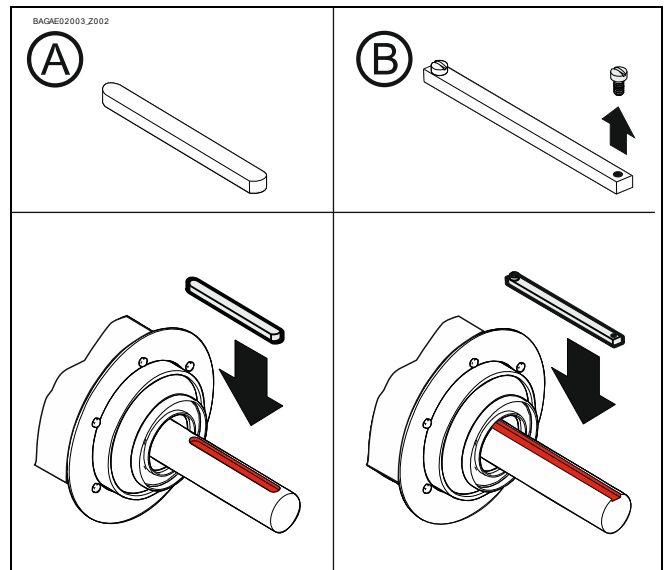

- ▶ Attach the drive unit.

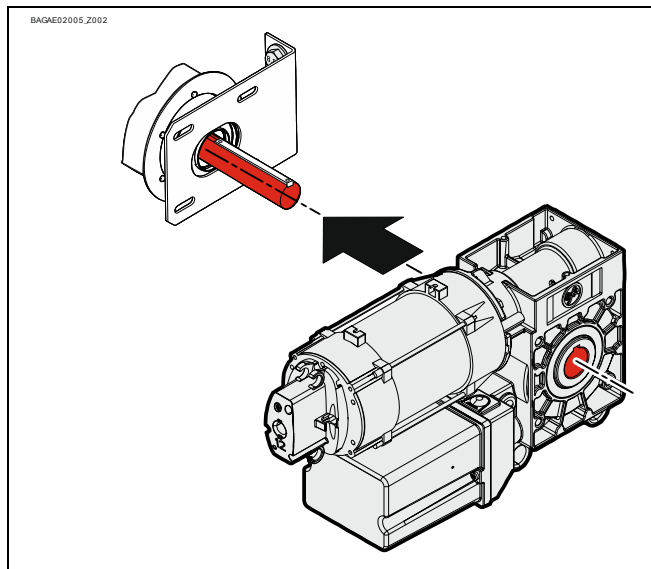

- ▶ Tighten all connection elements (M8) to 25 Nm. Install all other connection elements according to the specifications of the door manufacturer.

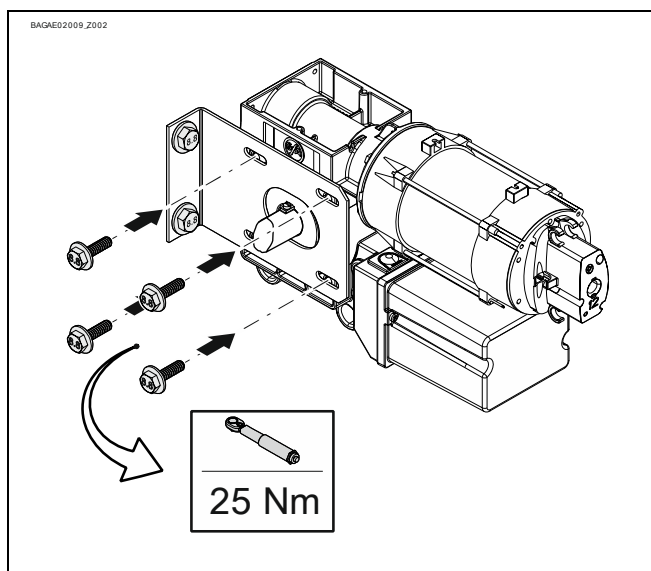

- ▶ Secure the keys (version ® only).

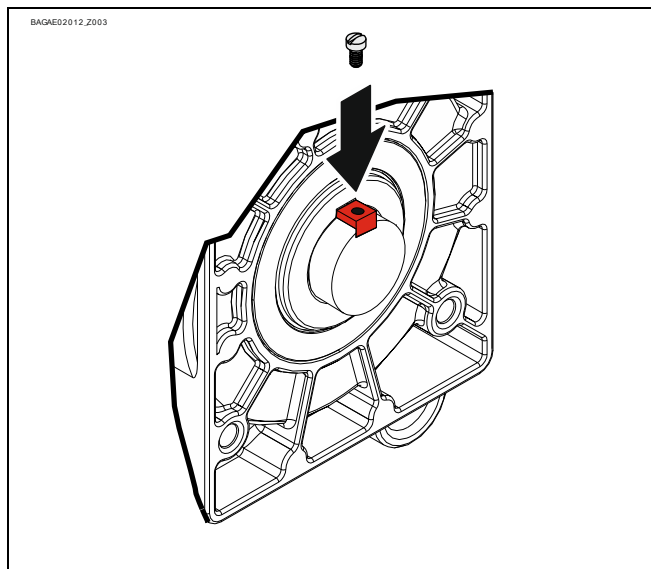

## 4 Electrical installation



**Warning - Danger to life from electric current!**

- Switch the mains OFF and check that the cables are de-energised
- Observe the applicable regulations and standards
- Make the electrical connection according to standard
- Use suitable tools

- Remove the cover.

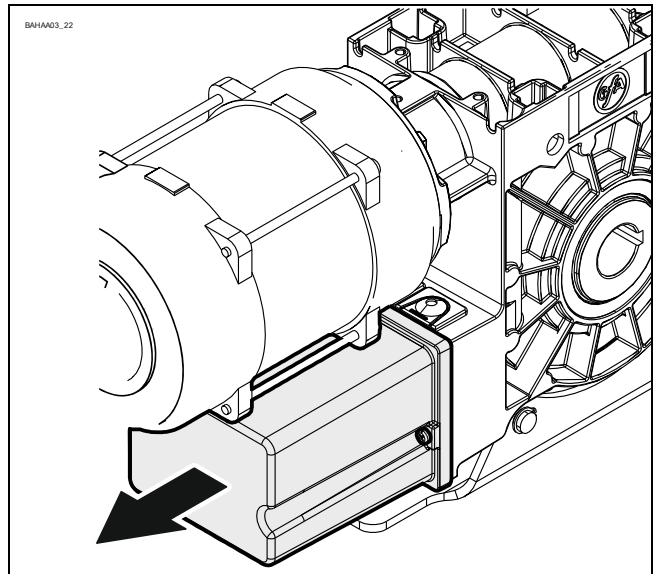

- Insert the motor plug.

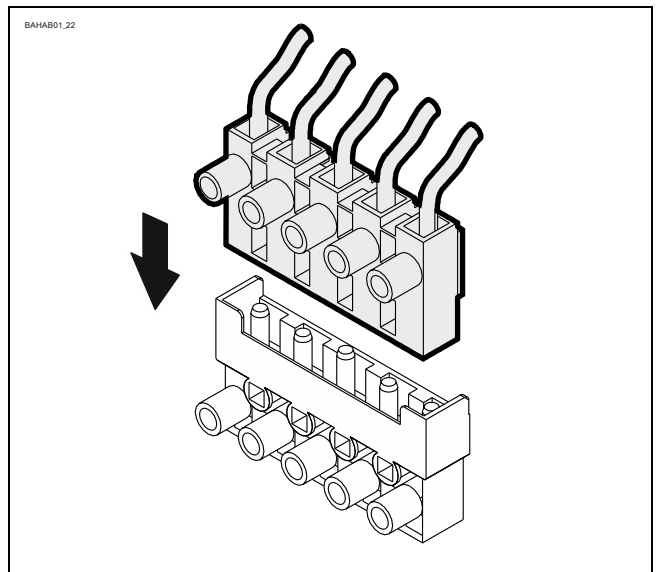

- Insert the limit switch plug.

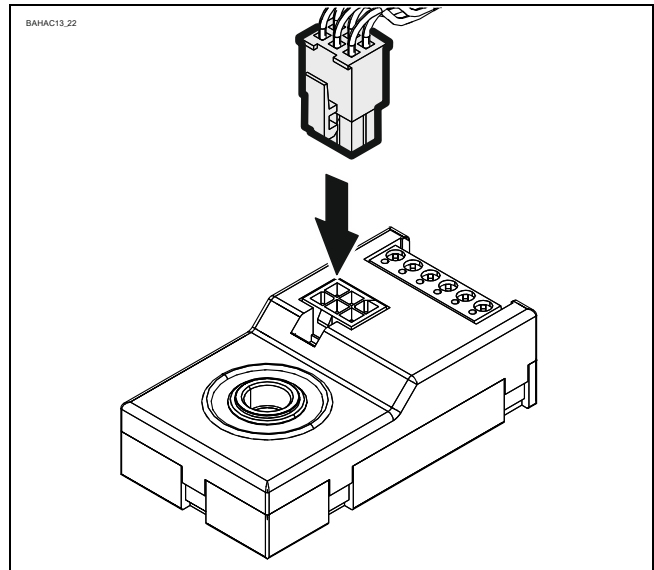

### Completing the electrical installation

Mount the cable entries and/or cable glands.

## 5 Limit switch adjustment

The adjustment of the final limit positions OPEN and CLOSE is described in the instructions for the door control panel.

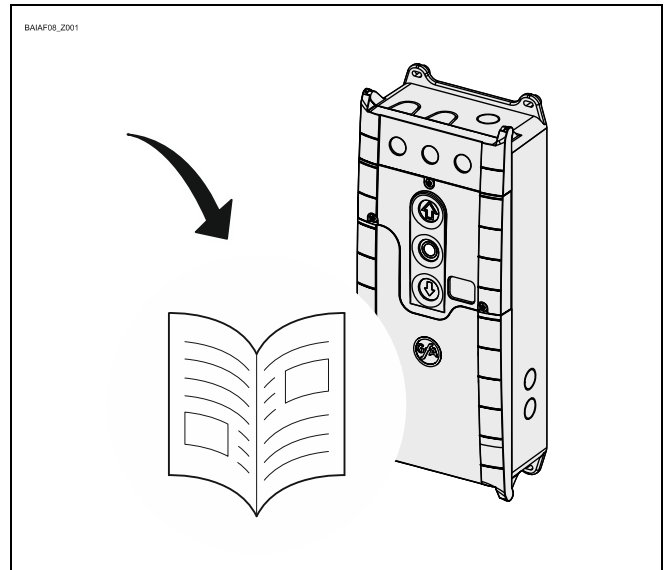

**The door control must meet Performance Level c!**

Use only door controls that evaluate the limit switch according to EN 12453 and meet Performance Level c.

## 6 Motor connection

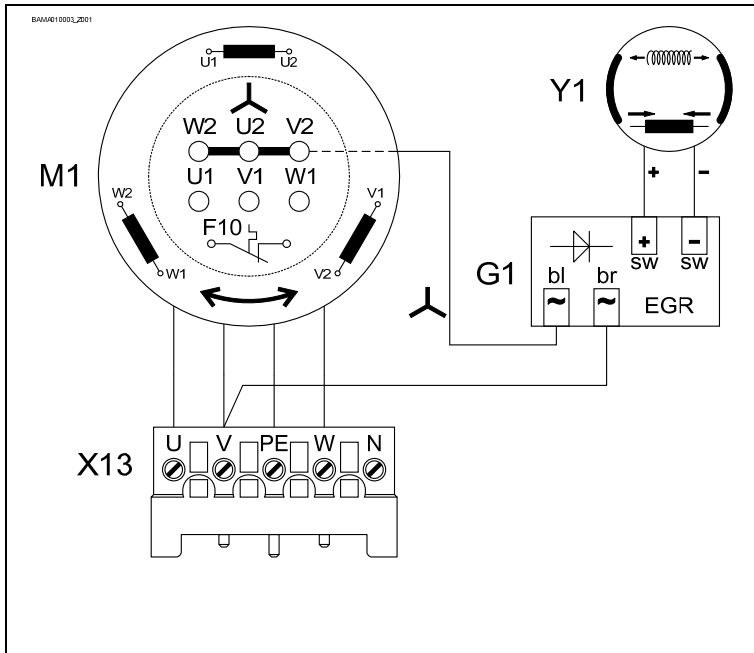

G1	Rectifier EGR
M1	Motor
X13	Motor plug
Y1	Spring applied brake

## 7 Alternative motor connection

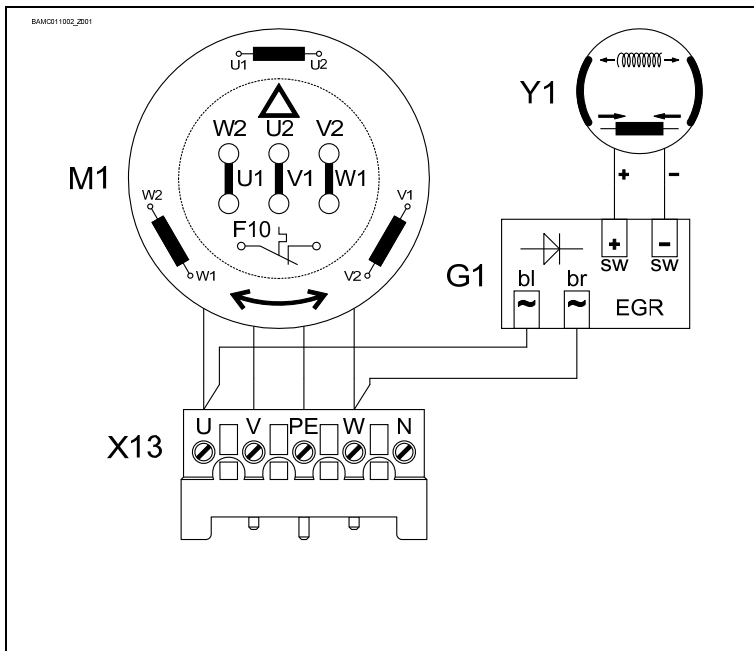

G1	Rectifier EGR
M1	Motor
X13	Motor plug
Y1	Spring applied brake

## 8 Limit switch connection

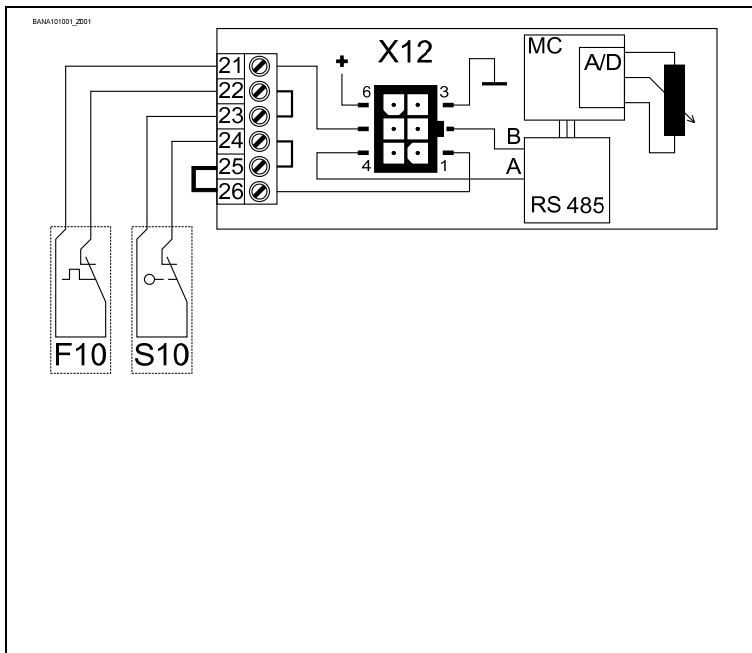

<b>F10</b>	Thermal contact
<b>S10</b>	Emergency manual operation
<b>X12</b>	DES connection
1	Safety circuit
2	Channel B (RS485)
3	Ground
4	Channel A (RS485)
5	Safety circuit
6	Supply voltage

## 9 Emergency manual operation (hand chain operator)

Emergency manual operation is designed for opening or closing the door without power supply. Its activation interrupts the control voltage. Electrical operation is no longer possible.



### Warning – Injuries due to incorrect operation!

- Switch off voltage.
- Adopt a secure position.
- For drive units with brake, the emergency manual operation must be carried out against the closed brake.



### Warning - Danger of the door dropping!

If you need to apply more than the permissible force of 390N (according to DIN EN 12604/DIN EN 12453) to move the door by emergency manual operation, this indicates a stalling on the drive unit or door. Releasing the stalling may cause the door to drop.

- Adopt a secure position.
- For drive units with brake, the emergency manual operation must be carried out against the closed brake.



### Caution – Damage to components!

- Do not move the door beyond the final limit positions.



Switch on by pulling the red handle. Open or close by pulling the chain. Switch off by pulling the green handle.

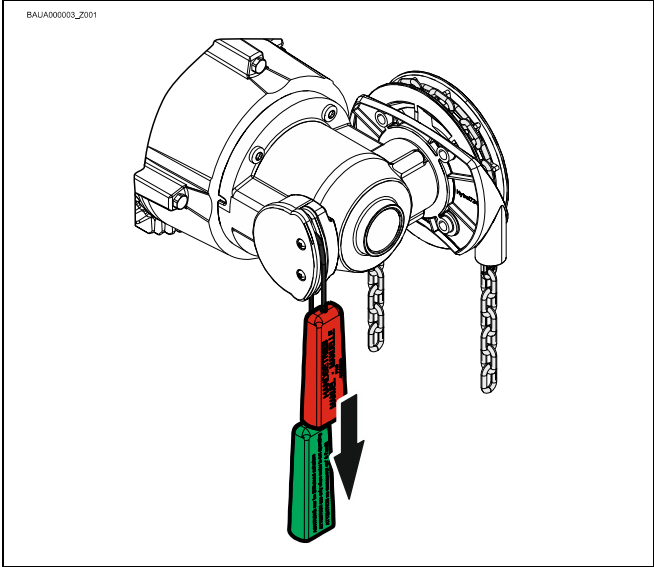

## **10 Completing commissioning / inspection**

Check the following components and then install all covers.

### **Gearbox**

Check the drive unit for loss of oil (a few drops can be neglected). Protect the output-shaft permanently against corrosion.

### **Mounting**

Check that all connection elements (consoles, torque mounts, screws, locking rings, etc.) are secure and in proper condition.

### **Electrical wiring**

Check the connection cables and cabling for damage or crushing. Check that the screw connections and plug connections are fitted properly with a good electric contact.

### **Emergency manual operation**

Check the function with the power disconnected. Perform the check only between the final limit positions.

### **Limit switch**

Check the final limit positions by opening and closing fully. The safety area must not be approached.

## Brake



### Warning - Potential injury or danger to life!

- Carry out a brake test. Overrun depends on the door and its equipment. The specifications of the door manufacturer must be observed.
- Brake lift may only be used in the final limit position CLOSE for doors that have no counter-balancing.



### Warning - Potential injury or danger to life!

Lifecycle brake - change complete brake unit at:

- Operation with mains supply after 250.000 cycles
- Operation with Inverter after 1.000.000 cycles

In an environment that can affect the coefficient of friction of the brake pad (atmosphere with oil, solvents, detergents, etc.), class of protection IP65i must be adopted.

## Drive unit



### Note!

- Engage a qualified engineer to check the drive unit annually
- Apply shorter inspection intervals for doors that are operated frequently
- Observe the applicable regulations and standards

## 11 Disposal

### Dispose of packaging

Dispose of the packaging material properly according to the local legal regulations or recycle it.

### Dispose of old devices

Dispose of old devices properly according to local legal regulations. Return old devices to the return and collection systems available. You can also return GfA products free of charge. Please apply enough postage to the package and mark it as "old devices".



#### **Notice- Environmental damage!**

The gearbox contains oil.

- Ensure proper disposal according to local legal regulations.

## Declaration of incorporation

within the meaning of Machinery Directive 2006/42/EC  
for partly completed machinery, Appendix II Part B



## Declaration of conformity

within the meaning of EMC Directive 2014/30/EU  
within the meaning of RoHS Directive 2011/65/EU

GfA ELEKTROMATEN GmbH & Co. KG  
Wiesenstraße 81 · 40549 Düsseldorf  
Germany

We,

**GfA ELEKTROMATEN GmbH & Co. KG**

declare under our sole responsibility that the following product complies with the above directives and is only intended for installation in a door system.

Drive unit

**SE 15.48-25,40**

Part no.: 10004112 10006

We undertake to transmit in response to a reasoned request by the appropriate regulatory authorities the special documents on the partly completed machinery.

This product must only be put into operation when it has been determined that the complete machine/system in which it has been installed complies with the provisions of the above-mentioned directives.

Authorised representative to compile the technical documents is the undersigned.

Düsseldorf, 10.08.2018

**Stephan Kleine**  
CEO

  
Signature

The following requirements from Appendix I of the Machinery Directive 2006/42/EC are met:

1.1.2, 1.1.3, 1.1.5, 1.2.2, 1.2.3, 1.2.6, 1.3.2, 1.3.3, 1.3.9, 1.5.1, 1.5.2, 1.5.4, 1.5.6, 1.5.7, 1.5.8, 1.5.9, 1.5.10, 1.5.11, 1.5.13, 1.6.1, 1.6.2, 1.6.4, 1.7.2, 1.7.3, 1.7.4.3.

Standards applied:

**EN 12453:2001**

Industrial, commercial and garage doors and gates - Safety in use of power operated doors - Requirements

**EN 12604:2017**

Industrial, commercial and garage doors and gates - Mechanical aspects - Requirements

**EN 60335-1:2012**

Household and similar electrical appliances - Safety - Part 1: General requirements

**EN 61000-6-2:2005**

Electromagnetic compatibility (EMC) Part 6-2  
Generic standards – Immunity standard for industrial environments

**EN 61000-6-3:2007**

Electromagnetic compatibility (EMC) Part 6-3  
Generic standards – Emission standard for residential, commercial and light-industrial environments

# Declaration of incorporation

within the meaning of Supply of Machinery (Safety) Regulations 2008  
for partly completed machinery, Appendix II Part B



# Declaration of conformity

within the meaning of Electromagnetic Compatibility Regulations 2016  
within the meaning of Restriction of the Use of Certain Hazardous Substances in  
Electrical and Electronic Equipment Regulations 2012

We,  
**GfA ELEKTROMATEN GmbH & Co. KG**  
declare under our sole responsibility that the  
following product complies with the above  
directives and is only intended for installation in a  
door system.

Drive unit  
**SE 15.48-25,40**  
Part no.: 10004112 10006

We undertake to transmit in response to a  
reasoned request by the appropriate regulatory  
authorities the special documents on the partly  
completed machinery.

This product must only be put into operation  
when it has been determined that the complete  
machine/system in which it has been installed  
complies with the provisions of the above-  
mentioned directives.

Authorised representative:  
Andrew Collett  
GfA ELEKTROMATEN UK Ltd  
Tournament Fields Business Park,  
Agincourt Rd,  
Warwick CV34 6XZ

Düsseldorf, 01.11.2022

**Stephan Kleine**  
CEO

  
Signature

The following requirements from Appendix I of  
the Supply Machinery (Safety) Regulations 2008  
are met:

1.1.2, 1.1.3, 1.1.5, 1.2.2, 1.2.3, 1.2.6, 1.3.2,  
1.3.3, 1.3.9, 1.5.1, 1.5.2, 1.5.4, 1.5.6, 1.5.7,  
1.5.8, 1.5.9, 1.5.10, 1.5.11, 1.5.13, 1.6.1, 1.6.2,  
1.6.4, 1.7.2, 1.7.3, 1.7.4.3.

Applied Standards:  
**BS EN 12453:2017+A1:2021**  
Industrial, commercial and garage doors and  
gates - Safety in use of power operated doors -  
Requirements

**BS EN 60335-2-103:2015**  
Household and similar electrical appliances -  
Safety - Part 2-103: Particular requirements for  
drives for gates, doors and windows

**BS EN 61000-6-2:2005**  
Electromagnetic compatibility (EMC) Part 6-2  
Generic standards – Immunity standard for  
industrial environments

**BS EN 61000-6-3:2007**  
Electromagnetic compatibility (EMC) Part 6-3  
Generic standards – Emission standard for  
residential, commercial and light-industrial  
environments