

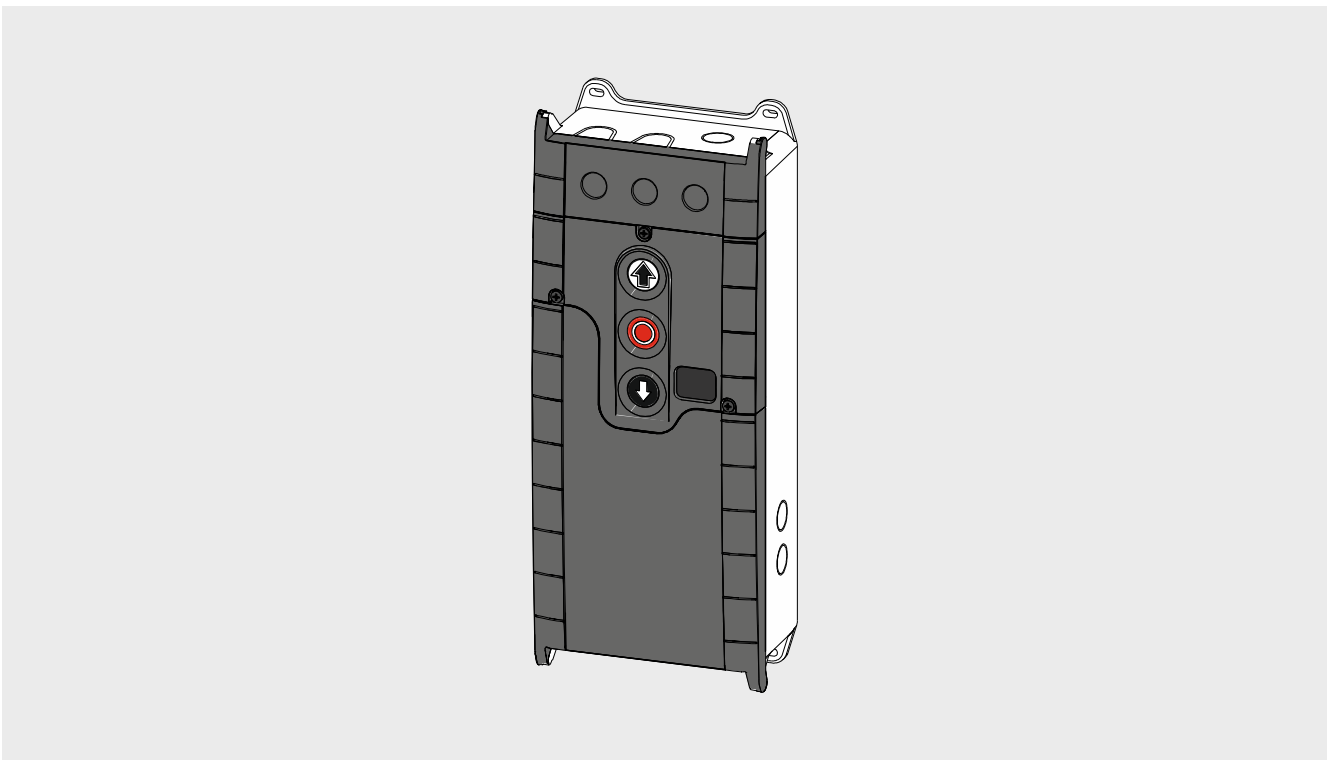

Installation Instructions

Door control - TS 970



0000000 0000 51000970 00002

-en-

51000970.00002

Status: a / 05.2023

GfA-Stick, GfA+ App and fault guide

The GfA-Stick is available for setting and servicing works on the door. Together with the GfA+ App, the tool enables reading and display of important data from GfA door controls TS 959, TS 970 and TS 971 via smartphone or tablet PC. This data includes, for example:

- Serial number, software version, cycle counter reading
- Connected hardware (e.g. sensor)
- Current programming
- Display of the last 128 events on the door
- Fault memory with fault guide for remedy

The data can be managed conveniently via the GfA-Portal.
The GfA-Portal can be reached via the GfA website:

www.gfa-elektromaten.com

Save time when testing, servicing and repairing the door. Use the GfA-Stick and GfA+ App.

Do you also need the fault guide from the App as a PDF document? You can also find this on the GfA website - in the download area.



GfA-Stick Part No.: 20003696



Germany:

GfA ELEKTROMATEN
GmbH&Co.KG
Wiesenstraße 81
40549 Düsseldorf
www.gfa-elektromaten.de
info@gfa-elektromaten.de

UK:

GfA ELEKTROMATEN UK Ltd.
Agincourt Road
Warwick
CV34 6XZ
www.gfa-elektromaten.co.uk
sales@gfa-elektromaten.co.uk

Australia:

GfA-ELEKTROMATEN
Australia Pty Ltd
P.O. Box 267
Roseville 2069 NSW
www.gfa-elektromaten.net
info@gfa-elektromaten.net

Table of contents

1	Safety-relevant chapter	5
	Explanation of symbols	5
	Intended use.....	5
	Target audience of these installation instructions.....	5
	Safe operation	6
	General safety instructions	6
2	Storage	6
3	Transport	6
4	Product overview	7
	Technical data	7
	Overview display TS 970.....	8
	Status displays of the door control	9
5	Mechanical installation	10
6	Electrical installation	11
	Overview connection cable XES	11
	Overview connection cable DES/NES	12
	Limit switch configuration, single limit switches.....	13
	Connecting door control and drive unit.....	14
	Mains supply	15
7	Connecting external devices	17
	X - Power supply 24V DC	17
	X1 - Mains supply / supply of external devices	17
	X2 - Safety devices.....	18
	X2 - Door safety switch.....	19
	X3 - Emergency Stop	20
	X4 - Switch for automatic closing.....	21
	X5 - External control device	21
	X6 - Photocell and light curtain	22
	X7 - Radio receiver / pull switch.....	23
	X8 - Switch for intermediate open	24
	X20 - Relay contact for traffic lights, light curtain or magnetic brake	24
8	Setting the final limit positions	25
9	Programming	26
	Programming the door control	26
	Explanation of the programming tables.....	26
	Menu items:	27
	P 0.1 - Operating mode	27
	P 0.2 - Output rotating direction	27
	P 1.1 / 1.2 - Coarse correction of final limit position	28
	P 1.3 – 1.5 - Fine correction of final limit positions.....	28
	P 1.6 - Door positions for intermediate open	29
	P 1.7 - Switching position of relay X20	29
	P 2.1 - Safety edge in pre-limit area	30
	P 2.2 - Overrun correction.....	30
	P 2.3 - Automatic closing.....	31
	P 2.4 - Reaction of automatic closing to photocell / light curtain.....	31
	P 2.5 - Limiting reversals	32
	P 2.6 - Radio and pull switch functions	32
	P 2.7 - Relay functions of X20.....	33
	P 2.9 - Specifying control device for intermediate open.....	34
	P 3.1 - Force monitoring of sectional doors	34
	P 3.2 - Interruption of the photocell	35

P 3.3 - Travel time monitoring.....	35
P 3.4 - Door safety switch.....	36
P 3.8 - Shorten/lengthen the reversing time.....	36
P 4.1 – 4.9 - Frequency inverter functions	37
P 8.5 - Setting the maintenance cycle counter.....	38
P 8.6 - Response after expiry of the maintenance cycle counter.....	38
P 9.1 - Readout of cycle counter	39
P 9.2 - Readout of fault indications	39
P 9.3 - Readout of the cycle counter since last programming change.....	40
P 9.4 - Readout software version	40
P 9.5 - Reset to factory settings / use of GfA-Stick.....	40
10 Fault correction.....	41
Fault indications	41
11 Maintenance.....	50
12 Disposal.....	50
Declaration of incorporation / Declaration of conformity.....	51
13 UKCA Declaration of conformity	52

1 Safety-relevant chapter

Explanation of symbols

The following symbols are used in these installation instructions:

DANGER

Safety note: Non-compliance will result in death or severe injury.

WARNING

Safety note: Non-compliance can result in death or severe injury.

CAUTION

Safety note: Non-compliance can result in injury.

NOTICE

Note: Non-compliance can result in material damage and impairment of product functionality.

NOTE

Note: Points out useful additional information.

Intended use

The door control is intended for installation in a force-actuated door with GfA limit switch system.

The drive unit must be protected against moisture and aggressive environmental conditions (such as corrosive substances). The drive units are only suitable for indoor use. Appropriate protective measures must be taken for outdoor installation. The drive unit is not intended for hazardous areas. The values specified in the technical data of the drive unit must not be exceeded. The safe operation can only be ensured if used as specified.

Target audience of these installation instructions

As a user or operator, contact the manufacturer for your door system. These installation instructions are geared towards qualified persons trained in the handling of door systems. Expert knowledge, relevant skills and practical experience are what set apart qualified persons. They are capable of safely carrying out the tasks involving installation, maintenance and modernisation according to the instructions.

A trained electrician must carry out the electrical installation. Trained electricians meet the following requirements:

- They are familiar with the applicable safety and accident prevention regulations.
- They recognise hazards relating to electricity and the door control and take safety precautions.

Safe operation

The safe operation of the product can only be ensured if it is used as specified. Follow the installation instructions. Observe all specifications, especially warnings, when installing the product in the overall system. GfA is not liable for damage resulting from non-observance of the installation instructions. The resulting overall system must be reassessed for its safety in accordance with applicable standards and directives (e.g. CE marking). These installation instructions refer only to a part of the overall system and are not sufficient as the sole instructions for the overall system. The installer of the system must prepare the instructions for the overall system. We recommend entering the danger area of the system only when the drive unit is at a standstill.

General safety instructions

⚠ WARNING

Failure to follow these installation instructions may result in severe injury or death.

- Please read these instructions before using the product.
- Keep these instructions handy.
- Include these instructions when passing on the product to third parties.

⚠ WARNING

Danger from improper use of the product!

- Do not let children operate the product unsupervised or use as a toy.

⚠ WARNING

Danger to life from incorrect installation!

Work carried out improperly may result in death or severe injury from electrical current or falling parts

- Allow only competent people to carry out the work.
- Disconnect all cables from the power supply.
- Observe valid regulations and standards.
- Use suitable tools.

2 Storage

Store the product in the original packaging.

Note the following environmental conditions for storage:

- Closed, dry, dark and vibration-free rooms
- Temperatures between +5 °C and +40 °C
- Relative humidity less than 93 %, non-condensing
- Dust protected
- Protected against corrosion (e.g. protection against saltwater)
- Protected against chemicals

3 Transport

Avoid bumps, impacts and vibrations during transport. Do not throw the product.

4 Product overview

Technical data

Designation		Expression
Dimensions (B x H x T)		155 x 386 x 90
Weight		2 kg
Operating frequency		50 Hz / 60 Hz
Supply voltage		1 N~220-230 V, PE 3 N~220-400 V, PE 3~220-400 V, PE
Output power for drive unit, maximum		3 kW
Temperature range	Operation	-10 °C - +50 °C
	Storing	0 °C - +50 °C
Air humidity, non-condensing		max. 93 %
Internal electronic protection		180 mA
Power consumption door control		11 W
Protection class	Housing	IP65
	with CEE connection kit	See the IP protection class of the connection kit
Protection per phase, on-site		10 A - 16 A
External mains supply:		24 V DC
External mains supply: X1.8 / X1.9		1 N~230 V
Protection via F1 micro-fuse		1,6 A time-lag
Relay contact		1 potential-free changeover contact
Loading of relay contacts	ohmic	230 V AC, 1 A
	inductive	24 V DC, 0,4 A
Control inputs		24 V DC, typ. 10 mA
Compatible GfA - limit switch		Mechanical limit switch (NES) Digital limit switch (DES)

Overview display TS 970

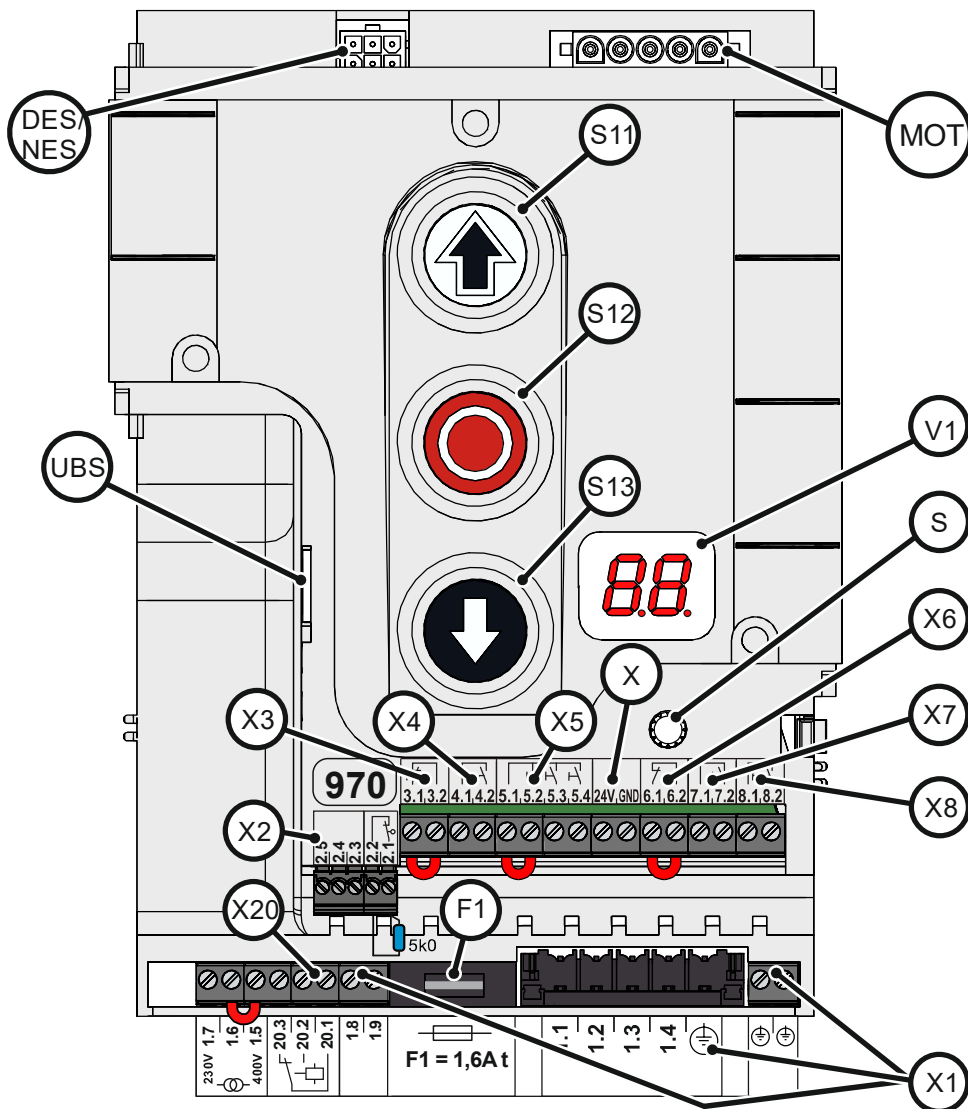

DES/ NES	DES or NES limit switch socket	X	24 V mains supply, external devices
F1	Micro-fuse 1.6 A time-lag	X1	Mains supply
MOT	Motor socket	X2	Door safety switch and safety devices
S	Selector switch	X3	Emergency STOP control device
S11	OPEN push-button	X4	Automatic closing On/Off
S12	STOP push-button	X5	Control device, external three push-button
S13	CLOSE push-button	X6	Through / reflective photo cell
UBS	Socket for universal command sensor system	X7	Pull switch, external radio receiver
V1	Display	X8	Intermediate open On/Off
		X20	Potential-free relay contact

Status displays of the door control

The display of the door control consists of a double-digit seven-segment-display. The display can show symbols, letters, or numbers.

The figure shows the display when all segments are illuminated.

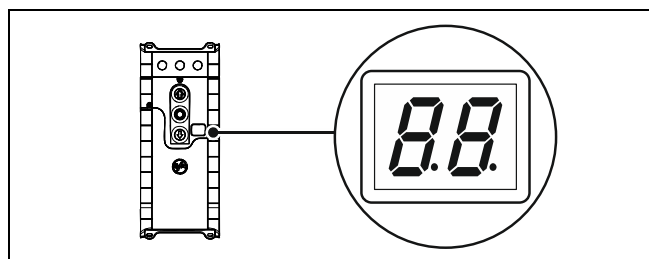

i NOTE

An *E* alternating with a number on the door control stands for a movement command.

An *F* alternating with a number on the door control stands for a fault indication. See Chapter : Fault indication.

Status display during initial operation

These symbols appear only while the final limit positions are set.

Display	Description
'.'''	Changing output rotating direction is active.
''''	Changing output rotating direction is completed.
'''' .	Flashing: Teaching in final limit position OPEN.
''''	Flashing: Teaching in final limit position CLOSE.

Status displays during operation

Display	Description
.	Standby. A movement command or pressing a pushbutton exits the standby mode.
C.5	Preset maintenance cycle counter has been reached. See menu item B.5/B.6.
8.8.	Display does not light up. Indicates a short circuit or overload of the 24V DC supply voltage.
''.'''	Flashing: Door is opening.
''.'''	Flashing: Door is closing.
''.'''	Door is stationary between two final limit positions.
''.'''	Door is in final limit position OPEN.
''.'''	Door is in programmed intermediate open.
''.'''	Door is in final limit position CLOSE.
8.8	Non-flashing: programming disabled.

Movement command display

The movement commands appear on the display when the door control receives OPEN, CLOSE or STOP commands.

Display	Description
E.	Display alternates between E. and number:
1.1	OPEN command received.
1.2	STOP command received.
1.3	CLOSE command received.

5 Mechanical installation

NOTICE

Damage to components due to extreme environmental conditions!

Extreme environmental conditions (humidity, chemical substances) at the installation site may damage the product.

- Install the product indoors only. Installed outdoors, the product must be enclosed to provide the same conditions as in an indoor environment. Ensure that the installed connection cables are protected.
- Protect the product from moisture.
- Maintain the temperature range and the maximum humidity during operation.

⚠ WARNING

Danger of shearing, crushing or being drawn in!

In operating mode hold-to-run, people or objects in the path are not detected.

The operation of the door without a line of sight leads to dangerous situations for other people.

- Mount the door control in a position with a clear view of the door.
- Operate the door in operating mode hold-to-run with a clear view of the door.

Mounting

The permissible loads on walls, mountings, connection and transmission elements must not be exceeded.

- Mount the door control through the 4 elongated holes.

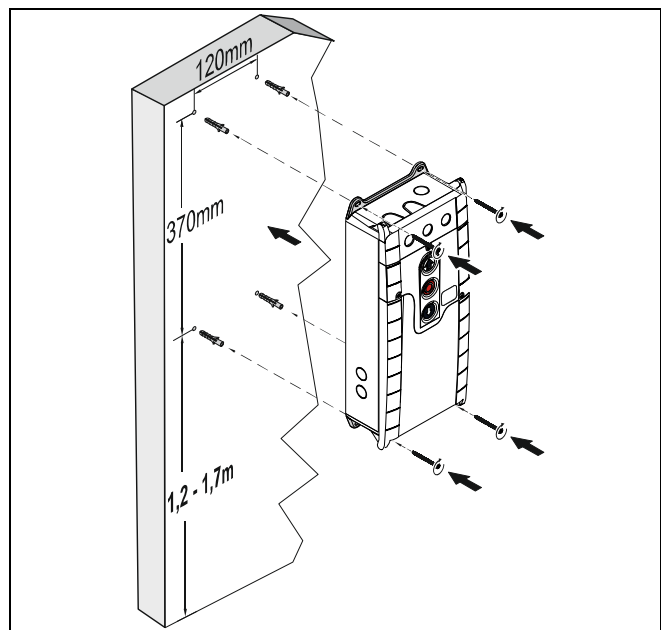

6 Electrical installation

⚠ WARNING

Danger to life from electric shock!

Improper wiring may result in severe or fatal injury from electrical current.

- Allow only qualified electricians to carry out the work.
- Disconnect all cables from the power supply.
- Secure the mains disconnecter against plugging in or switching it on again.
- Observe valid regulations and standards.
- Use suitable tools.

⚠ WARNING

Mortal danger due to inadequate fuse!

Without the correct on-site backup fuse and mains disconnecter, there is a risk of fatal or severe injury from electrical current.

- Carry out the connection to the indoor installation using an all-pole disconnecter unit of ≥ 10 A as per EN 12453 (e.g. CEE plug connection, main switch).
- Use a Type B residual current circuit breaker for a drive unit with a 3-phase frequency inverter.

Overview connection cable XES

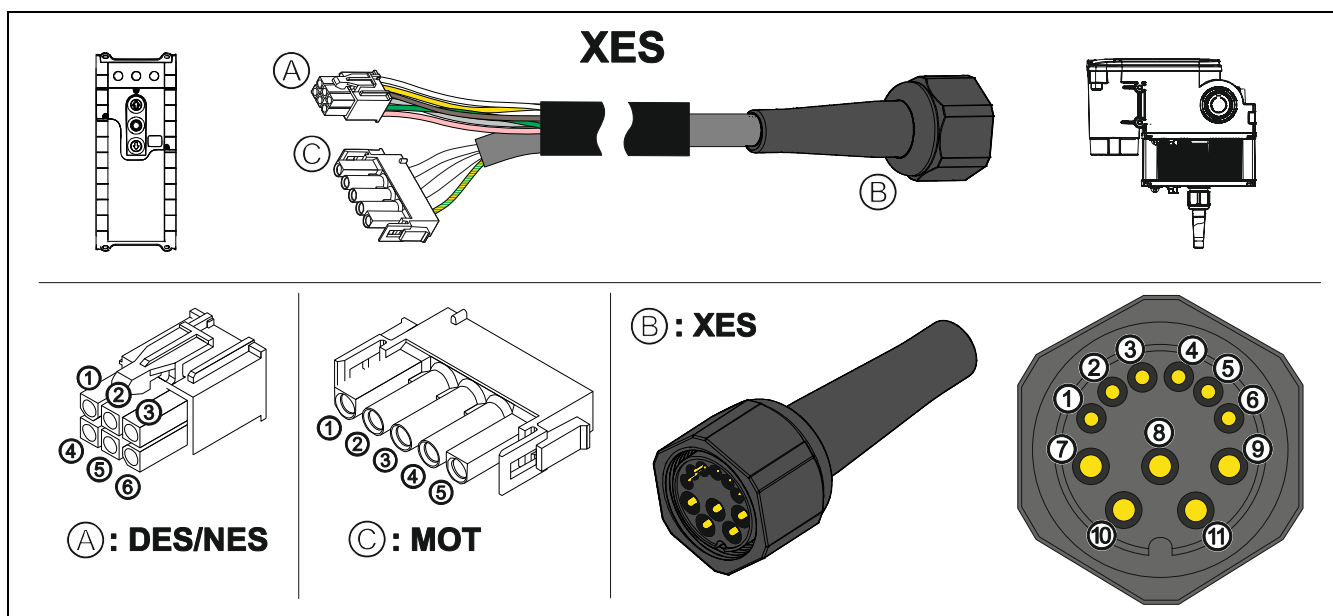

(A) DES ↔ (B) XES

Pin	Core	Pin	Description
①	5/ws	①	Safety circuit +24 V
②	6/br	②	Channel B (RS485)
③	7/gn	③	Ground
④	8/ge	④	Channel A (RS485)
⑤	9/gr	⑤	Safety circuit
⑥	10/rs	⑥	Supply voltage 8 V DC

(C) MOT ↔ (B) XES

Pin	Core	Kl.	Description
⑦	3	W	Phase W
⑧	2	V	Phase V
⑨	1	U	Phase U
⑩	4	N	Neutral conductor (N)
⑪	PE	PE	

Overview connection cable DES/NES

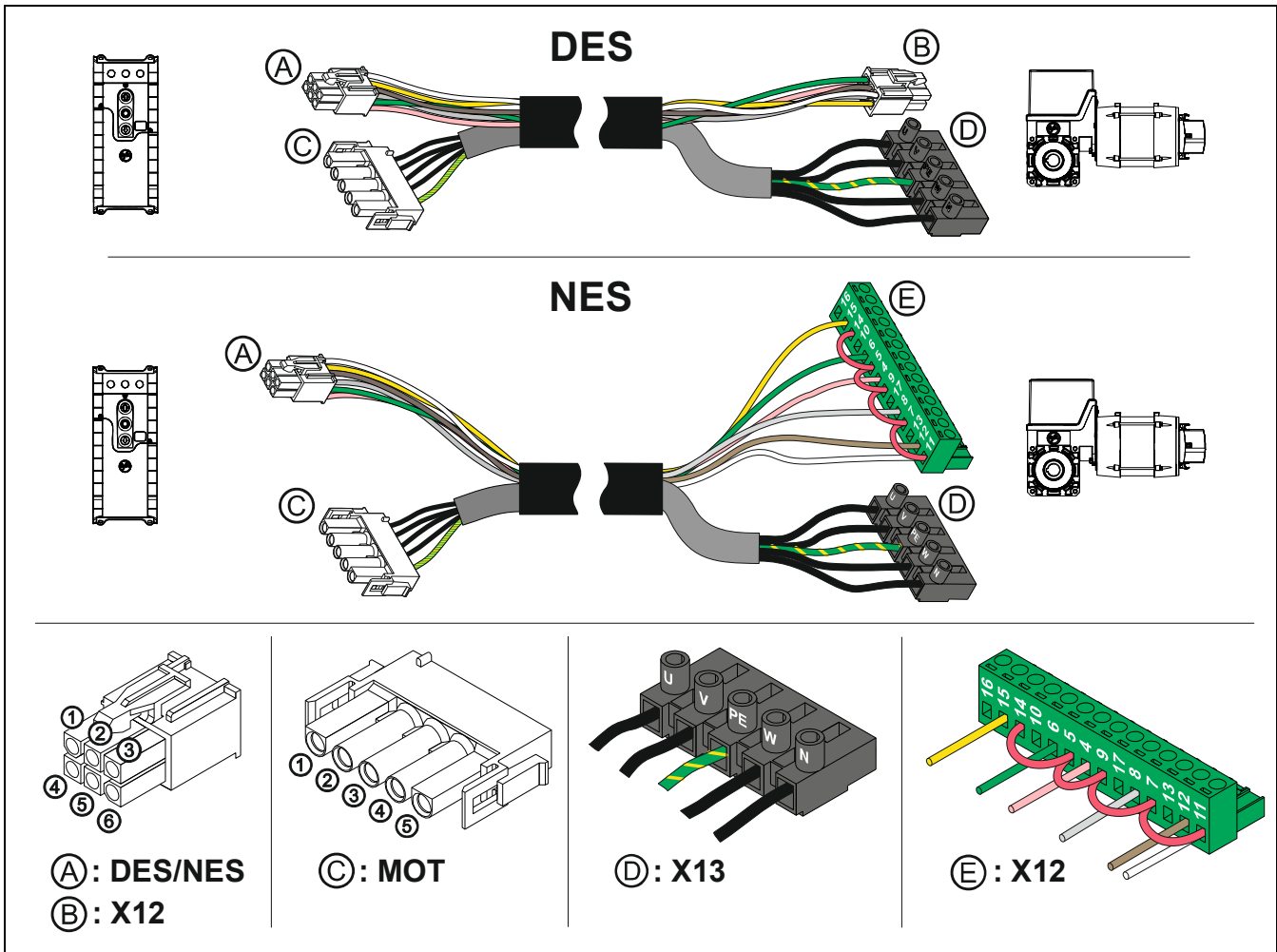

A DES ↔ B X12			
Pin	Core	Pin	Description
①	5/ws	①	Safety circuit +24 V
②	6/br	②	Channel B (RS485)
③	7/gn	③	Ground
④	8/ge	④	Channel A (RS485)
⑤	9/gr	⑤	Safety circuit
⑥	10/rs	⑥	Supply voltage 8 V DC

C MOT ↔ D X13			
Pin	Core	Kl.	Description
①	3	W	Phase W
②	2	V	Phase V
③	1	U	Phase U
④	4	N	Neutral conductor (N)
⑤	PE	PE	

A NES ↔ E X12			
Pin	Core	Kl.	Description
①	5/ws	11	Limit switch common +24 V, wire link to: 7, 9, 5, 14v
②	6/br	12	S5 Auxiliary limit switch
③	7/gn	6	S3 OPEN limit switch
④	8/ge	15	S6 Auxiliary limit switch
⑤	9/gr	8	S4 CLOSE limit switch
⑥	10/rs	4	Safety circuit

Limit switch configuration, single limit switches

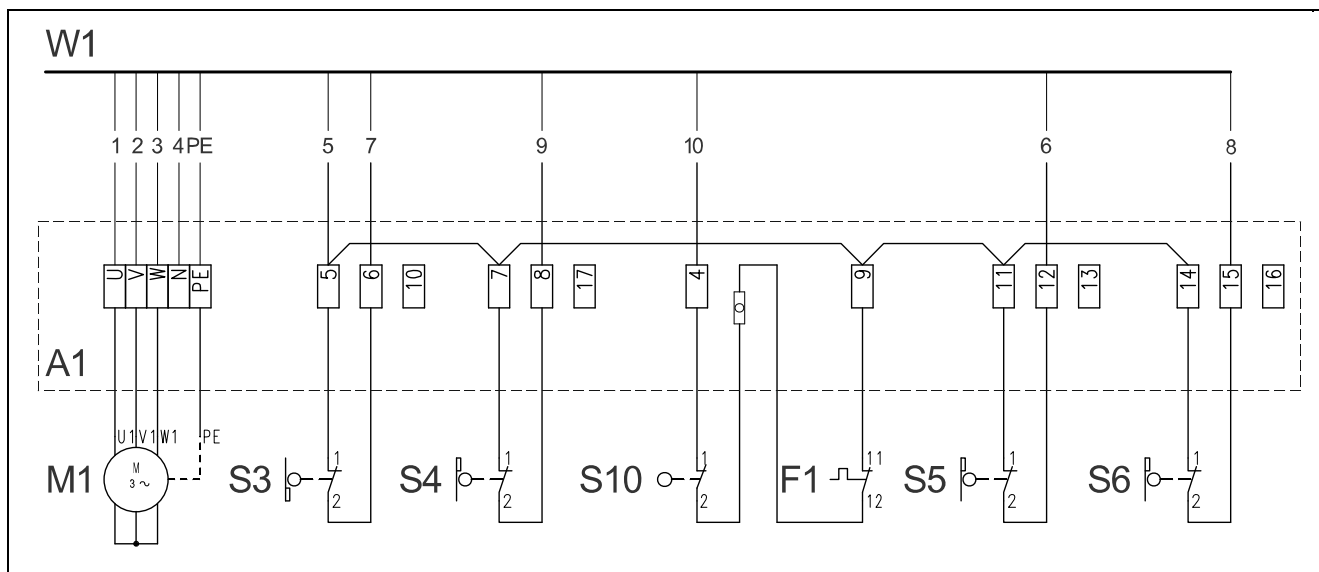

W1	Connection cable
A1	Terminal box
F1	Thermal contact
M1	Motor
S10	Emergency manual operation

S3	OPEN limit switch
S4	CLOSE limit switch
S5	Auxiliary limit switch
S6	Auxiliary limit switch

Connecting door control and drive unit

NOTICE

Damage to the product due to work carried out improperly

- Use proper tools to prevent damage and leakage.
- We recommend wiring the door control from below.

1. Remove the covers.

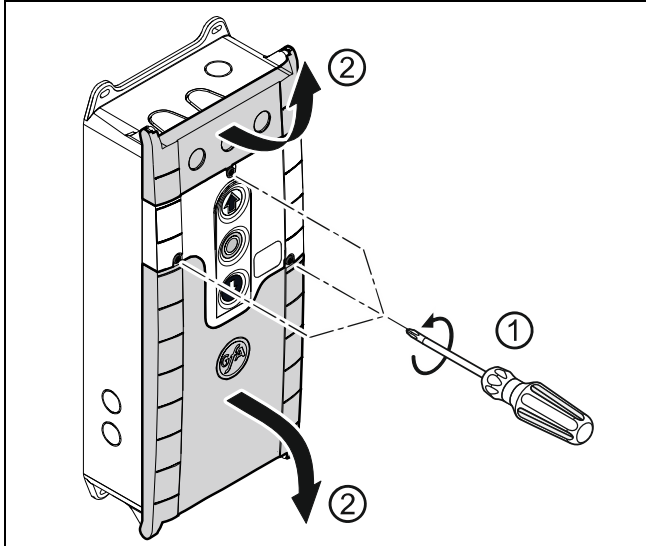

2. Open the cable entries at the top or bottom.

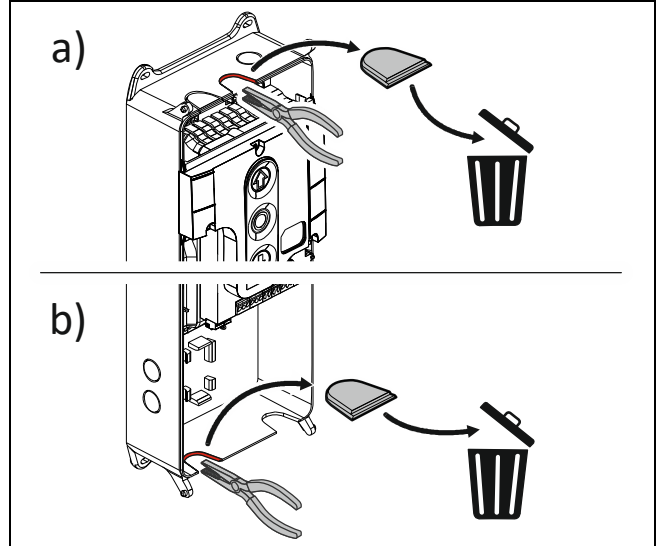

3 a) Connection cable at the top:

- Run the connection cable through the housing and insert the plugs.
- Tighten the cable gland.

3 b) Connection line at the bottom:

- Run the connection cable through the housing and insert the plugs.
- Tighten the cable gland.

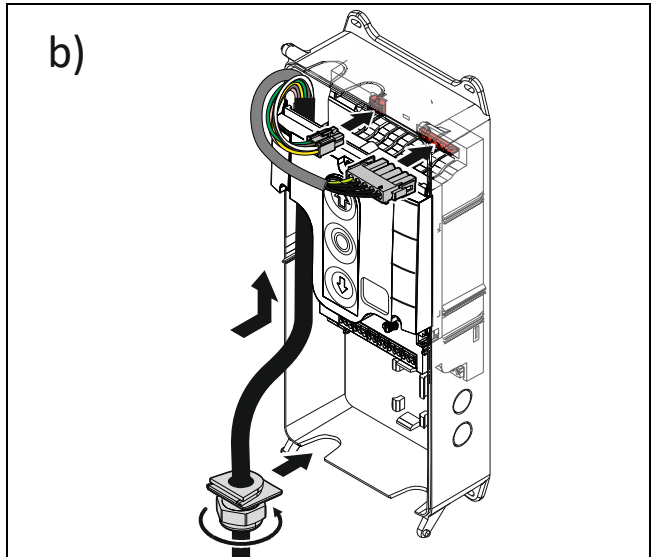
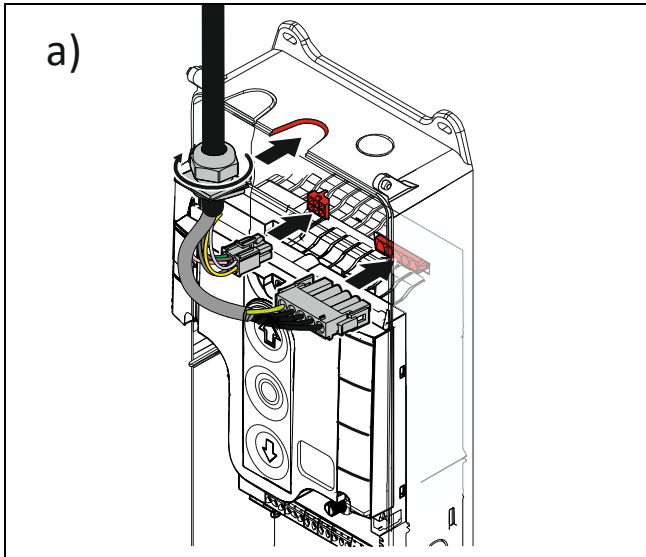

NOTICE

Damage due to moisture or penetrating foreign bodies

- Check that all cable glands are tight.
- Seal open and unused cable entries with blanking plugs. This will prevent moisture or foreign bodies such as insects from penetrating.

Mains supply

Before connecting, check whether a clockwise rotating field is present at the installation site. If not, create a clockwise rotating field.

3-phase with neutral $3\sim$, N, PE 220–400 V / 50-60 Hz	3-phase without neutral $3\sim$, PE 220–400 V / 50-60 Hz	1-phase symmetrical $1\sim$, N, PE, sym. 220–230V / 50-60 Hz	1-phase asymmetrical $1\sim$, N, PE, asymmetrical 220–230 V / 50-60 Hz

Position of the transformer bridge

The door control can be operated with different mains voltages (see figures below).

- Ensure the correct position of the transformer bridge according to the mains voltage on site.

NOTICE

Damaging or destroying the product

The door control is always factory-set to the highest voltage.

- Install the bridge as shown below.

3 ~ 400 V

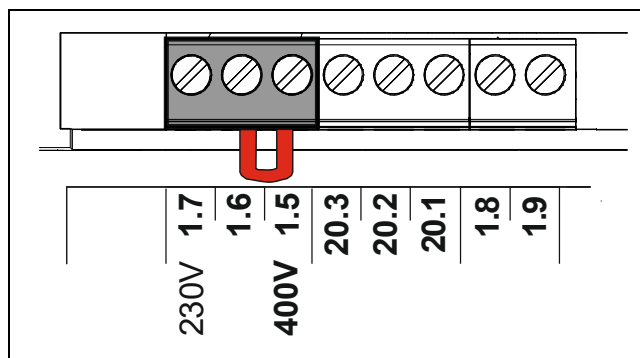

1 ~ 230 V / 3 ~ 230 V

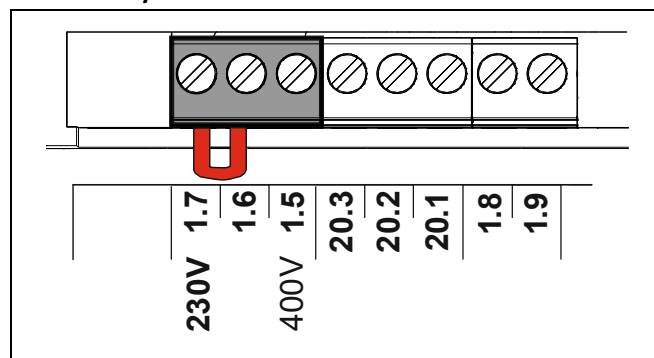

- Run the connection cable through the housing and insert the plugs.
- Tighten the cable gland.

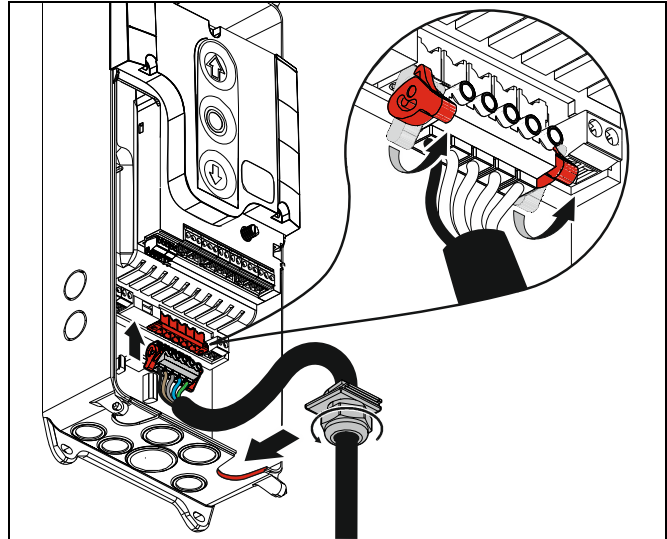

NOTICE

Damage due to moisture or penetrating foreign bodies

- Check that all cable glands are tight.
- Seal open and unused cable entries with blanking plugs. This will prevent moisture or foreign bodies such as insects from penetrating.

7 Connecting external devices

⚠ WARNING

Danger to life from electric shock!

Improper wiring may result in severe or fatal injury from electrical current.

- Allow only qualified electricians to carry out the work.
- Disconnect all cables from the power supply.
- Secure the mains disconnecter against plugging in or switching it on again.
- Observe valid regulations and standards.
- Use suitable tools.
- Check the insulation of cables and make sure that cables outdoors are protected.

i NOTE

The inputs of the following safety devices of the control are rated Performance Level c (PLc):

- Slack-rope switch
- Pass-door switch
- Safety edge
- Limit switch system
- Safety circuit of the drive unit
- Emergency STOP control device

i NOTE

Connect only sensors that comply with the current EN 12453 and are suitable for Performance Level c.

X - Power supply 24V DC

Connect external devices that require 24 V DC to terminals X 24 V/GND. For example, photocells, radio receivers and relays.

NOTICE

Damage to components!

The total current consumption of external devices must not exceed 180 mA.

X1 - Mains supply / supply of external devices

Mains supply of the door control.

Note the chapter "Electrical installation / mains supply".

i NOTE

Supply of external devices

External devices can only be supplied with power over terminals X1/1.8 and X1/1.9 when the door control is connected symmetrically to supply networks with 3 N~ 400 V or 1 N~ 230 V.

- Fuse protection by F1, micro fuse 1.6 A slow blow.

X2 - Safety devices

You can connect three different types of safety edges to terminals X2.1 to X2.5.

- Mount the product according to the manufacturer's instructions.
- Use a spiral cable to connect the safety devices to the door control. When using spiral cables, we recommend routing the cable through the side of the door control box.
- Follow the assembly instructions for the products.

i NOTE

In case of a defective safety edge, the door control switches to operating mode hold-to-run.

Electrical safety edge

The input is designed for an electrical safety edge (NO) with a terminal resistance of 8k Ω (+/- 5 % and 0.25 W).

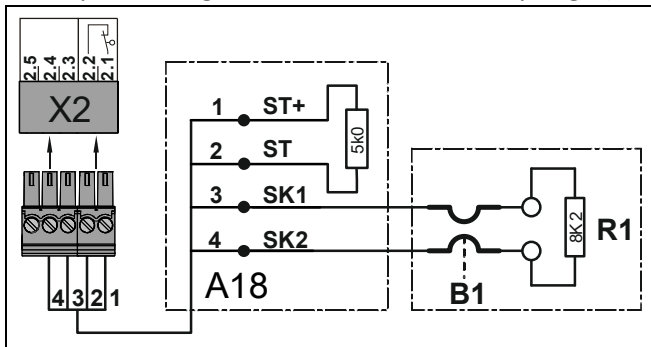

A18	Connection socket
ST+	Voltage supply (12 V)
ST	Input for door safety switch
SK1	Input for electrical safety edge
SK2	
B1	Electrical safety edge
R1	End of line resistor (8k Ω)
X2	Door control socket

i NOTE

Following a short circuit of the electrical safety edge, fault indication *F 2.4* appears. When the circuit is interrupted, fault indication *F 2.5* appears.

Optical safety edge

The input is intended for an infrared safety photocell with a transmitter and receiver in a rubber profile. Pressing the rubber profile interrupts the light beam.

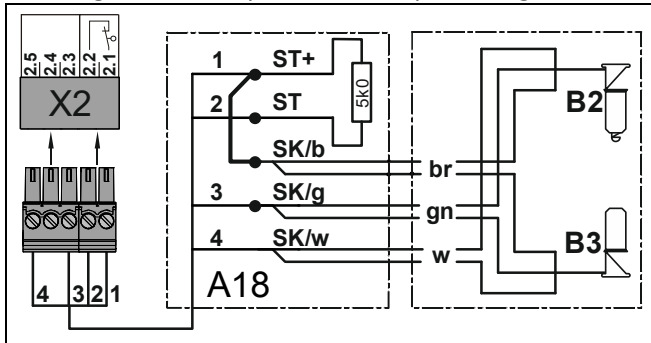

A18	Connection socket
ST+	Voltage supply (12 V)
ST	Input for door safety switch
SK/b	Mains supply (brown)
SK/g	Output (green)
SK/w	Ground (white)
B2	Optical transmitter
B3	Optical receiver
X2	Door control socket

i NOTE

When the optical safety edge is activated or damaged, fault indication *F 2.9* appears.

Pneumatic safety edge

The input is designed for a pressure-wave switch system (NC) with a terminal resistance of 1k Ω (+/-5 % and 0.25 W). The pressure wave switch system needs to be tested with final limit position CLOSE. The test phase is initiated by pre-limit switch S5 (automatically for DES). If no switching signal is generated at the pressure wave switch within 2 seconds, the test is negative and fault indication *F 2.6* appears.

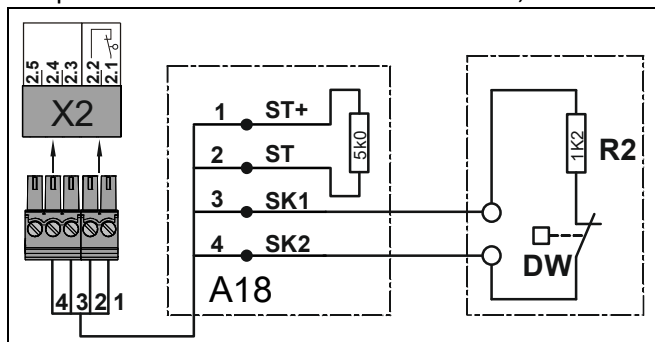

A18	Connection socket
ST+	Voltage supply (12 V)
ST	Input for door safety switch
SK1	Input for pneumatic safety edge
SK2	
DW	Pressure-wave switch
R2	End of line resistor (1k Ω)
X2	Door control socket

i NOTE

When the pneumatic safety edge is activated or the current circuit is permanently interrupted, fault indication *F 2.6* appears. Fault indication *F 2.7* appears in case of a short circuit.

X2 - Door safety switch

You can connect a door safety switch for a pass door or slack-rope switch to terminals X2.1/2.2. The door safety switches are connected to a safety circuit with Performance Level c (PLc) according to ISO 13849-1. The safety circuit requires an overall terminal resistance of 5k Ω for line cross-circuit monitoring.

Examples of door safety switches are shown below. Connect your product accordingly.

Mount the product according to the manufacturer's instructions.

i NOTE

- When activated while the door is moving, the door stops and fault indication *F 1.2* appears.
- When the switch fails, fault indication *F 1.7* is displayed.
- In the case of a line cross-circuit, fault indication *F 1.8* is displayed.

Slack-rope switch / electronic pass-door switch

The evaluation of the door control provides for the connection of two slack-rope switches.

Resistance for line cross-circuit monitoring when using slack rope switches: 1k Ω

Resistance for line cross-circuit monitoring when using electronic pass-door switches: 2k Ω

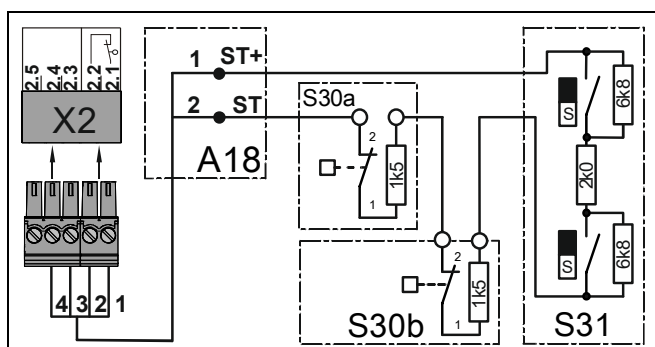

A18	Connection socket
ST+	Voltage supply (12 V)
ST	Input for door safety switch
S30a/b	Slack-rope switch (NC contact)
S31	Electronic pass-door switch

Crash switch as NC or NO contact

When the door leaf is outside the guide, the crash switch triggers. Fault indication *F 4.5* appears. The operating mode is switched to hold-to-run. Door movement is only possible using the keypad on the door control's housing. *F 4.5* only disappears when the switching contact is closed again.

Resetting *F 4.5* is only possible in the final limit position OPEN by pressing the STOP button on the door control for 3 seconds or by switching the mains voltage off and on.

i NOTE

An automatic reset to the final limit position OPEN is possible by using *P 3.4 (4 / 5)* "Reversing". Resetting takes place as soon as the switching contact is closed.

Crash switch as NC contact

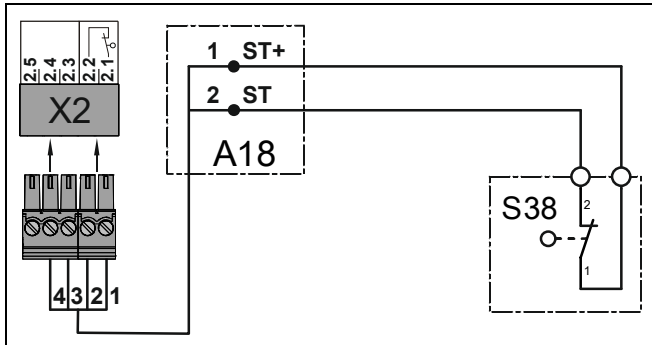

A18	Connection socket
ST+	Voltage supply (12 V)
ST	Input for door safety switch
S38	Crash switch (NC contact)

Crash switch as NO contact

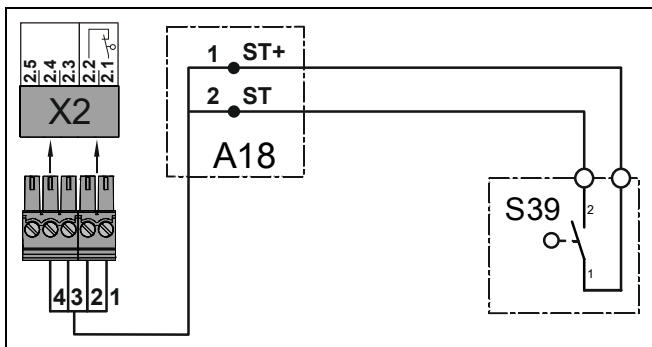

A18	Connection socket
ST+	Voltage supply (12 V)
ST	Input for door safety switch
S39	Crash switch (NO contact)

X3 - Emergency Stop

The emergency STOP control device is connected to a safety circuit with Performance Level c (Plc) according to ISO 13849-1.

Alternatively you can connect an emergency STOP control device as per EN 13850 or an evaluation unit for an anti-trap safety device.

- Install the product according to the manufacturer's instructions.

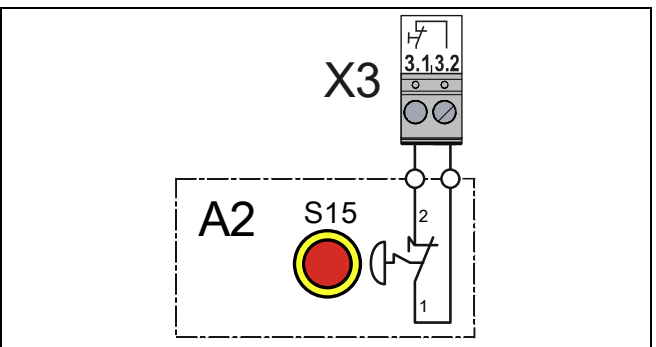

i NOTE

In the case of a drive unit with a frequency inverter, the door control can only be operated again 30 seconds after the emergency stop switch has been unlocked. Meanwhile, the gate control display flashes.

i NOTE

When activating the emergency stop switch fault indication *F 1.4* appears.

X4 - Switch for automatic closing

You can connect a switch for automatic closing time to terminals X4.1/4.2. With menu item 2.3, you select a time between 1 and 240 seconds after which the door closes automatically.

The switch activates and deactivates this function. The programmed time remains stored.

- Install the product according to the manufacturer's instructions.
- Activate automatic closing with menu item 2.3 after completion of the electrical installation.

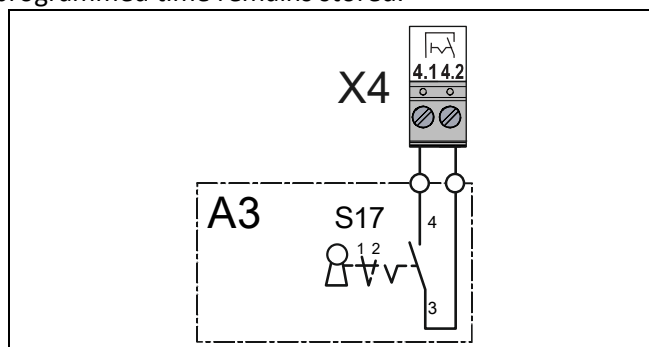

X5 - External control device

You can connect an external control device for operating the door to terminals X5.1 to X5.4. The control device loses its function when faults occur on the safety edge, light curtain or photocell.

- Install the product according to the manufacturer's instructions. Several examples of control devices are shown.

⚠ WARNING

Danger due to unattended door movement!

The safety devices are deactivated in operating mode hold-to-run. People or objects in the movement path are not detected.

- Install and operate the control device only with a clear view of the door.

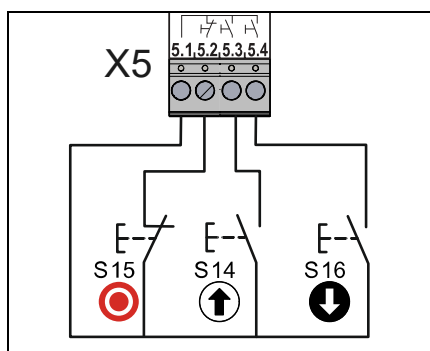

Triple pushbutton

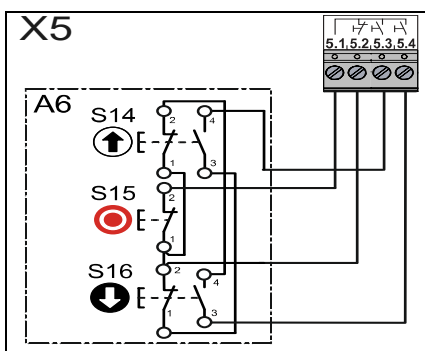

Triple pushbutton with command interlock

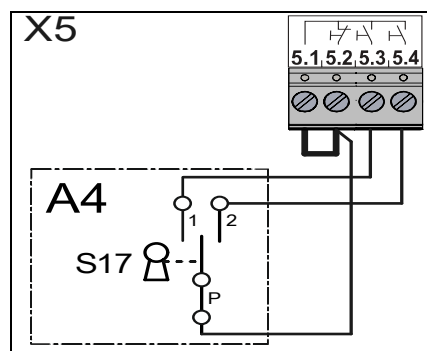

Key pushbutton

i NOTE

If you connect a control device without a STOP button to terminals X5, you need to install a jumper between X5.1/X5.2.

X6 - Photocell and light curtain

You can connect a light curtain or a reflective or through beam photocell to terminals X6.1/X6.2 as well as 24 V and GND.

- Mount the product according to the manufacturer's instructions.
- Various examples of photocells and light curtains are shown. Connect your product accordingly.
- After completion of the electrical installation, activate the product with menu item 0.1.
- You can select other functions of the photocell under menu item 2.4.

⚠ CAUTION

Injuries caused by uncontrolled movement or damage to property.

The controller does not detect defects on photocells or light curtains in blanking mode. Failure of the photocell or light curtain may result in injuries due to crushing, shearing or bumping.

- Use photocells and light curtains only in unblanking mode.

Photocells

A photocell is used for object protection and activated with operating modes 0.3 / 0.4. The photocell only switches in the final limit position OPEN and during CLOSE operation.

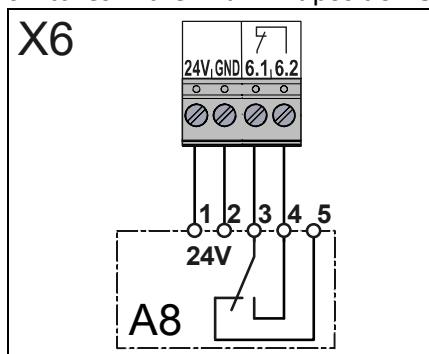

A8: Reflective photocell

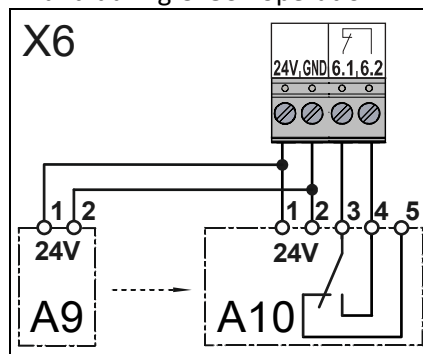

Through photocell
A9: Transmitter
A10: Receiver

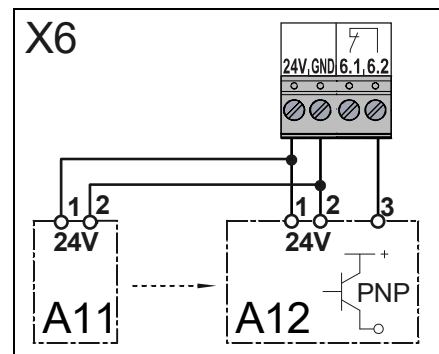

Through photocell
A11: Transmitter
A12: Receiver

i NOTE

When the photocell is activated, fault indication $F 2!$ appears.

Light curtain only with relay or semiconductor output

The light curtain must be self-testing and correspond at least to safety category 2 or performance level c (plc). If the light curtain corresponds to these requirements, the door can close into self-hold without safety edge system. For an operation without safety edge connect a resistor 8k2 via the terminals X2/3 and X2/4.

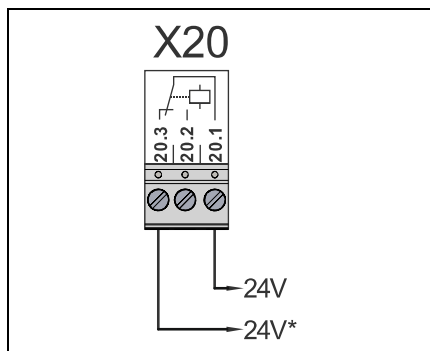

X20: Function relay
(Test light curtain)

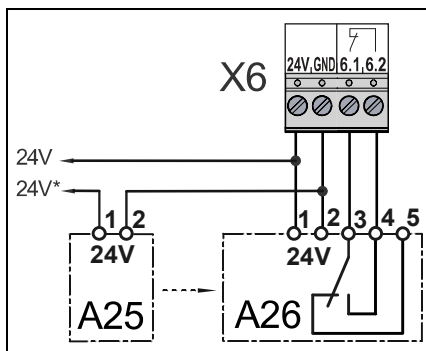

Light curtain
A25: Transmitter
A26: Receiver

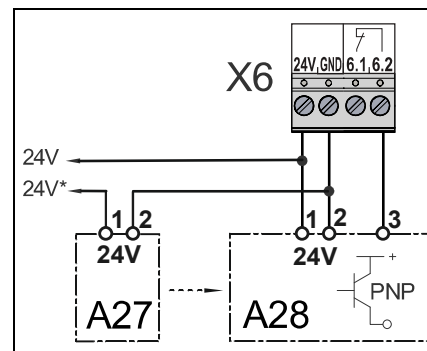

Light curtain
A27: Transmitter
A28: Receiver

To test the light curtain, activate relay contact X20. See programming point P 2.7. A testing is carried out with every CLOSE-command. Thereby the contact of the light curtain must switch off within 100 ms. If the test is positive, the contact must switch back on within 300 ms. If the test is negative, the fault indication F4.7 is displayed.

i NOTE

If the light beam is interrupted, fault indication F4.5 appears.

X7 - Radio receiver / pull switch

You can connect a pull switch or radio receiver to terminals X7.1/X7.2. The switching contact must be potential-free.

- Install the product according to the manufacturer's instructions.
- Activate the product after completion of the electrical installation with menu item 2.5.

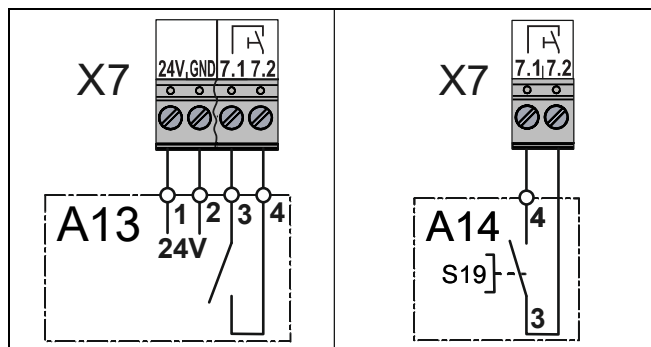

Radio receiver

Pull switch

X8 - Switch for intermediate open

You can connect a switch for intermediate open of the door to terminals X8.1/X8.2. The switch activates this function. With an OPEN command, the door moves to the saved door position. Only when you deactivate this function with the switch, the door will return to the final limit position OPEN.

- Mount the product according to the manufacturer's instructions.
- Activate the switch after completing the electrical installation using menu item I.5.

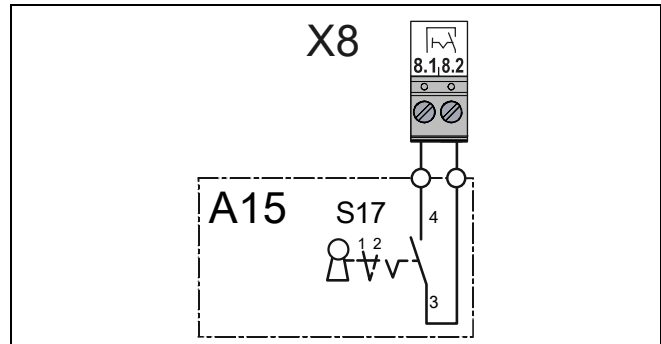

i NOTE

Use menu item 2.9 to specify the command devices for moving to intermediate open.

X20 - Relay contact for traffic lights, light curtain or magnetic brake

You can connect more external devices, such as traffic lights, to terminals X20.1-X20.3. X20 are potential-free relay contacts.

- Install the product according to the manufacturer's instructions.
- Connect the product as shown. You can connect traffic lights to terminals X20.1/ X20.2.
- Activate the product after completion of the electrical installation with menu items P 2.7.

NOTICE

Damage to components!

The maximum current at 230 V AC is 1 A and at 24 V DC 0.4 A. Exceeding these values may lead to the malfunctioning of the devices.

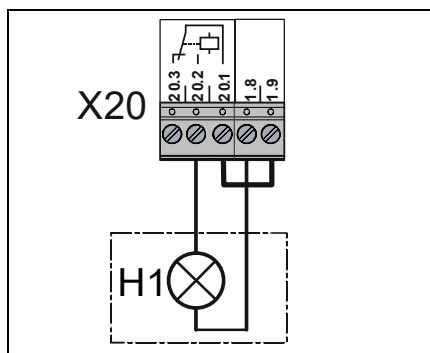

Traffic-light

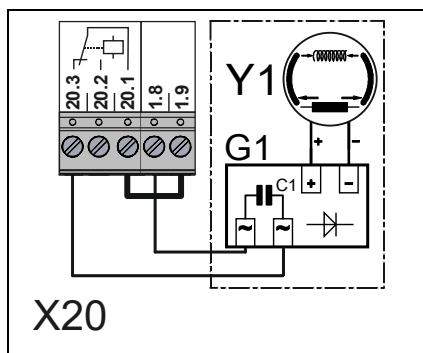

Magnetic brake
G1 Rectifier
Y1 Magnetic brake

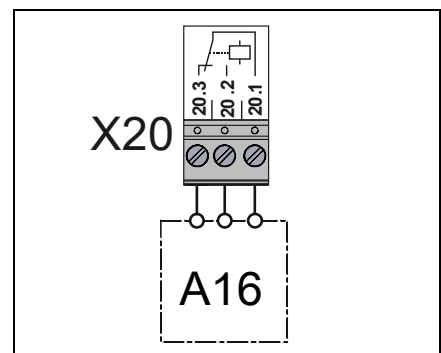

External devices

i NOTE

We recommend the use of LED trafficlights with 230 V.

8 Setting the final limit positions

The following explains how to set the final limit positions of the door at the initial commissioning.

i NOTE

You can correct the final limit positions later with menu items *P 1.1 - P 1.4*.

Setting the final limit positions - DES (digital limit switch)

If you have already connected a safety edge, the pre-limit is automatically set with the final limit positions.

1. Turn on power:

- Turn on the power using the main switch for the following steps.

2. Checking the output rotating direction:

- Press the OPEN button.
- If the door moves upwards, the output rotating direction is correct. Proceed with step 4.
- If the door moves downwards, change the output rotating direction. Proceed with step 3.

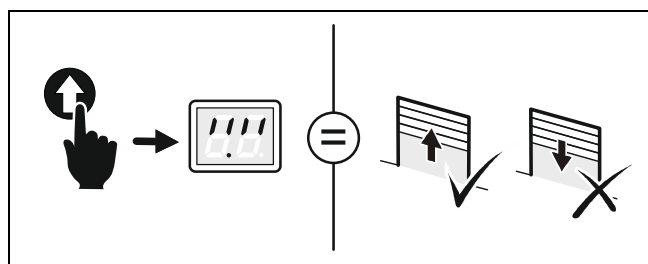

3. Changing the output rotating direction:

Carry out this step only if the door moves downwards after step 1.

- Press the OPEN and CLOSE buttons simultaneously for 3 seconds.
- The display changes as shown in the figure.

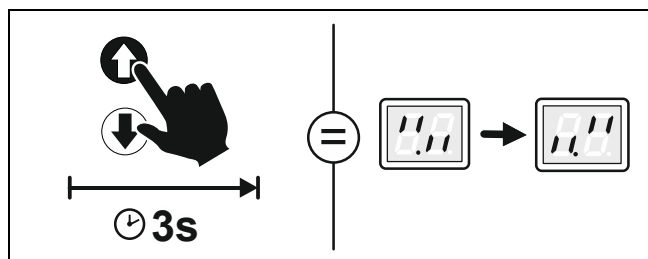

4. Setting the final limit position OPEN:

- Press the OPEN button until the door has reached the desired position. Press the button for at least 1 second.
- Save the final limit position OPEN by pressing the STOP button for 3 seconds.
- The display changes as shown in the figure.

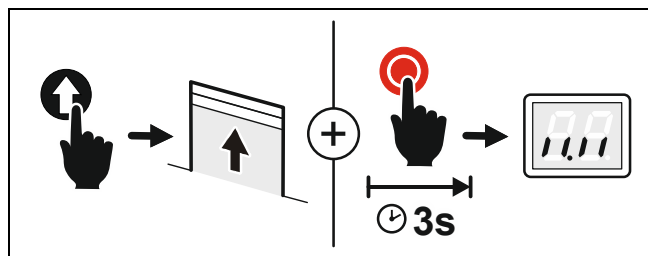

5. Setting the final limit position CLOSE:

- Press the CLOSE button until the door has reached the desired position. Press the Button for at least one second.
- Save the final limit position CLOSE by pressing the STOP button for 3 seconds.
- The display changes as shown in the figure.

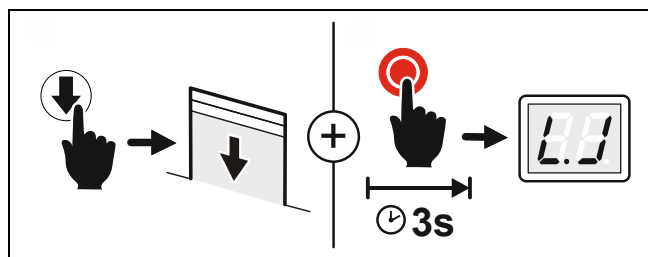

Setting the final limit position is complete. You can now operate the door in hold-to-run mode and program the door control.

Setting the final limit positions - NES (mechanical limit switches)

Please refer to the ELEKTROMATEN manual to set the final limit positions using mechanical limit switches.

9 Programming

i NOTE

Before you can start programming, you must have set the final limit positions.

Programming the door control

1. Start programming:

- Press the selector switch for 3 seconds. The display changes to 0.0.

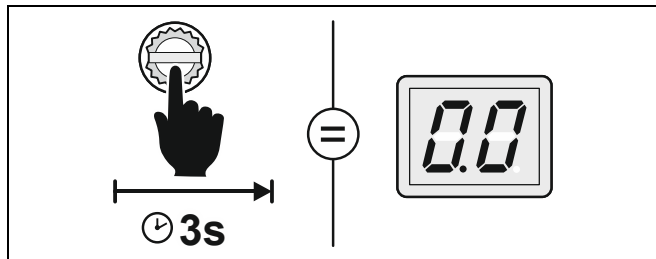

2. Select the menu item:

- Turn the selector switch to the desired menu item.
- Press the selector switch once to confirm the selection. This will take you to the options.

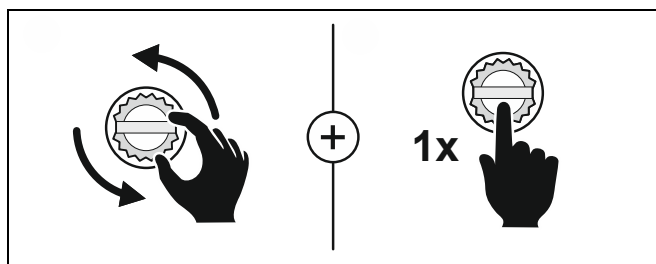

3. Selecting options:

- Turn the selector switch to the desired option.
- Press the selector switch once to save the selection. You will leave the options at the same time.

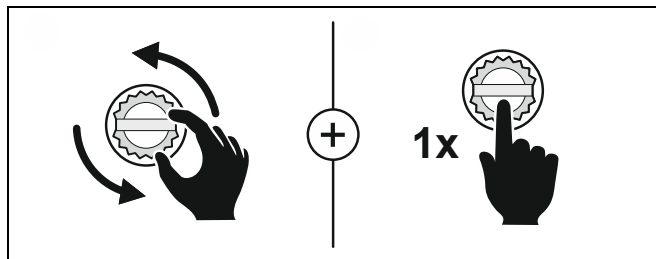

4. Terminate programming:

- Turn the selector switch to 0.0.
- Press the selector switch once to exit programming.

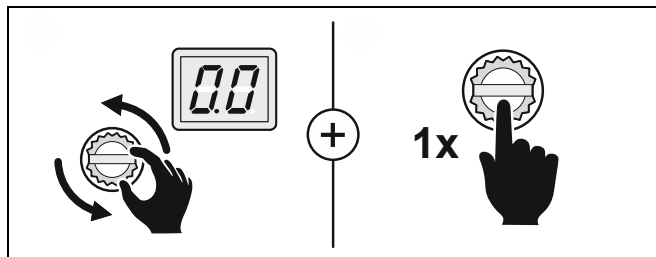

Explanation of the programming tables

①	0.3	② Auswahl Sicherheitseinrichtungen
③	④ .1	Spiralkabel oder WSD
	④ .2	Lichtgitter (nur für Lichtgitter mit OSE-Ausgang)
⑤	④ .3	Parallelbetrieb von Lichtgitter und WSD (Betrieb einer Sicherheitsschaltleiste an WSD nicht möglich)

- ① Number of the menu item
- ② Name of the menu item
- ③ Symbol for the factory setting
- ④ Number of the option
- ⑤ Name / description of the option

Menu items:

P 0.1 - Operating mode

With this menu item, you select the operating mode for moving the door during OPEN operation and CLOSE operation.

When selecting the option, note the following:

- the number of safety devices and safety edges at the door.
- the optional connection of a command device to terminals X5.

▲ WARNING

Danger due to unattended door movement!

The safety devices are deactivated in operating mode hold-to-run. People or objects in the movement path are not detected.

- Operate the door only with a clear view of the door.
- Options .5, provide additional safety; the safety devices remain active despite operating mode hold-to-run.

0.1	Operating mode
▶ .1	No safety device on door: hold-to-run OPEN/CLOSE
.2	No safety device on door: self-hold OPEN and hold-to-run CLOSE
.3	One safety device on door: self-hold OPEN/CLOSE
.4	One safety device on door: self-hold OPEN/CLOSE CLOSE operation is also possible in hold-to-run with a control device on X5
.6	One safety edge on door: hold-to-run OPEN/CLOSE. The safety edge is active during movement.

P 0.2 - Output rotating direction

Use this menu item to change the output rotation direction of the door drive unit.

0.2	Output rotating direction
	Select the options with the OPEN or CLOSE button
.0	Maintaining the output rotation direction. Exit the menu item by pressing the selector switch.
.1	Changing the output rotating direction. Save and exit the menu item by pressing the STOP button for 3 seconds .

P 1.1 / 1.2 - Coarse correction of final limit position

Use these menu items to modify the final limit positions of the door that have been already set.

1.1	Coarse correction of final limit position OPEN (DES)
1.2	Coarse correction of final limit position CLOSE (DES)
	<ul style="list-style-type: none"> ▪ Move to the desired door position using the OPEN or CLOSE button. ▪ Save the door position by pressing the STOP button once.

⚠ WARNING

Danger due to unattended door movement!

The safety devices are deactivated while adjusting.

- Block the door for pedestrians and vehicles.

P 1.3 – 1.5 - Fine correction of final limit positions

Use this menu item to modify the final limit positions of the door that have been already set. No door movement takes place during fine correction. Proceed step by step.

1.3	Fine correction of final limit position OPEN (DES)
1.4	Fine correction of final limit position CLOSE (DES)
1.5	Fine correction of the safety edge's pre-limit (DES)
-9	Correction in direction of final limit position CLOSE
-.9	Correction in direction of final limit position OPEN

i NOTE

Use menu item *P 2.1* to activate or deactivate the safety edge in the pre-limit area.

P 1.6 - Door positions for intermediate open

Use this menu item to set the door position for intermediate open. Intermediate open is a door position between final limit positions OPEN and CLOSE. This requires the connection of an external switch to the two terminals of connector X8. Use this switch to activate and deactivate the movement to intermediate open. This function is only available in combination with an ELEKTROMATEN having a digital limit switch. Use menu item 2.9 to specify the command devices for moving to the position.

1.6

Setting the door positions for intermediate open

- Move to the desired door position using the OPEN or CLOSE button.
- Save the door position by pressing the STOP button once.

▲ WARNING

Danger due to uncontrolled movements

During the setting, the safety devices on the door are without function.

- Lock the door for pedestrians and vehicles.

P 1.7 - Switching position of relay X20

You only have to teach-in this switching position if you want to use the options 1/2 or 1/1 of menu item 2.7. With this menu item you can set the door position in which relay X20 switches. To use this function, you must set menu item P 2.7 and connect a device to X20. This menu item is only available in combination with an ELEKTROMATEN with a digital limit switch.

▲ WARNING

Danger due to unattended door movement!

The safety devices are deactivated while adjusting.

- Block the door for pedestrians and vehicles.

1.7

Setting the switching position of relay X20

- Move to the desired door position using the OPEN or CLOSE button.
- Save the door position by pressing the STOP button once.

P 2.1 - Safety edge in pre-limit area

Use this menu item to activate or deactivate the safety edge in the pre-limit area.

2.1	Function of the safety edge system in the pre-limit area
▶.1	Safety edge active
.2	Safety edge is inactive (e.g. with a non-contact photocell)
.3	Ground adjustment (DES)
.4	Reversing in overrun area (DES)

Ground adjustment

With the ground adjustment, the final limit position CLOSE can be adjusted automatically in the range of 2 - 5 cm to compensate for rope stretches or changes of ground. The safety edge is activated when it contacts the ground. The final limit position CLOSE will be corrected with the next close.

- Only with digital limit switch (DES)
- Do not use with overrun correction
- Do not use with pressure-wave switch or light curtain.

Reversing in the overrun area

Function for maintaining the operating forces in the pre-limit area

- At high speeds
- Only with digital limit switch (DES)
- The function is not necessary for frequency inverter drive units with frequency inverter

P 2.2 - Overrun correction

Automatic limit switch correction to achieve a constant CLOSE position.

This menu item is only available in combination with an ELEKTROMATEN having a digital limit switch.

2.2	Overrun correction (DES)
▶.0	Off
.1	On (do not use with P 2.1 ground adjustment)

P 2.3 - Automatic closing

With this menu item, you can select a time between 1 and 240 seconds after which the door closes automatically. You can connect a switch for activating and deactivating this function to terminals X4.1 and X4.2. The programmed time remains stored.

2.3	Automatic closing
▶.0	Deactivated
.1 - 2.40	.1 = 1 second up to 9.9 = 99 seconds For more than 99 seconds, the display will flash twice to show 3-digit numbers in full: 1.- and 0.0 = 100 seconds up to 1.- and 9.9 = 199 seconds 2.- and 0.0 = 200 seconds up to 2.- and 4.0 = 240 seconds

You can interrupt automatic closing manually:

- Press the STOP button when the door is in final limit position OPEN. The door remains open.
- Press the OPEN button to reactivate automatic closing timer.

i NOTE

With menu item 2.4 you can set whether activation of a photocell interrupts automatic closing.

P 2.4 - Reaction of automatic closing to photocell / light curtain

Use this menu item to stop automatic closing when the photocell is activated. This requires a photocell and activation of menu item 2.3. In operating mode (0.1) hold-to-run, this menu item has no effect.

2.4	Reaction of automatic closing to photocell / light curtain
▶.0	Deactivated
.1	Stopping of automatic closing 2.3 <ul style="list-style-type: none"> ▪ The door closes 3 seconds after the interruption of the photocell / light curtain has ended.
.2	People and vessel recognition <ul style="list-style-type: none"> ▪ If the interruption of the photocell lasts less than 1.5 seconds (e.g. a person passes the door), the door closes after the time specified in 2.3. ▪ If the interruption of the photocell lasts longer than 1.5 seconds (e.g. a vehicle passes the door), the door closes after 3 seconds.

i NOTE

If the light beam is interrupted, fault indication F 2.1 appears.

P 2.5 - Limiting reversals

Activate this menu item only if automatic closing 2.3 is enabled. When automatic closing is enabled, the door moves to final limit position CLOSED after the set time. The door reverses when hitting an obstacle during movement. This means that the door changes the direction of movement and moves to the final limit position OPEN. Thanks to automatic closing, the door tries to close again after the set time has elapsed. This will continue until the obstacle is removed.

To prevent continuous opening and closing in this situation, you can specify a maximum number of successive reversals. When the specified number has been reached, the door stops in final limit position OPEN.

i NOTE

When the door exceeds the set number of reversals, fault indication F 2.2 appears.

2.5	Limiting reversals
.0	Deactivated
.1 - 1.0	Adjustable from 1 to 10. .1 = 1 reversal 1.0 = 10 reversals ► Factory setting : .2

P 2.6 - Radio and pull switch functions

First, connect a radio or pull switch to terminals X7.

Use this menu item to select how the door responds to a command from the radio or pull switch button.

i NOTE

If you activate option .3 and automatic closing 2.3, the door closes after the time set in 2.3 when you press the pushbutton.

2.6	Radio and pull switch functions
► .1	Activation in final limit position OPEN or intermediate open: door moves in final limit position CLOSE Activation in final limit position CLOSE or other: door moves in final limit position OPEN
.2	Activation in final limit position CLOSE or intermediate open: door moves in final limit position OPEN Activation in final limit position OPEN or intermediate open: door moves in final limit position CLOSE Further activation during movement take place in the following order: OPEN-operation - STOP - CLOSE-operation - STOP - OPEN-operation
.3	Activation from all positions: door moves in final limit position OPEN

P 2.7 - Relay functions of X20

Use menu item *z7* to control the function of X20. X20 is a potential-free relay contact.

2.7	Relay functions of X20
▶ .0	Deactivated
.1	Impulse of 1 second during OPEN operation at switching position Switching position requires teach-in with <i>l.7</i>
.2	Permanent contact from switching position. Switching position requires teach-in with <i>l.7</i>
.3	Red light: permanent contact during door movement In final limit position OPEN: flashing for 3 seconds In final limit position CLOSE: flashing for 3 seconds
.4	Red light: permanent contact during door movement In final limit position OPEN: flashing for 3 seconds In final limit position CLOSE: off
.5	Flashing light: permanent contact during door movement. In final limit position OPEN: lights up for 3 seconds In final limit position CLOSE: lights up for 3 seconds
.6	Flashing light: permanent contact during door movement In final limit position OPEN: lights up for 3 seconds In final limit position CLOSE: off
.7	Green light: off during door movement In final limit position OPEN: permanent contact In final limit position CLOSE: off Instead of green light, for example: usable for the clearance of a dock leveler
.8	In final limit position CLOSE: permanent contact
1.0	Impulse of 1 second with OPEN command
1.1	Impulse when switching position is exceeded. Permanent contact when stopping in switching position. Switching position requires teach-in with <i>P l.7</i>
1.2	Brake control Active during operation Inactive at stop
1.4	Light curtain test, etc. Test prior to each closing operation

P 2.9 - Specifying control device for intermediate open

Use this menu item to specify the control devices for approaching intermediate open. You must first set a position for intermediate open with menu item *!5*. To switch intermediate open off and on, a switch must be installed on X8.

You can connect further control devices for intermediate open to X7 or X5. If an OPEN command is issued using the activated control devices, the door moves into intermediate open.

2.9	Specifying control device for intermediate open
▶ .1	Intermediate open is possible with all control devices.
.2	Intermediate open using a control device on X7. Final limit position OPEN with OPEN button of the door control and control device on X5.
.3	Intermediate open with OPEN button of the door control and control device on X5. Final limit position OPEN with control device on X7.

i NOTE

For options **.2** and **.3**, an OPEN command has priority over an intermediate open command, regardless of the order in which the commands were executed.

P 3.1 - Force monitoring of sectional doors

Activate this menu item only if you operate a sectional door with counter-balancing and digital limit switch (DES). Force monitoring detects whether the door also lifts people. Force monitoring is active from an opening width of approx. 0,05 m to 2 m. Slowly advancing changes, such as decreasing spring tension, are compensated automatically.

During force monitoring, the door control measures the speed of the door movement. If the current door movement is slower than the previous one by more than the percentage specified, force monitoring triggers and stops the door. Afterwards, the operating mode hold-to-run is active and error message *F 4!* appears. In the case of severe temperature changes or high wind loads, force monitoring may trigger unintentionally.

▲ WARNING

Danger to life and risk of serious injuries by entanglement

This function is only a supplement to safety measures against entanglement.

- Install a pull-in protection

3.1	Force monitoring of sectional doors (DES)
▶ .0	Deactivated
.2 - 1.0	Selectable is a speed difference from 2% to 10%.

Teaching-in of the function

- After exiting programming, you need to move the door once in self-hold to final limit position OPEN and final limit position CLOSED.

i NOTE

You cannot select force monitoring in combination with operating mode hold-to-run.

P 3.2 - Interruption of the photocell

The function is only available for door drive units with digital limit switch (DES).

Components on the door (e.g. spiral cables) may interrupt the photocell always in the same position. A fault indication appears. Use this menu item for setting the position. During CLOSE operation, the photocell will be deactivated from this position onwards. A fault indication no longer appears for this position.

As soon as you save option **.1** and exit programming, teach-in mode is active.

3.2	Interruption of the photocell
▶.0	Deactivated
.1	Activated Set a reference position



NOTICE

Impairment of product functionality

There is no object protection when setting this function!

- Set the reference position before proceeding.

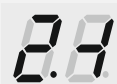
Setting of the function

1. Drive the door to final limit switch position CLOSE.	
2. After leaving programming, teach-in mode is active. The display changes as shown in the figure.	
3. Open and close the door until the light beam has been interrupted twice in the same door position. The display changes as shown in figure if the first interruption is successful.	
4. The reference position is stored after two consecutive interruptions of the photocell. The display changes as shown in the figure.	

P 3.3 - Travel time monitoring

This function is only available for ELEKTROMATEN with mechanical limit switches. The set travel time is automatically compared with the time measured between the final limit positions. When exceeding the running time, fault indication **F 5.5** appears. The fault indication is reset by closing the door.

3.3	Travel time monitoring
.0	Off
.1 - 9.0	1 to 90 seconds ▶ Factory setting to 90 seconds

i NOTE

Recommended setting: travel time + 7 seconds

P 3.4 - Door safety switch

The door safety switch is connected to input X2.2.

3.4	Door safety switch
▶ .1	Slack-rope switch / Pass-door switch
.2	Crash switch as NC contact After activation: "Hold-to-run" door operating mode
.3	Crash switch as NO contact After activation: "Hold-to-run" door operating mode
.4	Crash switch as NC contact After activation: Reversing in OPEN final limit position. Reset after contact reset otherwise "Hold-to-run" door operating mode
.5	Crash switch as NO contact After activation: Reversing in OPEN final limit position. Reset after contact reset otherwise "Hold-to-run" door operating mode

i NOTE

If you are using a WSD door module, only options .1; .2 and .4 available.

P 3.8 - Shorten/lengthen the reversing time

Use this menu item to shorten or lengthen the reversing time when a safety device is activated.

Reversing time is the time it takes for the door to switch from CLOSE operation to OPEN operation.

Lengthening the reversing time protects the door mechanism. Shortening the reversing time reduces the closing forces at the safety edge. You can set the reversal time in steps from .1 to .3.

3.8	Shorten/lengthen the reversing time
▶ -.0	Deactivated
-.1 - -.3	-.1 = Shorten the reversing time. -.3 = Lengthen the reversing time.

P 4.1 – 4.9 - Frequency inverter functions

The following menu items are only visible and applicable if the door drive unit is equipped with a mounted frequency inverter.

Increasing / decreasing the output speed

Use this menu item to change the output speed of the door drive unit equipped with a frequency inverter. With menu item 4.3 you can additionally increase the closing output speed from a height of 2.5 m onwards. To do this, you must first define the switching position for the higher output speed CLOSE with menu item 4.4.

i NOTE

The adjustable values 4.1 to 4.3 depend on the door drive unit. You can find the values in Chapter „technical data“ in the installation instructions for the door drive unit. The value is displayed in rpm of the output shaft.

4.1	Increase/decrease output speed OPEN
4.2	Increase/decrease output speed CLOSE
4.3	Increase/decrease output speed CLOSE > 2,5 m
	Possible values depend on the door drive unit.
4.4	Setting the reference position for increased output speed CLOSE
	<ul style="list-style-type: none"> Move to the desired door position using the OPEN or CLOSE button. The position must be at a height at least 2,5 m. Save the door position by pressing the STOP button once.

Acceleration to output speed OPEN/CLOSE

With menu items 4.5 and 4.6, you increase/decrease the time required by the door drive unit for accelerating to the specified output speed (4.1 - 4.3).

4.5	Increase / decrease acceleration OPEN
4.6	Increase / decrease acceleration CLOSE
0.5 - 3.0	0.5 = Highest acceleration. 3.0 = Lowest acceleration (time in seconds).

Braking

With menu items 4.7 and 4.8, you increase/decrease the time required by the door drive unit for slowing to the specified crawling speed 4.9.

4.7	Increase/decrease brake deceleration OPEN
4.8	Increase/decrease brake deceleration CLOSE
0.5 - 3.0	0.5 = Highest brake deceleration. 3.0 = Lowest brake deceleration (time in seconds).

With menu item 4.9, you increase/decrease the crawling speed in steps. The door drive unit moves at the crawling speed shortly before reaching the final limit position to precisely approach the cut-off point of the final limit position.

4.9	Increasing/decreasing crawling speed OPEN and CLOSE
	Possible values depend on the door drive unit.

P 8.5 - Setting the maintenance cycle counter

With these menu items, you set a reminder for the maintenance of the door. The maintenance cycle can be set between 1,000 and 99,000 cycles. The counter decreases by 1 every time the door reaches the final limit position OPEN. When the counter reaches the value 0, the setting from menu item 8.5 is activated.

8.5	Setting the maintenance cycle counter
▶.0	Deactivated.
.1 - 9.9	Activated. Counting down from .1 = 1,000 cycles to 9.9 = 99,000 cycles.

P 8.6 - Response after expiry of the maintenance cycle counter

8.6	Response after expiry of the maintenance cycle counter
▶.1	Display shows C.S. alternating with the value specified in 8.5
.2	Operating mode change to hold-to-run. Display shows C.S. alternating with the value specified in 8.5.
.3	Operating mode change to hold-to-run. Display shows C.S. alternating with the value specified in 8.5. Option: Press the STOP button for 3 seconds to ignore the message for 500 cycles.
.4	Display shows C.S. alternating with the value specified in 8.5. Relay contact X21 switches.

i NOTE

You can delete the response from menu item 8.6 by setting a new value with menu item 8.5.

P 9.1 - Readout of cycle counter

With this menu item, you can read out the cycle counter of the door control. The counter increases by 1 every time the door reaches the final limit position OPEN. It is not possible to reset the cycle counter.

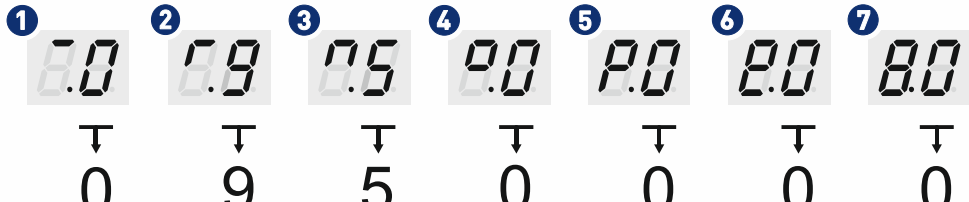
9.1	Readout of cycle counter
	After selecting the menu item, the display changes 7 times to show a 7-digit number. The left side of the two-digit display shows a symbol for the current position of cycle counter. The right side shows the number of the current position. The example below shows 950.000 cycles.
	

P 9.2 - Readout of fault indications

With this menu item, you can read out the last 6 fault indications of the door control. After selecting the menu item, the display changes and shows the last six fault indications. First an *F* is shown, then the number of the fault indication. The first fault indication displayed is the most recent.

9.2	Readout of fault indications
	The display changes and shows the last 6 fault indications.

i NOTE

An error that occurs several times in a row is only saved once as long as no other error has occurred in the meantime.

P 9.3 - Readout of the cycle counter since last programming change

This menu item shows the number of cycles the door has run since the last programming change. The counter increases by 1 every time the door reaches the final limit position OPEN.

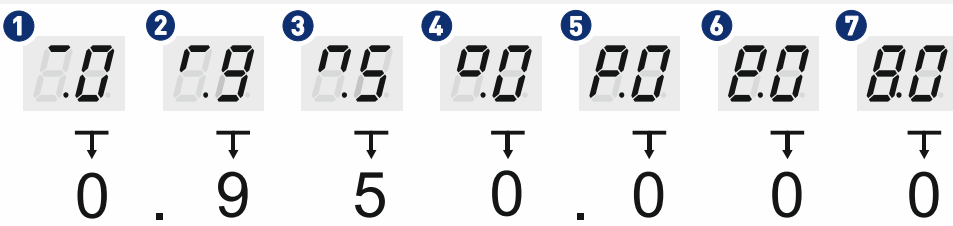
9.3	Readout of the cycle counter since last programming change
	After selecting the menu item, the display changes 7 times to show a 7-digit number. The left side of the two-digit display shows a symbol for the current position of cycle counter. The right side shows the number of the current position. The example below shows 950.000 cycles.
	
▶ .1	Cycle counter of the last change in programming
.2	Number of activations of slack-rope, pass-door and crash switch

P 9.4 - Readout software version

This menu item displays the software version of the door control. For drive units with GfA frequency inverter, the software version of the motor is shown as well.

9.4	Readout software version
	The display changes and shows the number of the software version.

P 9.5 - Reset to factory settings / use of GfA-Stick

Activate the GfA-Stick with option .0. The GfA-Stick (part no. 20003696) allows readout of faults, operations, and programming by using the GfA App. With option .1, you delete all set menu items and reset the door control to factory setting.

9.5	Reset to factory settings / use of GfA-Stick
.0	Activate GfA-Stick.
.1	Reset to factory settings. <ul style="list-style-type: none"> ▪ Press the OPEN Button once to select menu item . 1. ▪ Confirm your selection by pressing the STOP Button for 3 seconds.

10 Fault correction

i NOTE

You can find detailed information on faults and how to rectify them in our fault guide for door controls.

- Download the fault guide from the GfA-Portal.
- Start the fault guide using the GfA+ app.

Fault indications

Door control is off / display is dark

	Possible causes	Fault correction
Display is dark / door control is without function	No input function	Measure the input voltage.
	Overload	Check whether too many electrical loads are connected to the control circuit (24 V).
	Short circuit	Check whether a faulty device is connected to the control circuit (24 V).
	Water damage	Check if water has entered the control box.
	A different defect	Disconnect all lines (delivery status). Replace the door control if the display stays dark.

Fault in the safety circuit

	Cause of the fault	Fault correction
F.	Display alternates between <i>F</i> and number	
1.2	Slack-rope switch / pass-door contact is open.	<p>Check the connecting cables for breaks.</p> <p>Check whether the spiral cable or WSD door module is connected correctly.</p> <p>Slack-rope switch: check if the ropes are taut.</p> <p>Check the DIP switch position in the door leaf box.</p> <p>Measure the slack-rope switch / pass-door contact.</p>

	Cause of the fault	Fault correction
F.	Display alternates between <i>F</i> and number	
1.3	<p>Safety circuit is open.</p> <p>Emergency manual operation is activated.</p> <p>Thermal protection of the motor has tripped.</p> <p>The restart protection has tripped.</p>	<p>Check the door drive unit for overload or stalling</p> <p>WARNING! Danger of the door dropping! Do not release stalling when using a door drive unit with a safety brake! Stalling may indicate a catch incident. Replace the door drive unit.</p> <p>Allow the door drive unit to cool.</p> <p>Check manual emergency operation.</p> <p>Check plugs and terminals for firm seating.</p> <p>Doors with separate safety brake: check the safety brakes.</p>
1.4	The emergency stop button is pressed.	<p>Check Emergency stop switch.</p> <p>Check connection cable for disconnection.</p>
1.7	Slack-rope / or pass-door contact is faulty.	<p>Open and close pass door.</p> <p>Check the pass-door installation.</p> <p>Set the switching distance to <4 mm.</p> <p>Check the DIP switch position in the door leaf box.</p> <p>Check the resistance and wiring of the spiral cable.</p> <p>Check the control voltage for overload.</p>
1.8	Line cross-circuit in the slack-rope / pass-door circuit	<p>Check the DIP switch position in the door leaf box.</p> <p>Check whether the 5K0 resistor is installed in the door leaf box.</p> <p>Check whether the 5K0 resistor in the door leaf box is connected in series.</p> <p>Check the wiring of the spiral cable.</p>

Faults of safety devices

	Cause of the fault	Fault correction
F.	Display alternates between <i>F</i> and number	
2.0	No safety edge detected.	<p>Check the wiring and condition of the safety edge.</p> <p>Check the DIP switch position in the door leaf box.</p> <p>Check the condition of the safety edge visually and electrically.</p>
2.1	Photocell activated.	<p>Check the condition and alignment of the photocell.</p> <p>Remove obstacles from door area.</p> <p>Clean the photocell and the reflector.</p> <p>Check the connection cable for breaks.</p> <p>Replace photocell if necessary.</p>
2.2	Maximum reversing number reached by actuating the safety edge (only with automatic closing).	<p>Remove obstacles from door area.</p> <p>Check the door mechanism for damage. Check the run of the door in the CLOSE direction.</p> <p>Check whether the safety edge system is correctly functioning.</p> <p>Reset or deactivate menu item <i>P 2.5</i>.</p>
2.4	Safety edge 8k2 is actuated.	<p>Check the safety edge and door leaf boxes for water damage.</p> <p>Check the safety edge visually and electrically.</p>
2.5	Safety edge 8k2 is faulty.	<p>Measure the spiral cable and the safety edge electrically.</p> <p>Check all connection points and pin-and-socket connectors for firm seating.</p>

Faults of safety devices

	Cause of the fault	Fault correction
F.	Display alternates between <i>F</i> and number	
2.6	Safety edge 1k2 is actuated.	<p>Check the pressure-wave switch.</p> <p>Check the sensitivity setting of the pressure-wave switch.</p> <p>Check the spiral cable for mechanical damage and measure it electrically.</p> <p>Check all connection points and pin-and-socket connectors for firm seating.</p>
2.7	Safety edge 1k2 is faulty.	<p>Measure the spiral cable electrically.</p> <p>Check the safety edge and door leaf boxes for water damage.</p>
2.8	Safety edge 1k2 - testing is negative.	<p>Check the setting of the pre-limit.</p> <p>Check the pressure-wave switch.</p> <p>Check the safety edge for damage.</p> <p>Check whether the safety edge is compressed in final limit position CLOSE.</p>
2.9	The optical safety edge is actuated or faulty.	<p>Check whether the rubber profile is squashed.</p> <p>Check transmitter and receiver by replacing them.</p> <p>Check alignment and mechanics.</p> <p>Check the safety edge and door leaf boxes for water damage.</p>

Fault at limit switch

	Cause of the fault	Fault correction
F.	Display alternates between F and number	
3.1	The contact of the emergency manual operation is open or faulty.	Check if the emergency manual operation is activated. Measure the contact of the emergency manual operation electrically.
	The connection cable is faulty.	Check the connection cable for damage. Check plugs for firm seating.
	The thermal contact was activated. The restart protection has tripped.	The drive unit experiences an overload. Check the condition of the door (damage, spring fracture, etc.). Warning! Danger of the door dropping! Stalling may indicate a triggered safety brake. Take appropriate measures. Allow the drive unit to cool. If there is no continuity after cooling, the thermal contact is defective.
	An emergency limit switch has been reached or actuated.	Check whether the drive unit was moved into the emergency limit switch range with the emergency manual operation. Check whether the overrun of the drive unit is too long.
	The limit switch system has been changed from DES to NES.	Check whether the limit switch system has been changed. Reset the door control.
3.2	The emergency limit switch range CLOSE has been reached.	Check whether the drive unit was moved into the emergency limit switch range with the emergency manual operation. Check whether the overrun of the drive unit is too long.
3.4	Incorrect actuation of the pre-limit S5. The pre-limit is not connected, wired incorrectly or faulty.	Check whether a pre-limit is present. Check the wiring. Check the connection cable visually and electrically.
3.5	No limit switch detected (Note: active at initial operation)	Check the connection cable visually and electrically. Check all plugs for firm seating. For TS 970 and TS 959: check the position of the transformer bridge (terminals X 1.5 to X 1.7). Note the supply voltage on site and the chapter "Electrical installation". For TS 970 and TS 971 with NES: Unlock the EMERGENCY STOP command device. Insert a wire link between terminals X 3.1 and X 3.2.

	Cause of the fault	Fault correction
F.	Display alternates between <i>F</i> and number	
3.6	Incorrect detection of the limit switch system. The limit switch system was changed from DES to NES without resetting the door control.	Check whether the limit switch system has been changed. Reset the door control.

Internal faults of the door control / force monitoring

	Cause of the fault	Fault correction
F.	Display alternates between <i>F</i> and number	
3.7	Internal plausibility error. The mains supply of the door control is incorrect. The voltage fluctuates.	Measure the input voltage. Check the fuses of the supply line. Establish a stable power supply. Measure the voltage under load. Measure the voltage at the motor connector. Establish a stable power supply. Check the connection cable and the plug for firm seating.
3.8	The temperature in the door control is too high.	Measure the ambient temperature and compare it with the permitted temperature range of the door control. Cool the door control by shutting it down.
4.1	Force monitoring triggered.	Check the door mechanism for damage. Check whether a wind load acts on the door. Check the spring tension.
4.5	The crash switch was activated, is defective or not programmed	Check the door curtain for impact damage. Check the crash switch. Check the setting of menu item 3.4. To reset the fault, press the STOP button and hold for 3 seconds.
4.6	Light curtain was activated.	Remove obstacles from door area. Correct the alignment of the light curtain. Clean the optics of the light curtain.
4.7	Testing of the light curtain was unsuccessful. The light curtain is wired incorrectly, incompatible or defective.	Check the wiring of the light curtain. Check the function of the light curtain.

	Cause of the fault	Fault correction
F.	Display alternates between F and number	
5.0	Fault of the controller.	Switch the door control off and on. Replace the door control if necessary.
5.1	ROM fault.	Switch the door control off and on. Replace the door control if necessary.
5.2	CPU fault.	Switch the door control off and on. Replace the door control if necessary.
5.3	RAM fault.	Switch the door control off and on. Replace the door control if necessary.
5.4	Internal fault. Fault 3.7 was detected five times in a row.	See fault 3.7. Switch the door control off and on. Replace the door control if necessary.

Fault of door movement

	Cause of the fault	Fault correction
F.	Display alternates between <i>F</i> and number	
5.5	Fault of digital limit switch (DES).	<p>Check the limit switch plug for firm seating.</p> <p>Check the connection cable visually for damage.</p> <p>Check the limit switch by replacing it with a properly functioning DES.</p>
5.6	<p>Fault in door movement.</p> <p>The door mechanism is stiff or blocked.</p>	<p>Check door drive unit for stalling.</p> <p>WARNING! Danger of the door dropping! Do not release stalling when using a door drive unit with a safety brake! Stalling may indicate a catch incident. Replace the door drive unit.</p> <p>Check the door mechanism for damage.</p>
	The final limit position OPEN/CLOSE is not reached.	Check final limit position OPEN/CLOSE. When the door hits a cushion, then correct the final limit position.
	A supply phase is missing.	Check the mains supply of the door control. Establish the correct power supply.
	Brake does not release.	Check the brake and rectifier.
	The limit switch is not driven.	Check the limit switch turn while the door is moving.
<p>The running time is set incorrectly.</p> <p>Only for FI-drive: frequency inverter is not detected.</p>	<p>Check and correct the voltage supply of the door control.</p> <p>Correct the running time (menu item 3.3)</p> <p>For single-phase FI drives: Check neutral on the mains supply. Check the transformer bridge at the AC power connector of the door control.</p>	
5.7	The rotating field of the supply network has changed.	Establish a clockwise rotating field at the mains supply.
5.8	Incorrect door movement from idle state.	<p>Drive units with brake release: Check whether the brake release lever has been activated.</p> <p>Warning! Danger of the door dropping! Only qualified personnel may operate the brake release. Follow the instructions for the drive unit.</p>
		<p>Drive units with gear release: Check whether the gearbox is released and the door has been moved by hand. Engage the gearbox and switch the door control off and on.</p>
		Drive units with magnetic brake: brake without function. Check whether the brake is supplied with voltage.
5.9	The door drive unit does not follow the given travel direction.	<p>The brake does not hold the door: check the brake and rectifier for defects, wear or moisture damage.</p> <p>Measure the voltage at the motor plug and check its firm seating. Check the screws on the motor connection.</p>

Fault on the frequency converter

These fault indications appear only for door drive units with a frequency inverter.

	Cause of the fault	Fault correction
F.	Display alternates between <i>F</i> and number	
6.1	The closing speed is too high.	Check the door mechanism for stiffness. Only for doors with counter-balancing: check for spring fracture. Replace door drive unit if necessary.
6.2	Internal communication fault of frequency inverter.	Switch the door control off and on. Check connection cable to limit switch. Check the connection cable and the plug for firm seating. Replace door drive unit if necessary.
6.3	Low voltage in the DC voltage link.	Measure the voltage during door movement. Check mains supply. Change ramp times / speeds. (P 4.1-P 4.9)
6.4	Excess voltage in DC voltage link.	Measure the voltage during door movement. Check mains supply. Change ramp times / speeds. (P 4.1-P 4.9)
6.5	Temperature limit exceeded.	Door drive unit overloaded. Check for excessive ambient temperature. Allow door drive unit to cool and reduce number of cycles.
6.6	Permanent current overload.	Door drive unit overloaded. Check the door mechanism for stiffness.
6.7	Fault of brake / frequency inverter	Check the brake. Replace door drive unit if necessary.
6.9	Collective indication for frequency inverter	Switch the door control off and on. Replace door drive unit if necessary.

Faults when setting the final limit positions

	Cause of the fault	Fault correction
F.	Display alternates between <i>F</i> and number	
8.1	When setting the final limit positions, the travel distance was smaller than the smallest possible.	When resetting the final limit positions, move the door for at least one second before storing the position. Reset door control to factory setting (P 9.5). Notice! All settings will be lost!

11 Maintenance

WARNING

Danger to life from electric shock!

Improper maintenance may result in fatal injury from electrical current.

- Disconnect all cables from the power supply.
- Only allow competent personnel or electricians to carry out the maintenance.
- Secure the mains disconnecter against being switched on or plugged in again.

The electronic components of the door control are maintenance-free. Carry out the following maintenance operations at least once a year:

Component	Procedure
Housing	Use a dry cloth to remove dust and light dirt.
Connecting cables	Check the connecting cables for firm seating and possible damage (e.g. to the insulation). Replace damaged cables.
Fasteners	Check the fasteners for firm seating and damage. Replace damaged parts.
Gaskets	Replace any porous gaskets.
Cable glands	Check the cable glands for firm seating and leak-tightness. Replace damaged cable glands.

12 Disposal

Dispose of packaging

Dispose of the packaging material properly according to the local legal regulations or recycle it.

Dispose of old devices

Dispose of old devices properly according to local legal regulations. Return old devices to the return and collection systems available. You can also return GfA products free of charge. Please apply enough postage to the package and mark it as "old devices".

NOTICE

Environmental damage!

The gearbox contains oil.

- Ensure proper disposal according to local legal regulations.

i NOTE



Old devices marked with the adjacent symbol must not be disposed of with unsorted municipal waste.

Declaration of incorporation

within the meaning of Machinery Directive 2006/42/EC
for partly completed machinery, Appendix II Part B



Declaration of conformity

within the meaning of EMC Directive 2014/30/EU
within the meaning of RoHS Directive 2011/65/EU

GfA ELEKTROMATEN GmbH & Co. KG
Wiesenstraße 81 · 40549 Düsseldorf
Germany

We,
GfA ELEKTROMATEN GmbH & Co. KG
declare under our sole responsibility that the
following product complies with the above
directives and is only intended for installation in a
door system.

Door control
TS970

We undertake to transmit in response to a
reasoned request by the appropriate regulatory
authorities the special documents on the partly
completed machinery.

This product must only be put into operation
when it has been determined that the complete
machine/system in which it has been installed
complies with the provisions of the abovementioned
directives.

Authorised representative to compile the
technical documents is the undersigned.

Düsseldorf, 01.05.2023

Stephan Kleine
CEO

Signature

The following requirements from Appendix I of
the Machinery Directive 2006/42/EC are met:

1.1.2, 1.1.3, 1.1.5, 1.2.1, 1.2.2, 1.2.3, 1.2.4.2,
1.2.5, 1.2.6, 1.3.1, 1.3.2, 1.3.3, 1.3.4, 1.3.9,
1.5.1, 1.5.2, 1.5.4, 1.5.5, 1.5.6, 1.5.7, 1.5.8,
1.5.9, 1.5.10, 1.5.11, 1.5.13, 1.6.1, 1.6.2, 1.6.4,
1.7.1.1, 1.7.1.2, 1.7.2, 1.7.3, 1.7.4.3.

Standards applied:

EN 12453:2017+A1:2021

Industrial, commercial and garage doors and
gates - Safety in use of power operated doors -
Requirements

EN 12978:2003+A1:2009

Industrial, commercial and garage doors and
gates - Safety devices for power operated doors
and gates - Requirements and test methods

EN 60335-2-103:2015

Household and similar electrical appliances -
Safety - Part 2-103: Particular requirements for
drives for gates, doors and windows

EN 61000-6-2:2005

Electromagnetic compatibility (EMC) Part 6-2
Generic standards – Immunity standard for
industrial environments

EN 61000-6-3:2007

Electromagnetic compatibility (EMC) Part 6-3
Generic standards – Emission standard for
residential, commercial and light-industrial
environments

Declaration of incorporation

within the meaning of Supply of Machinery (Safety) Regulations 2008
for partly completed machinery, Appendix II Part B



Declaration of conformity

within the meaning of Electromagnetic Compatibility Regulations 2016
within the meaning of Restriction of the Use of Certain Hazardous Substances in Electrical
and Electronic Equipment Regulations 2021

We,
GfA ELEKTROMATEN GmbH & Co. KG
declare under our sole responsibility that the
following product complies with the above directives
and is only intended for installation in a door system.

Door control
TS970

We undertake to transmit in response to a reasoned
request by the appropriate regulatory authorities the
special documents on the partly completed
machinery.

This product must only be put into operation when it
has been determined that the complete
machine/system in which it has been installed
complies with the provisions of the above-mentioned
directives.

Authorised representative:
Andrew Collett
GfA ELEKTROMATEN UK Ltd
Tournament Fields Business Park,
Agincourt Rd,
Warwick CV34 6XZ

Düsseldorf, 01.05.2023

Stephan Kleine
CEO

A handwritten signature in black ink, appearing to read 'S. Kleine', with a horizontal line extending to the right.

Signature

The following requirements from Appendix I of the
Supply Machinery (Safety) Regulations 2008 are
met:

1.1.2, 1.1.3, 1.1.5, 1.2.2, 1.2.3, 1.2.6, 1.3.2, 1.3.3,
1.3.9, 1.5.1, 1.5.2, 1.5.4, 1.5.6, 1.5.7, 1.5.8, 1.5.9,
1.5.10, 1.5.11, 1.5.13, 1.6.1, 1.6.2, 1.6.4, 1.7.2, 1.7.3,
1.7.4.3.

Applied Standards:

BS EN 12453:2022

Industrial, commercial and garage doors and gates -
Safety in use of power operated doors -
Requirements

BS EN 12978:2003+A1:2009

Industrial, commercial and garage doors and
gates - Safety devices for power operated doors
and gates - Requirements and test methods

BS EN 60335-2-103:2015

Household and similar electrical appliances -
Safety - Part 2-103: Particular requirements for
drives for gates, doors and windows

BS EN 61000-6-2:2005

Electromagnetic compatibility (EMC) Part 6-2
Generic standards – Immunity standard for
industrial environments

BS EN 61000-6-3:2007

Electromagnetic compatibility (EMC) Part 6-3
Generic standards – Emission standard for
residential, commercial and light-industrial
environments