



# Installation instructions

## Safety brake

FG 120-50 Ex

For use in potentially explosive atmospheres (Ex)

Type: 10002534 00001

-en-

Version: 08.04.2024



GfA ELEKTROMATEN GmbH & Co. KG  
Wiesenstraße 81 • 40549 Düsseldorf

🌐 [www.gfa-elektromaten.de](http://www.gfa-elektromaten.de)  
✉ [info@gfa-elektromaten.de](mailto:info@gfa-elektromaten.de)

## Table of contents

1	General safety information .....	4
2	Technical data .....	5
3	Technical data of limit switch / switch for manual operation.....	5
4	Function .....	6
5	Mechanical installation .....	7
6	Electrical installation .....	11
7	Safety brake activation.....	13
8	Repairs.....	14
9	Completion of initial operation / inspection.....	15
10	Declaration of conformity.....	16
11	Declaration of conformity.....	16
12	Konformitätserklärung Zubehör .....	18

### Symbols



**Warning** - Potential injury or danger to life!



**Warning** - Danger to life from electric current!



**Note** - Important information!



**Requirement** - Required action!

Schematic representations are based on product examples. Deviations from delivered products are possible.



## 1 General safety information

### Specified normal use

The safety brake is intended for loads which must be secured against falling down. The device can be used in potentially explosive atmospheres according to the ATEX directive 2014/34/EU. The safety brake is mounted directly onto the shaft. The safety brake is activated automatically in the case of trapping. The function depends on speed and rotary direction. The safe operation is only guaranteed with specified normal use. No liability for damage caused by other applications or non-observance of the information in the manual. Modifications are only permitted with the agreement of the manufacturer. Otherwise the Manufacturer's Declaration shall be rendered null and void.

### Safety information

Installation and commissioning are to be carried out by skilled personnel only.

Only trained electrical craftsmen are permitted to work on electrical equipment. They must assess the tasks assigned to them, recognise potential danger zones and be able to take appropriate safety measures.

Installation work is only to be carried out with the supply off.

Observe the applicable regulations and standards.

### Coverings and protective devices

Do not operate unless corresponding coverings and protective devices are installed.

Ensure that cable glands are correctly tightened.

### Spare parts

Only use original spare parts.

## 2 Technical data

Series	FG 120-50 Ex	
Explosion protection	II 2G Ex h IIC T3 Gb	
Max. torque	1200	Nm
Output / hollow shaft (Ø)	50	mm
Locking torque	3530	Nm
Safety brake (approval number)	TorFV 3/009	
Maximum operating speed OPEN / CLOSE	24 / 24	rpm
Admissible bearing load $F_{max}$	6000	N
Keyway width	14	mm
Keyway height	53.8	mm
Degree of protection	IP 65	
Admissible temperature range	-20 / +40	°C

## 3 Technical data of limit switch / switch for manual operation

Type	07-2581-116001	
Manufacturer	Bartec	
Explosion protection	II 2G Ex d IIC T6, T5 Gb II 2D Ex tb IIIC T80°C, T95°C DB	
Test certificate	EPS 14 ATEX 1 766 X	
Supply voltage	400	V
Temperature range	-20 / +40	°C
Degree of protection	IP 66	



### Attention – Damage to components!

- The maximum allowable current applied to the switch is 2A 400V for AC-15 and 0.15 250V for DC-13.

## 4 Function

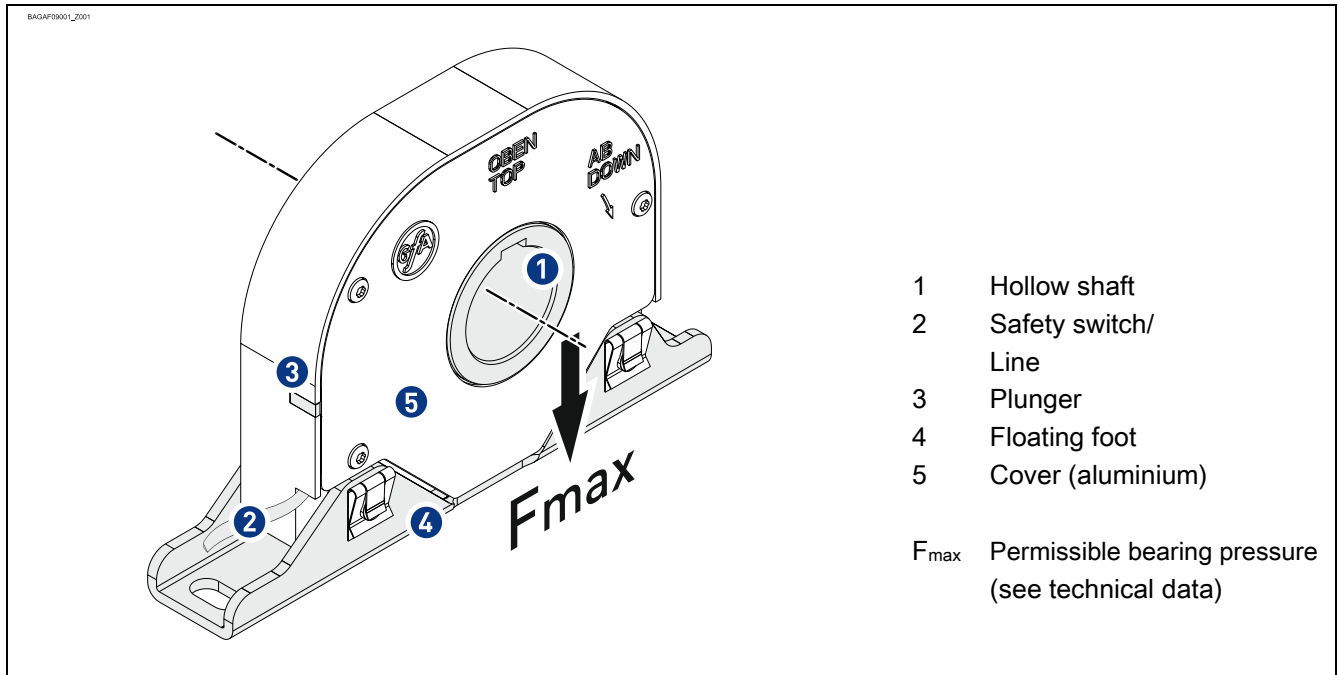

In normal operation, the safety brake functions similar to pedestal bearings. The safety brake is tripped as soon as the maximum operating speed in DOWN direction is exceeded. This results in the following reactions:

- The shaft is blocked in DOWN direction (1).
- The safety switch is actuated to interrupt the control current (2).
- Release is optically indicated by a red plunger (3).

Operating position:

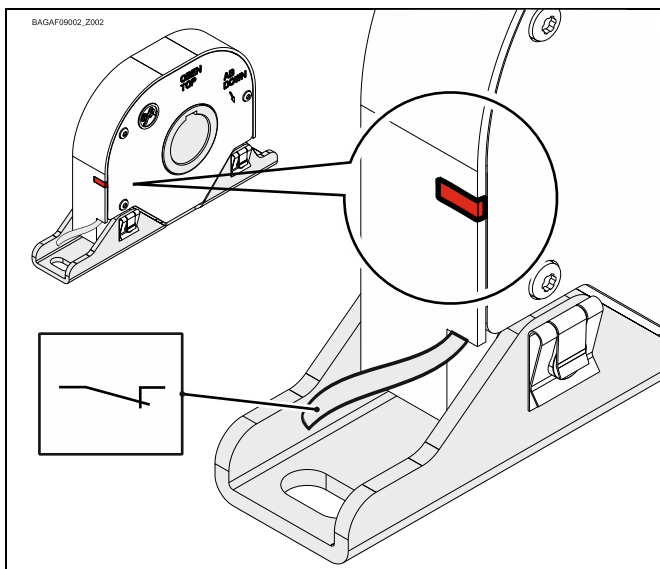

Braking position:

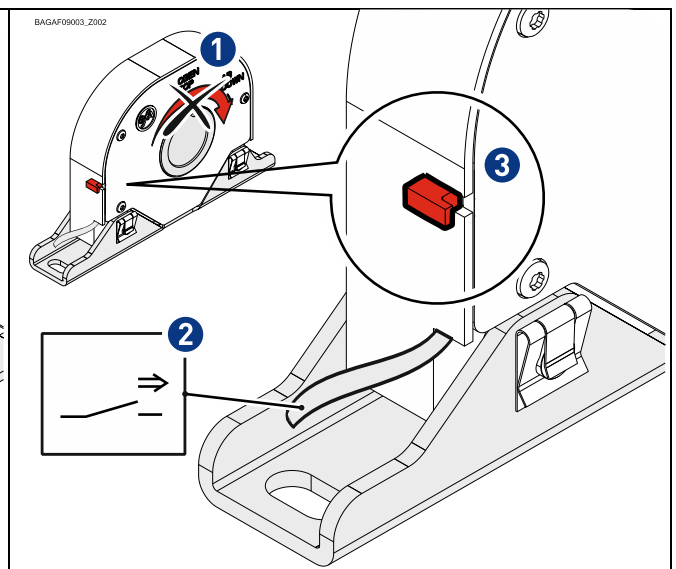

## 5 Mechanical installation

### Requirements

The permissible loads on walls, mountings, connection and transmission elements must not be exceeded even for maximum locking torque (► observe technical data).

### Connection elements:

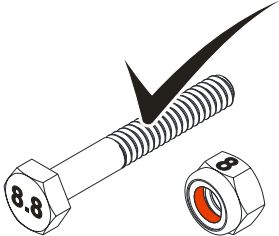
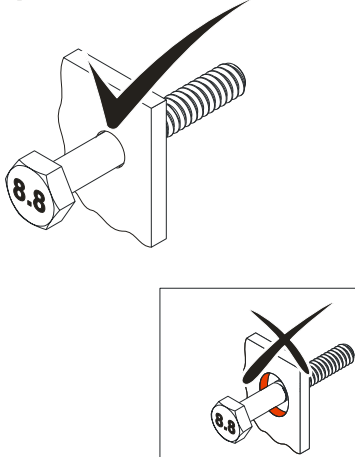
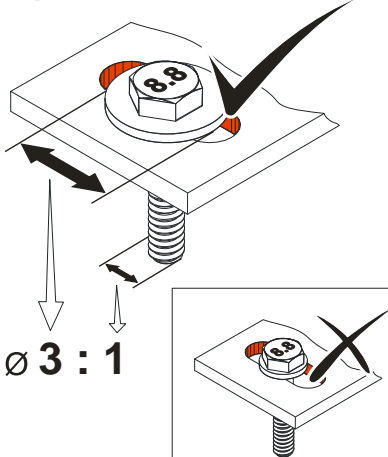
<p>Use self-locking connection elements with a minimum strength of 800 N/mm<sup>2</sup> (8.8).</p>	<p>Use a screw that precisely fits the hole.</p>	<p>Use adequately dimensioned washers for elongated holes.</p>
<p><small>BAGAB00001_Z002</small></p>  <p><b>≥ 800 N/mm<sup>2</sup></b></p>	<p><small>BAGAB00002_Z002</small></p> 	<p><small>BAGAB00003_Z002</small></p>  <p>Ø 3 : 1</p>

### Permissible mounting positions

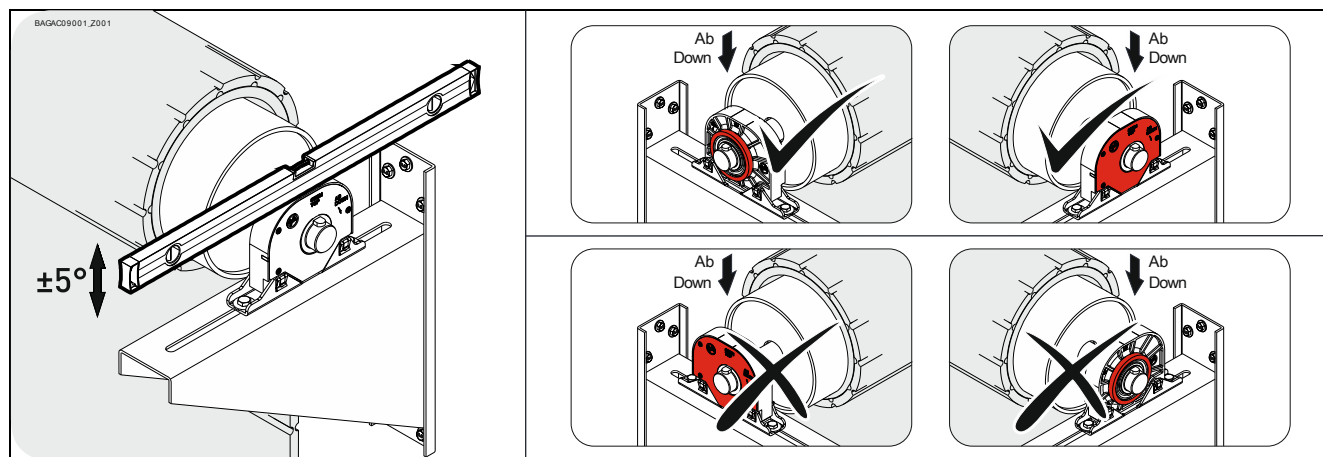

## Mounting

2 elongated holes are provided for mounting.

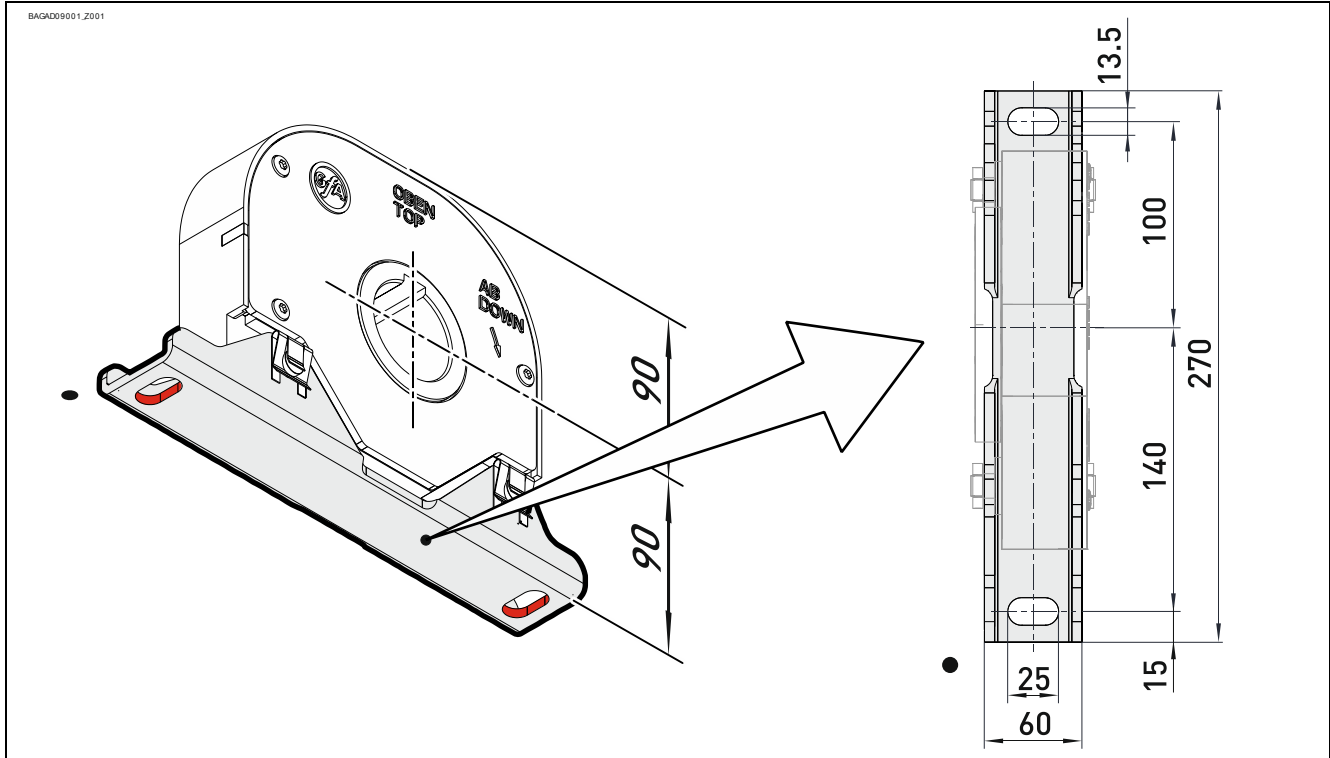



## Installation

The following descriptions refer to a facility or door which is not further defined. The facility or door manufacturer's specifications must also be observed.



**Warning – Injury or danger to life possible!**

- Use a lifting device with sufficient load-carrying capacity for installation tasks.

Completely grease the door shaft.

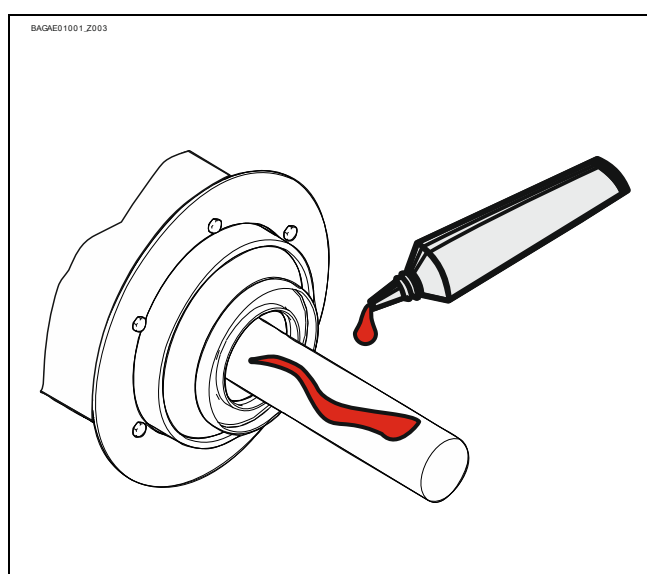

Mount the key.

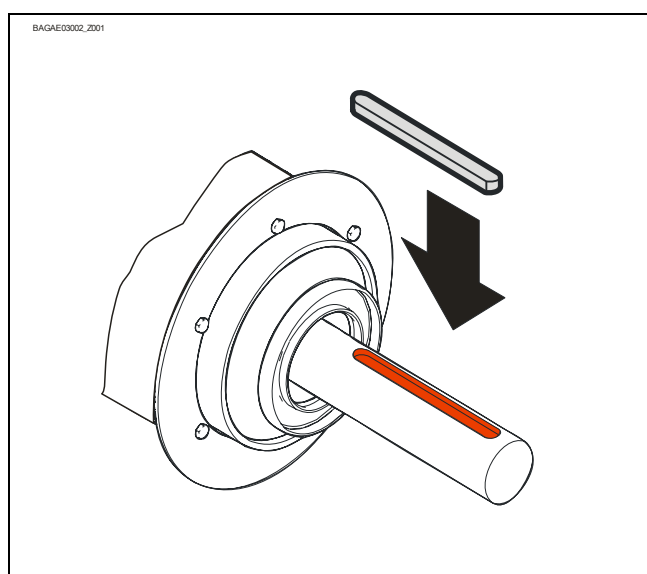

Attach safety brake. Observe rotating direction.

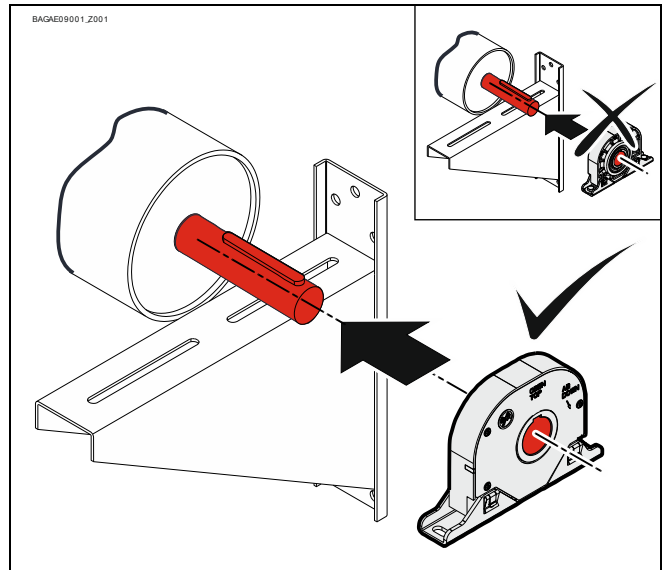

Tighten all connection elements (M12) with a torque of 75 Nm. Install all further connection elements according to the specifications of the door or facility manufacturer.

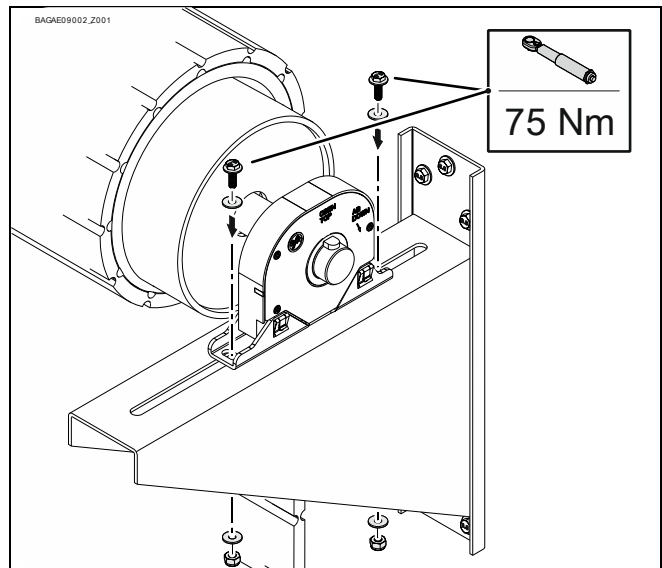

**Note**

If the safety brake has been tripped during installation, follow the procedure described under *Safety brake activation*.

## 6 Electrical installation



### Warning – Danger to life due to electrical current!

- Disconnect the cables (mains OFF) and check that the supply is off
- Observe applicable regulations and standards
- Ensure proper electrical connection
- Use suitable tools



### Warning - Danger due to uncontrolled movement!

The connection cable of the safety brake must be protected against cross-faults. If a cross-fault occurs, the safety switch does not interrupt the control current. A movement of the door due to a movement command cannot then be ruled out.

- Ensure that the installed connection cable is protected.

**Cross-fault:** A cross-fault is a short circuit between two wires inside a cable.

The integrated safety switch of the safety brake functions as an NC contact. Connect the cable of the safety switch to the EMERGENCY STOP input of the door control. When the safety brake is activated, the electrical circuit is interrupted and the electrical operation of the gate is no longer possible.

## Carrying out the electrical installation

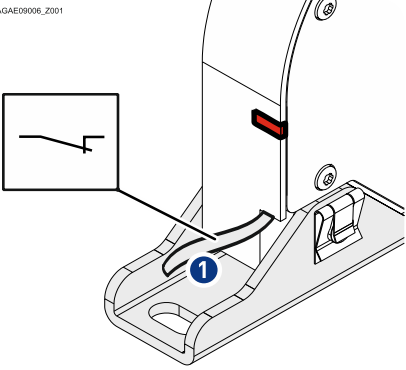
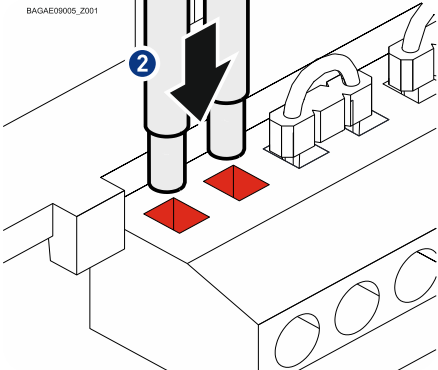
Cable of the safety brake's safety switch (1)	Connection of the cable to the EMERGENCY STOP input of the door control (2)
 <p>BAGAE09006_Z001</p>	 <p>BAGAE09005_Z001</p>



**Warning – Injury or danger to life possible!**

- The safety switch of the safety brake must not be connected to the drive unit.

## Completing the electrical installation

Install cable entries and/or cable glands.

## 7 Safety brake activation

The safety brake is tripped as soon as the maximum operating speed in DOWN direction is exceeded. This results in the following reactions:

- The shaft is blocked in DOWN direction (1).
- The safety switch is actuated to interrupt the control current (2).
- Release is optically indicated by a red

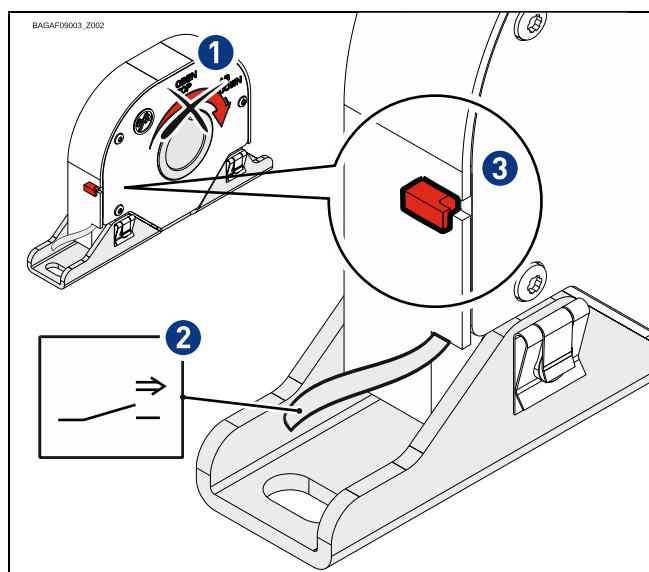

### Warning!

- De-energise the facility and secure against unintended switching-on.
- Secure door/load against falling.
- Rectify the cause of tripping (drive unit, chain, etc.).

Any time the safety brake has been tripped, it must be disassembled and checked. If the control pointer (1) is damaged, the safety brake must be replaced.

<p>Unscrew (3xT20) cover (aluminium) and assess control pointer (1).</p>	<p>Control pointer broken. ⇒ A Replace safety brake!</p>	<p>Control pointer damaged. ⇒ B Replace safety brake!</p>	<p>Control pointer not damaged. ⇒ C Repair safety brake.</p>

## 8 Repairs

If the control pointer is not damaged (see *Safety brake activation* – ©), the safety brake can be repaired.

Rotate hollow shaft in OPEN direction by approx. 90°.

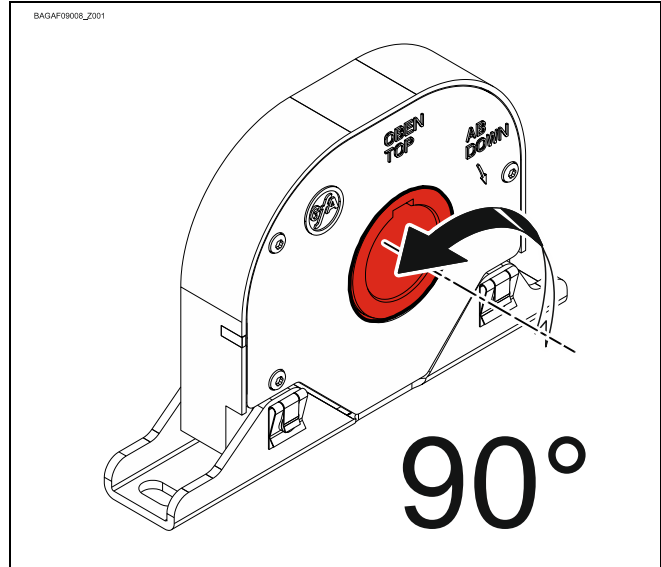

Press the red plunger back into the housing.  
The safety brake is ready for operation again.

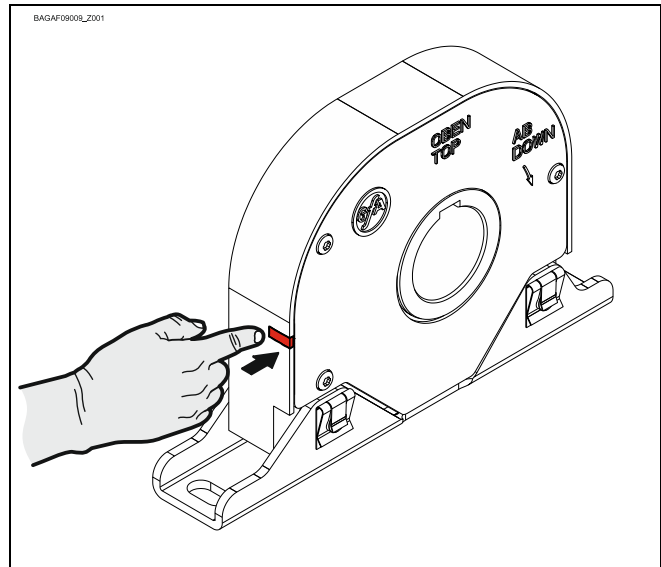

## 9 Completion of initial operation / inspection

Check the following components and after that, mount all covers.

### Mounting

Check all mounting elements (consoles, screws, retaining rings etc.) for tightness and impeccable condition.

### Electric wiring

Check connection cables and cables for damage or pinches.



Warning – Injury or danger to life possible!

- Do not activate the safety brake without having connected the safety switch!

Check screw and plug connections for correct seating and electrical contact.

### Mounting position

On the basis of the OBEN/TOP and AB/DOWN markings and by checking.

### Maintenance/inspection

The safety brake requires no maintenance.

The safety brake is type-approved. Checking for correct functioning is not required and inadmissible once the safety brake is installed.

### Entire safety brake



Note!

- Have a specialist check the safety brake once a year.
- Shorter inspection interval for frequently used equipment or doors.
- Observe the applicable regulations and standards

# Declaration of conformity

within the meaning of Machinery Directive 2006/42/EC

within the meaning of RoHS Directive 2011/65/EU



GfA ELEKTROMATEN GmbH & Co. KG  
Wiesenstraße 81 · 40549 Düsseldorf  
Germany

We,  
**GfA ELEKTROMATEN GmbH & Co. KG**  
declare under our sole responsibility that the  
following product complies with the above  
directives and is only intended for installation in a  
door system.

Safety brake

**FG 120-50 Ex**

Part no.: 10002534 00001

Authorised representative to compile the  
technical documents is the undersigned.

Düsseldorf, 10.08.2018

**Stephan Kleine**

CEO

Signature

Standards applied:

**EN 12604:2017**

Industrial, commercial and garage doors and  
gates - Mechanical aspects - Requirements

**EN 12605:2000**

Industrial, commercial and garage doors and  
gates - Mechanical aspects - Test methods

**EN 60204-1:2006**

Safety of machinery - Electrical equipment of  
machines - Part 1: General requirements



# Declaration of conformity

within the meaning of Explosion Protection Directive 2014/34/EU  
regarding the safe assembly of components



GfA ELEKTROMATEN GmbH & Co. KG  
Wiesenstraße 81 · 40549 Düsseldorf  
Germany

---

We,

**GfA ELEKTROMATEN GmbH & Co. KG**

declare under our sole responsibility that the  
following module complies with the above  
directive and that no new hazards arise from  
assembly. The assembled modul are only  
intended for installation in a door system.

Safety brake

**FG 120-50 Ex**

Part no.: 10002534 00001

Consisting of:

Safety brake FG 120-50 Ex

Safety switches: 07-2511

Higher-level product identification code

⊕ II 2G Ex db h IIC T3 Gb

Authorised representative to compile the  
technical documents is the undersigned.

Düsseldorf, 01.10.2019

**Stephan Kleine**

CEO

Signature

EU Konformitätserklärung  
 EU Declaration of Conformity  
 Déclaration UE de conformité

**BARTEC**

BARTEC GmbH  
 Max-Eyth-Straße 16  
 97980 Bad Mergentheim  
 Germany

N° 01-2511-7C0001\_A

Wir	We	Nous
<b>BARTEC GmbH,</b>		
erklären in alleiniger Verantwortung, dass das Produkt	declare under our sole responsibility that the product	attestons sous notre seule responsabilité que le produit
<b>Endschalter</b>	<b>Limit Switch</b>	<b>Fin de course</b>
<b>Typ 07-2511-...../.....; 07-2581-...../.....</b>		
auf das sich diese Erklärung bezieht den Anforderungen der folgenden <b>Richtlinien (RL)</b> entspricht	to which this declaration relates is in accordance with the provision of the following <b>directives (D)</b>	se référant à cette attestation correspond aux dispositions des <b>directives (D)</b> suivantes
<b>ATEX-Richtlinie 2014/34/EU</b>	<b>ATEX-Directive 2014/34/EU</b>	<b>ATEX-Directive 2014/34/UE</b>
<b>RoHS-Richtlinie 2011/65/EU</b>	<b>RoHS-Directive 2011/65/EU</b>	<b>RoHS-Directive 2011/65/UE</b>
und mit folgenden Normen oder normativen Dokumenten übereinstimmt	and is in conformity with the following standards or other normative documents	et est conforme aux normes ou documents normatifs ci-dessous
<b>EN 60079-0:2012 EN 60079-1:2014</b>		<b>EN 60079-31:2014</b>
<b>Kennzeichnung</b>	<b>Marking</b>	<b>Marquage</b>
	II 2G Ex d IIC T6,T5 Gb II 2D Ex tb III C T80°C, T95°C Db	
<b>Verfahren der EU-Baumusterprüfung / Benannte Stelle</b>	<b>Procedure of EU-Type Examination / Notified Body</b>	<b>Procédure d'examen UE de type / Organisme Notifié</b>
<b>EPS 14 ATEX 1766 X</b>		
2004, Bureau Veritas Germany GmbH, 86842 Türkheim		
<b>CE 0044</b>		
Bad Mergentheim, den 22.04.2016		
 i.V. Ernst Gruber Head of ExCo/MeCo		 i.V. Michael Schulte Leiter GW PZ

# Declaration of conformity

within the meaning of Explosion Protection Directive 2014/34/EU



GfA ELEKTROMATEN GmbH & Co. KG  
Wiesenstraße 81 · 40549 Düsseldorf  
Germany

We,  
GfA ELEKTROMATEN GmbH & Co. KG  
declare under our sole responsibility that the  
following module complies with the above  
directive and that no new hazards arise from  
assembly. The assembled modul are only  
intended for installation in a door system.

Safety brake

**FG 120-50 Ex**

Part no.: 10002534 00001

Authorised representative to compile the  
technical documents is the undersigned.

Düsseldorf, 01.10.2019

**Stephan Kleine**  
CEO

Signature

Identification of the product according to  
Directive:  II 2G Ex h IIC T3 Gb

Notified body pursuant to Directive:  
TÜV Nord Anlagetechnik GmbH  
Am TÜV 1  
30519 Hannover, Deutschland

Registration number: 8000313442

Standards applied:

**EN ISO 80079-36:2016**

Explosive atmospheres -

Part 36: Non-electrical equipment for explosive  
atmospheres - Basic method and requirements.

**EN ISO 80079-37:2016**

Explosive atmospheres -

Part 37: Non-electrical equipment for explosive  
atmospheres - Non-electrical type of protection  
constructional safety "c", control of ignition  
sources "b", liquid immersion "k".

