



# Installation Instructions

**ELEKTROMAT  
FT 60.4-45,00**

Model: 10003292 00011

**-en-**

Status: 01.03.2026







GfA ELEKTROMATEN GmbH & Co. KG  
Wiesenstraße 81  
D-40549 Düsseldorf  
🌐 [www.gfa-elektromaten.de](http://www.gfa-elektromaten.de)  
✉ [info@gfa-elektromaten.de](mailto:info@gfa-elektromaten.de)

## Table of contents

1	General safety information .....	4
2	Technical data .....	6
3	Mechanical installation .....	7
4	Electrical installation .....	10
5	Limit switch adjustment .....	12
6	Motor connection .....	14
7	Alternative motor connection .....	14
8	Limit switch connection .....	15
9	Emergency manual operation lever .....	16
10	Completing commissioning / inspection .....	17
11	Disposal .....	18
12	Declaration of incorporation / Declaration of conformity .....	19
13	UKCA: Declaration of incorporation / Declaration of conformity .....	20

-

<b>Symbols</b>	
	<b>Warning</b> - Potential injury or danger to life!
	<b>Warning</b> - Danger to life from electric current!
	<b>Note</b> - Important information!
	<b>Requirement</b> - Required action!

Schematic representations are based on product examples. Deviations from delivered products are possible.



---

## 1 General safety information

### **Specified normal use**

The drive unit is intended for horizontally-driven folding doors.

The drive unit must be protected against moisture and aggressive environmental conditions (such as corrosive substances). The drive units are only suitable for indoor use. Appropriate protective measures must be taken for outdoor installation. The drive unit is not intended for hazardous areas. The values specified in the technical data of the drive unit must not be exceeded. The safe operation can only be ensured if used as specified.

### **Target audience of these installation instructions**

These installation instructions are geared towards qualified persons trained in the handling of door systems. Expert knowledge, relevant skills and practical experience are what set apart qualified persons. They are capable of safely carrying out the tasks involving installation, maintenance and modernisation according to the instructions.

### **Safe operation**

The safe operation of the product can only be ensured if it is used as specified. Follow the installation instructions. Observe all specifications, especially warnings, when installing the product in the overall system. GfA is not liable for damage resulting from non-observance of the installation instructions. The resulting overall system must be reassessed for its safety in accordance with applicable standards and directives (e.g. CE marking). These installation instructions refer only to a part of the overall system and are not sufficient as the sole instructions for the overall system. The installer of the system must prepare the instructions for the overall system. We recommend entering the danger area of the system only when the drive unit is at a standstill.



**Warning - Failure to follow these installation instructions may result in severe injury or death.**

- Please read these instructions before using the product.
- Keep these instructions handy.
- Include these instructions when passing on the product to third parties.



**Warning - Danger from improper use of the product!**

- Do not let children operate the product unsupervised or use as a toy.



**Warning - Danger to life from incorrect installation!**

Work carried out improperly may result in death or severe injury from electrical current or falling parts.

- Allow only competent people to carry out the work.
- Disconnect all cables from the power supply.
- Observe valid regulations and standards.
- Use suitable tools.



**Warning! Danger to life from falling objects if the drive unit is subjected to impermissible forces.**

Inadmissible forces (examples: collision with a forklift, dropping the drive unit, tearing or pulling on the motor) lead to damage to the drive unit. There is a risk of severe injury or death from falling objects.

- Prevent impermissible forces from acting on the drive unit,
- Check the drive unit for damage if impermissible forces have acted on it. Look even for minor damage. Lock the door during the inspection.
- Contact the service department if you have difficulty assessing the damage.

## 2 Technical data

Designation		Unit
Output speed	4	rpm
Output torque	600 (470) <sup>1)</sup>	Nm
Output / hollow shaft	45,00	mm
Series	FT SG50/SG85	-
Limit switch range (maximum revolutions of the output / hollow shaft)	1	-
Supply voltage	3N~ 400	V
Operating current	1,10	A
Operating frequency	50	Hz
Power factor cos φ	0,87	-
Safety circuit	24	V
Degree of protection	IP 65	-
Temperature range	-10 / +40 [+60] <sup>2)</sup>	°C
Operating sound pressure level	< 70	dB(A)
Maximum output speed OPEN / CLOSE for frequency inverter operation	7 / 7	min <sup>-1</sup>
Cycles per hour	18 (17,0) <sup>1)</sup>	h <sup>-1</sup>
Max. holding torque	2900	Nm

1) Specification in ( ) according to EN 60335-2-103. One cycle consists of a complete opening and closing movement of the door. If the limit switch range is not fully used, the number of possible cycles can be increased relative to the reduced number of revolutions of the output shaft. Calculation of the break time according to IEC EN 60335-2-103:

$$\text{Break time [min]} = \frac{60[\text{s}]}{\text{Number of cycles [h}^{-1}\text{]}} - \frac{\text{Limit switch revolutions} + 2}{\text{output speed [min}^{-1}\text{]}}$$

2) When using a temperature range of +40° ...+60° C use half of maximum cycles per hour.



### Caution - Component damage can result!

- The maximum current that can be switched over the limit switch is 1A for 230 V AC and 0.4 A for 24V DC

### 3 Mechanical installation

#### Prerequisites

The permissible loads on walls, fastenings, mountings and transmission elements must not be exceeded, even for maximum holding torques or locking torques (▶ refer to technical data).

#### Connection elements

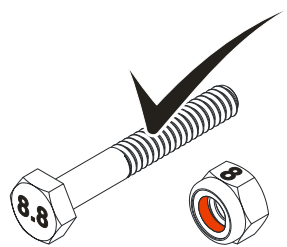
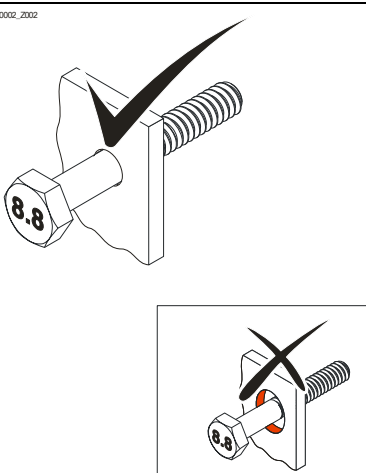
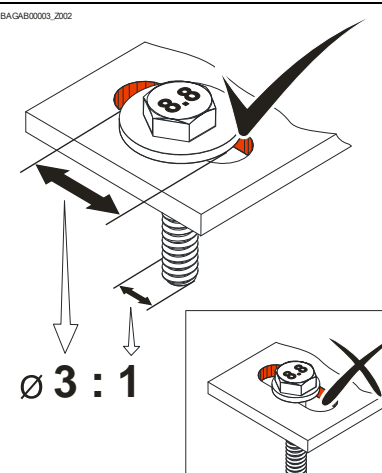
<ul style="list-style-type: none"> <li>Self-locking connection elements with a minimum strength of 800 N/mm<sup>2</sup> (8.8) must be used.</li> </ul>	<ul style="list-style-type: none"> <li>Utilize the hole diameter to the full.</li> </ul>	<ul style="list-style-type: none"> <li>Use adequately dimensioned washers for elongated holes.</li> </ul>
<p>BAGAB00001_Z002</p>  <p>≥ 800 N/mm<sup>2</sup></p>	<p>BAGAB00002_Z002</p> 	<p>BAGAB00003_Z002</p>  <p>∅ 3 : 1</p>

#### Permissible mounting positions

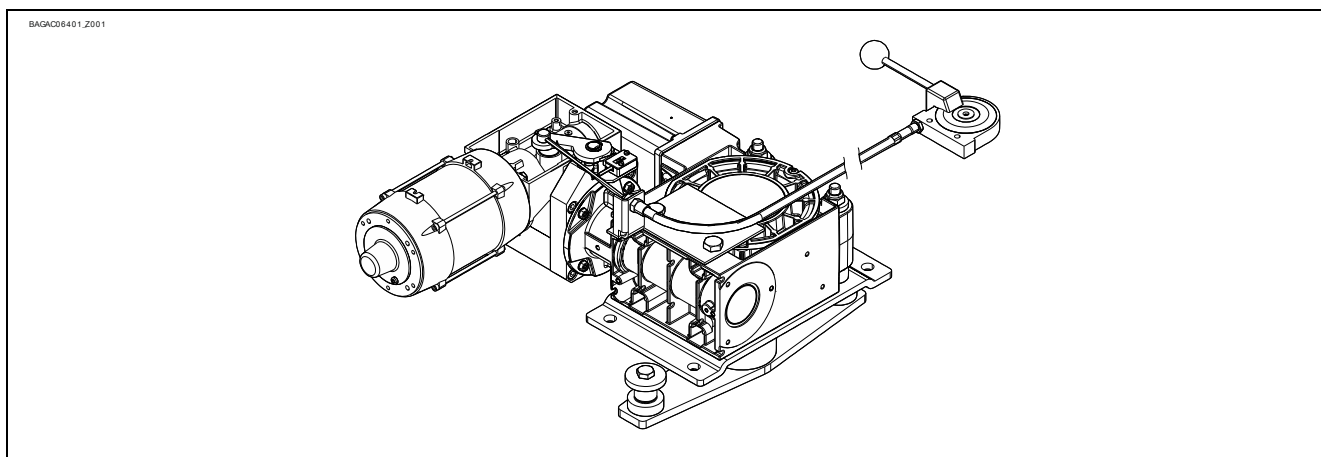

## Mounting

Four holes are provided for mounting.

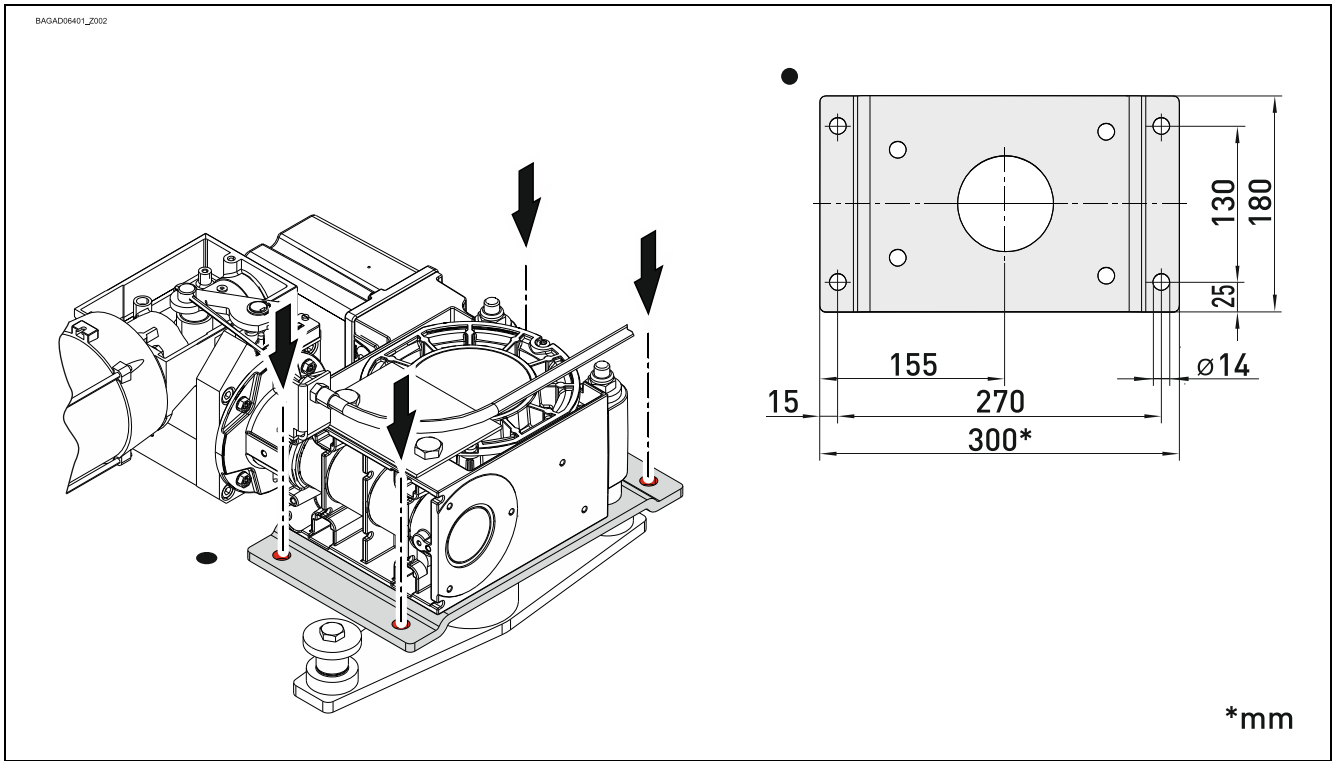

## Installation

The descriptions below apply to general door specifications. The specifications of the door manufacturer must also be observed during installation.



Warning - Potential injury or danger to life!

- During installation, be sure to use a lifting device that has a sufficient load-carrying capacity.

- Tighten all connection elements (M12) to 75 Nm. Install all other connection elements according to the specifications of the door manufacturer.

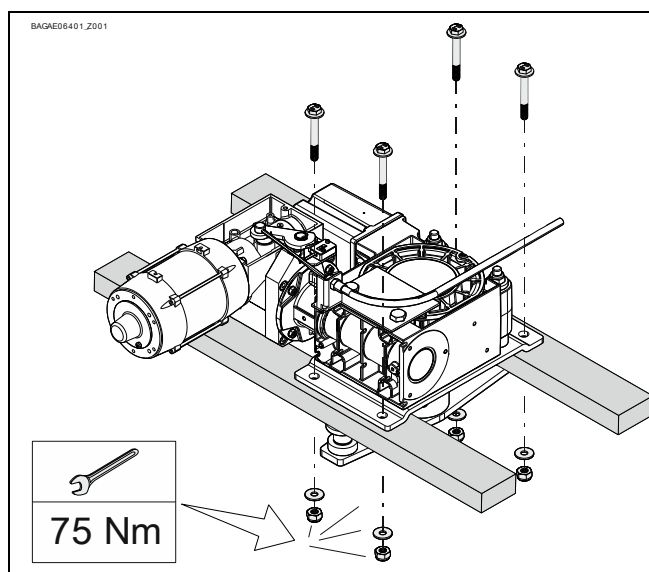

- The drive unit has a friction clutch as protection against overload. The friction clutch is set to the output torque. Turning to the left reduces the output torque.

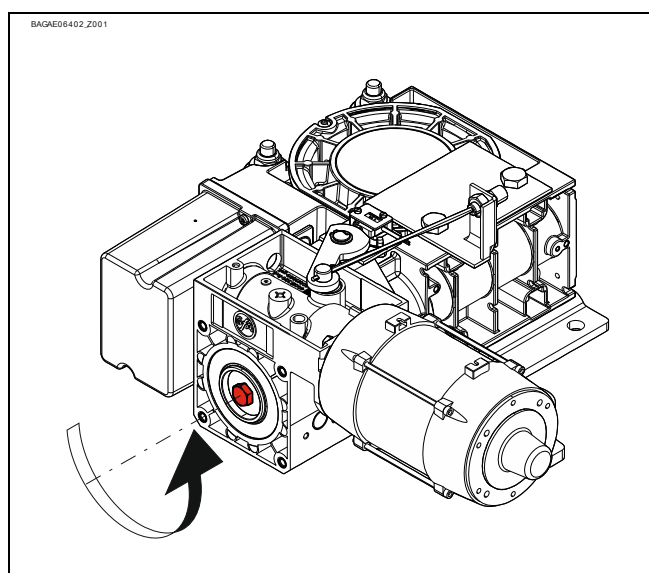

## 4 Electrical installation



**Warning - Danger to life from electric current!**

- Switch the mains OFF and check that the cables are de-energised
- Observe the applicable regulations and standards
- Make the electrical connection according to standard
- Use suitable tools

- Remove the cover.

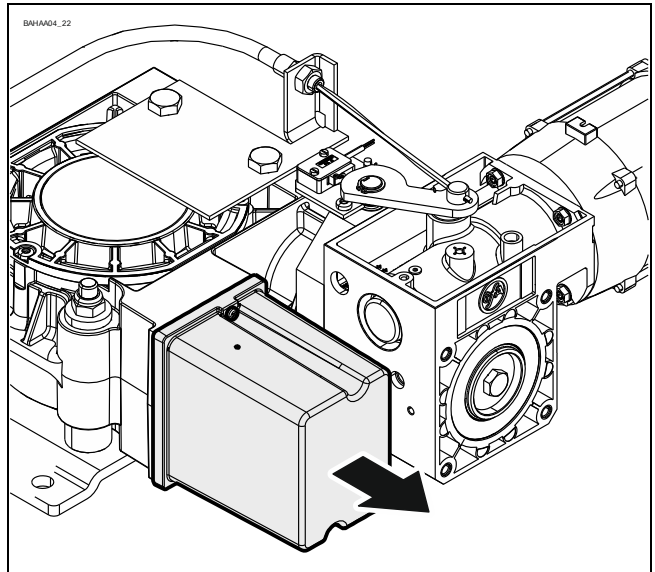

- Insert the motor plug.

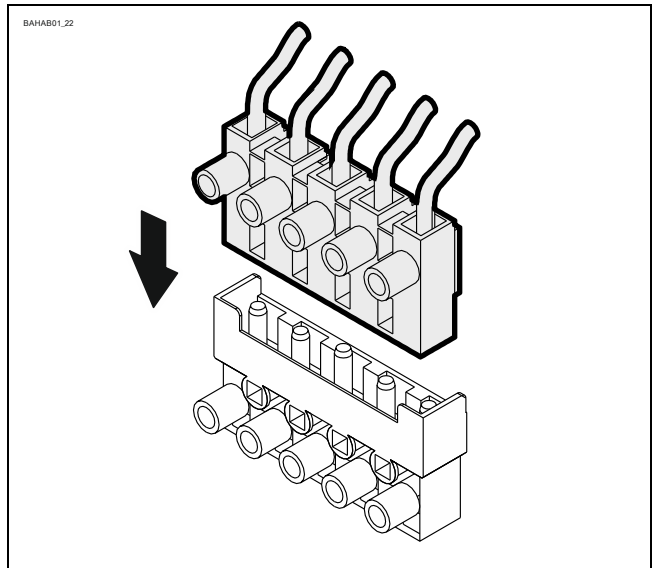

- Insert the limit switch plug.

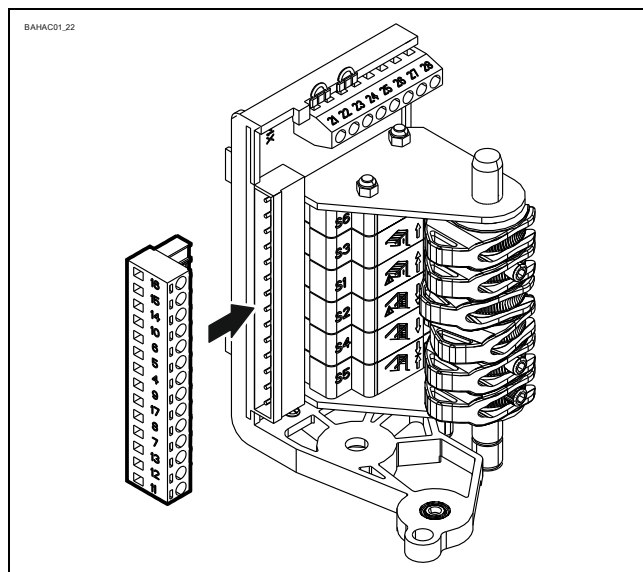

### Completing the electrical installation

Mount the cable entries and/or cable glands.

## 5 Limit switch adjustment

Adjust the limit switches to define the final limits positions for OPEN and CLOSE.

### Prerequisite

The door must open when the OPEN pushbutton is operated. If the door closes, L1 and L2 must be exchanged with the current switched off.

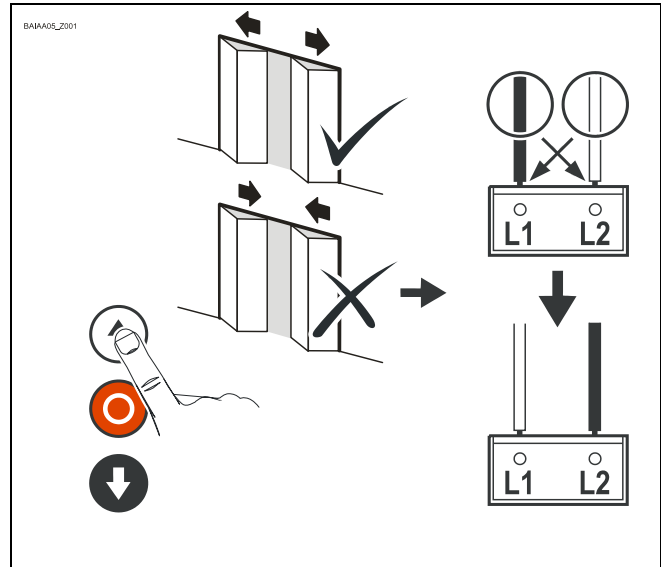

### Adjusting the OPEN limit position

Use the OPEN pushbutton to open the door to the desired OPEN final limit position.

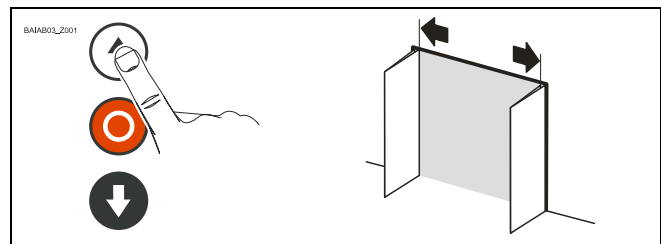

Rotate the cam of the OPEN limit switch S3 to the middle of tappet ①.  
Tighten the screw of the cam ②.

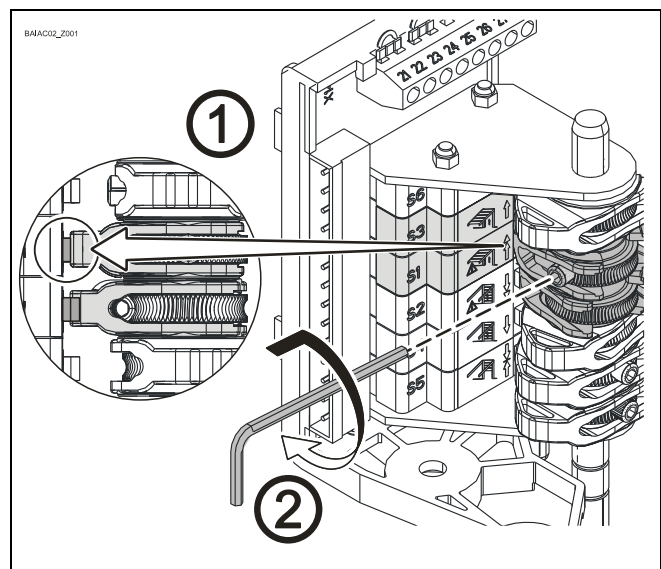

Check the position of the door:  
 Close the door ① until the cam is free and open the door again ② at OPEN final limit position.

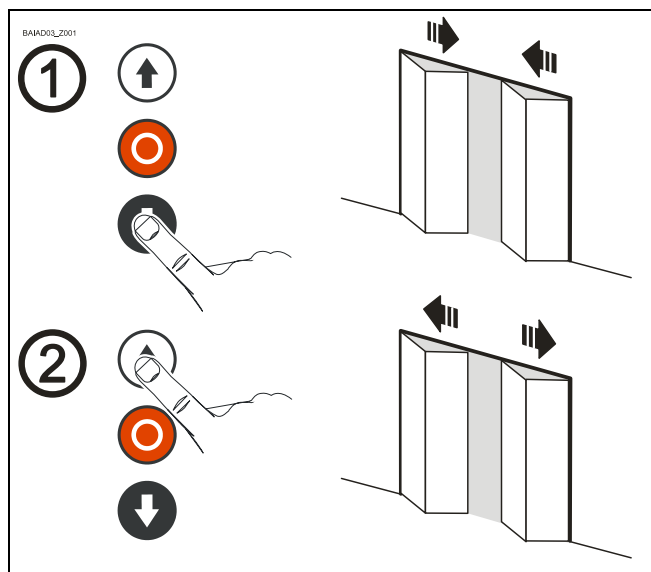

Carry out fine adjustment to correct the OPEN final limit position. Check the door position after correction.

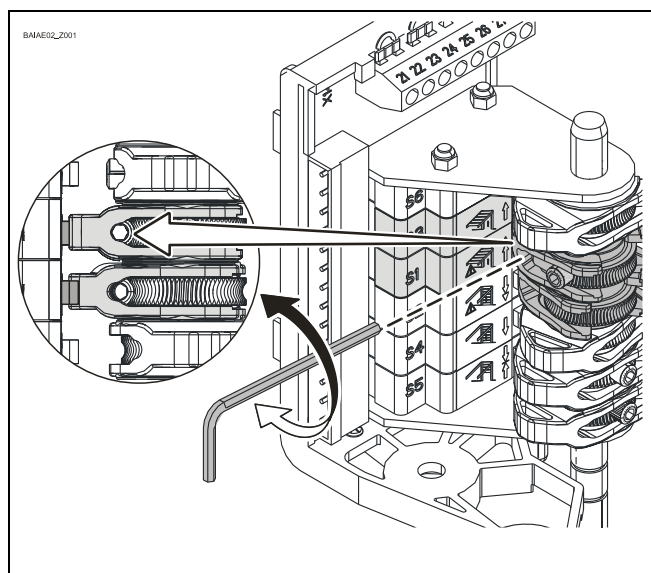

Adjusting the OPEN final limit position presets the OPEN SAFETY limit switch. The door must stop safely if the direction of rotation is wrong or the OPEN limit switch S3 fails. If necessary, carry out fine adjustment to correct the switching point of the limit switch.

### Adjusting the CLOSE final limit position and auxiliary limit switch

Carry out adjustment as for OPEN final limit position.

## 6 Motor connection

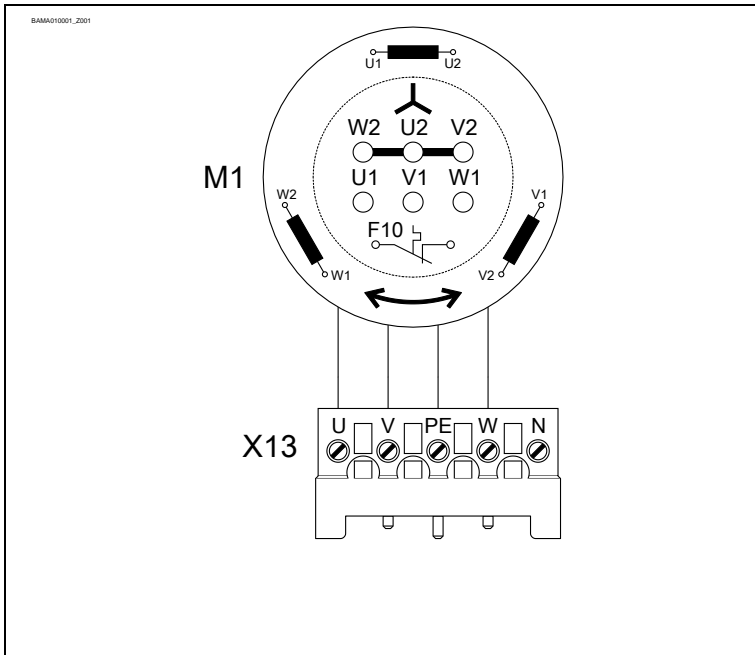

<b>M1</b>	Motor
<b>X13</b>	Motor plug

## 7 Alternative motor connection

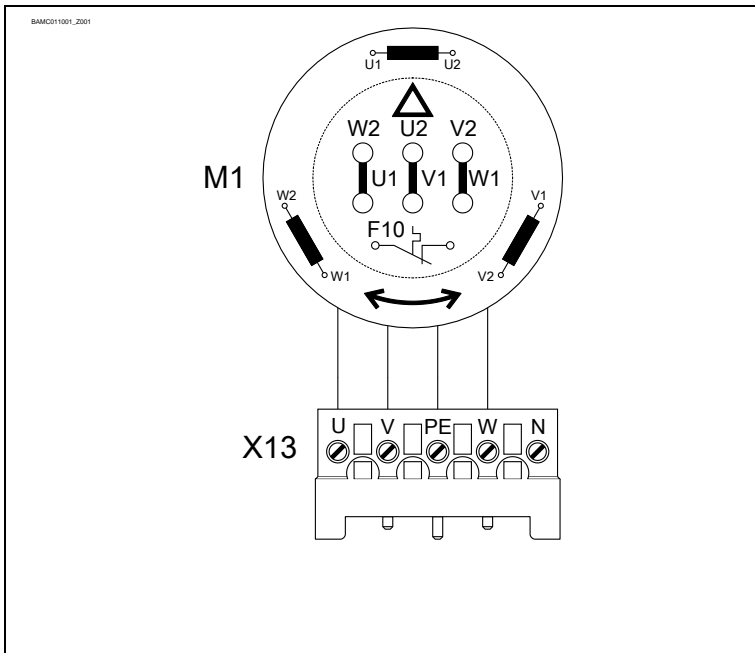

<b>M1</b>	Motor
<b>X13</b>	Motor plug

## 8 Limit switch connection

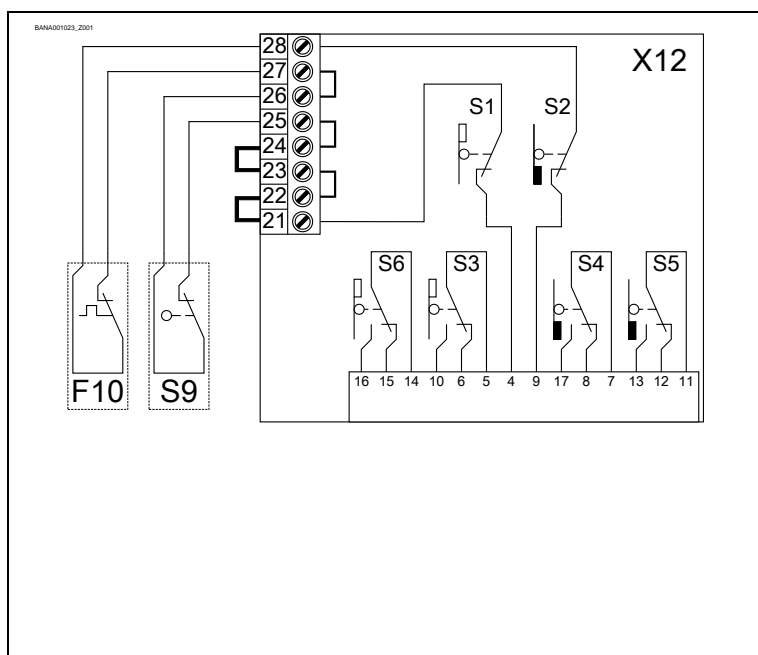

<b>F10</b>	Thermal contact
<b>S9</b>	Release switch
<b>X12</b>	Limit switch board
<b>S1</b>	Emergency OPEN limit switch
<b>S2</b>	Emergency CLOSE limit switch
<b>S3</b>	OPEN limit switch
<b>S4</b>	CLOSE limit switch
<b>S5</b>	Additional limit switch
<b>S6</b>	Additional limit switch

## 9 Emergency manual operation lever

The emergency manual operation is provided as a means of opening or closing doors that do not have electric power supply. Operation interrupts the control voltage. Electrical operation is no longer possible.



**Warning - Injury through improper operation!**

- Disconnect the voltage
- Door movement is possible after release

Turn the lever 180° to activate.

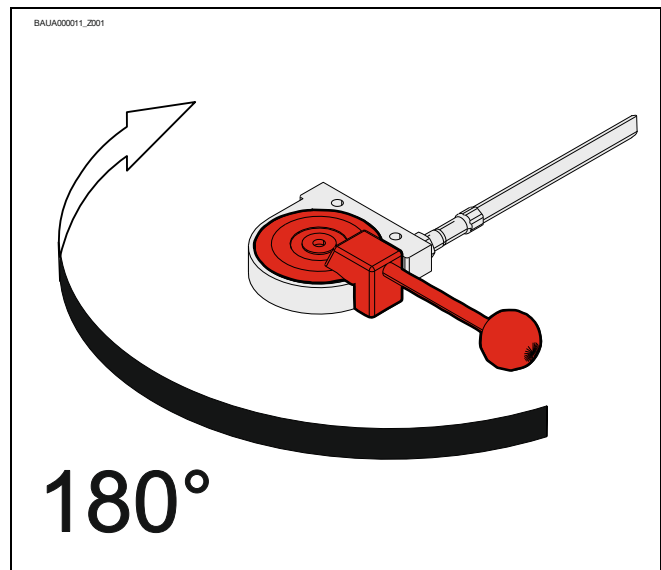

## 10 Completing commissioning / inspection

Check the following components and then install all covers.

### **Gearbox**

Check the drive unit for loss of oil (a few drops can be neglected). Protect the output-shaft permanently against corrosion.

### **Mounting**

Check that all connection elements (consoles, torque mounts, screws, locking rings, etc.) are secure and in proper condition.

### **Electrical wiring**

Check the connection cables and cabling for damage or crushing. Check that the screw connections and plug connections are fitted properly with a good electric contact.

### **Limit switch**

Check the final limit positions by opening and closing fully. The safety area must not be approached.

### **Drive unit**



#### **Note!**

- Engage a qualified engineer to check the drive unit annually
- Apply shorter inspection intervals for doors that are operated frequently
- Observe the applicable regulations and standards

## 11 Disposal

### Dispose of packaging

Dispose of the packaging material properly according to the local legal regulations or recycle it.

### Dispose of old devices

Dispose of old devices properly according to local legal regulations. Return old devices to the return and collection systems available. You can also return GfA products free of charge. Please apply enough postage to the package and mark it as "old devices".



#### **Notice- Environmental damage!**

The gearbox contains oil.

- Ensure proper disposal according to local legal regulations.

## Declaration of incorporation

within the meaning of Machinery Directive 2006/42/EC  
for partly completed machinery, Appendix II Part B



## Declaration of conformity

within the meaning of EMC Directive 2014/30/EU  
within the meaning of RoHS Directive 2011/65/EU

GfA ELEKTROMATEN GmbH & Co. KG  
Wiesenstraße 81 · 40549 Düsseldorf  
Germany

We,  
**GfA ELEKTROMATEN GmbH & Co. KG**  
declare under our sole responsibility that the  
following product complies with the above directives  
and is only intended for installation in a door system.

Drive unit

**FT 60.4-45,00**

Part no.: 10003292 00011

We undertake to transmit in response to a reasoned  
request by the appropriate regulatory authorities the  
special documents on the partly completed  
machinery.

This product must only be put into operation when it  
has been determined that the complete  
machine/system in which it has been installed  
complies with the provisions of the above-mentioned  
directives.

Authorised representative to compile the technical  
documents is the undersigned.

Düsseldorf, 10.08.2018

**Stephan Kleine**  
CEO



Signature

The following requirements from Appendix I of the  
Machinery Directive 2006/42/EC are met:

1.1.2, 1.1.3, 1.1.5, 1.2.2, 1.2.3, 1.2.6, 1.3.2, 1.3.3,  
1.3.9, 1.5.1, 1.5.2, 1.5.4, 1.5.6, 1.5.7, 1.5.8, 1.5.9,  
1.5.10, 1.5.11, 1.5.13, 1.6.1, 1.6.2, 1.6.4, 1.7.2, 1.7.3,  
1.7.4.3.

Standards applied:

**EN 12453:2017+A1:2021**

Industrial, commercial and garage doors and gates -  
Safety in use of power operated doors -  
Requirements

**EN 12604:2017**

Industrial, commercial and garage doors and gates -  
Mechanical aspects - Requirements

**EN 60335-1:2012**

Household and similar electrical appliances - Safety -  
Part 1: General requirements

**EN 61000-6-2:2005**

Electromagnetic compatibility (EMC) Part 6-2 Generic  
standards – Immunity standard for industrial  
environments

**EN 61000-6-3:2007**

Electromagnetic compatibility (EMC) Part 6-3 Generic  
standards – Emission standard for residential,  
commercial and light-industrial environments

## Declaration of incorporation

within the meaning of Supply of Machinery (Safety) Regulations 2008  
for partly completed machinery, Appendix II Part B

## Declaration of conformity

within the meaning of Electromagnetic Compatibility Regulations 2016  
within the meaning of Restriction of the Use of Certain Hazardous Substances in Electrical  
and Electronic Equipment Regulations 2012



We,  
**GfA ELEKTROMATEN GmbH & Co. KG**  
declare under our sole responsibility that the  
following product complies with the above directives  
and is only intended for installation in a door system.

Drive unit  
**FT 60.4-45,00**  
Part no.: 10003292 00011

We undertake to transmit in response to a reasoned  
request by the appropriate regulatory authorities the  
special documents on the partly completed  
machinery.

This product must only be put into operation when it  
has been determined that the complete  
machine/system in which it has been installed  
complies with the provisions of the above-mentioned  
directives.

Authorised representative:  
Andrew Collett  
GfA ELEKTROMATEN UK Ltd  
Tournament Fields Business Park,  
Agincourt Rd,  
Warwick CV34 6XZ

Düsseldorf, 01.11.2022

**Stephan Kleine**  
CEO

  
Signature

The following requirements from Appendix I of the  
Supply Machinery (Safety) Regulations 2008 are  
met:

1.1.2, 1.1.3, 1.1.5, 1.2.2, 1.2.3, 1.2.6, 1.3.2, 1.3.3,  
1.3.9, 1.5.1, 1.5.2, 1.5.4, 1.5.6, 1.5.7, 1.5.8, 1.5.9,  
1.5.10, 1.5.11, 1.5.13, 1.6.1, 1.6.2, 1.6.4, 1.7.2, 1.7.3,  
1.7.4.3.

Applied Standards:  
**BS EN 12453:2017+A1:2021**  
Industrial, commercial and garage doors and gates -  
Safety in use of power operated doors -  
Requirements

**BS EN 60335-2-103:2015**  
Household and similar electrical appliances -  
Safety - Part 2-103: Particular requirements for  
drives for gates, doors and windows

**BS EN 61000-6-2:2005**  
Electromagnetic compatibility (EMC) Part 6-2  
Generic standards – Immunity standard for  
industrial environments

**BS EN 61000-6-3:2007**  
Electromagnetic compatibility (EMC) Part 6-3  
Generic standards – Emission standard for  
residential, commercial and light-industrial  
environments