



Installation Instructions

ELEKTROMAT

KE 80.12-55,00 Ex

Model: 10005490 00001

-en-

Status: 08.04.2024



GfA ELEKTROMATEN GmbH & Co. KG
Wiesenstraße 81
D-40549 Düsseldorf
🌐 www.gfa-elektromaten.de
✉ info@gfa-elektromaten.de

Table of contents

1	General safety information	4
2	Technical data	6
3	Technical data gearbox.....	7
4	Technische Daten Motor	8
5	Technical data terminal box.....	9
6	Technical data limit switch / switch emergency manual operation.....	9
7	Mechanical installation	10
8	Electrical installation	15
9	Limit switch setting.....	18
10	Motor connection	20
11	Limit switch connection	20
12	Emergency manual operation (emergency hand crank)	21
13	Completion of initial operation / inspection / operation.....	23
14	Disposal	26
15	Konformitätserklärung Zubehör	30
16	Declaration of incorporation / Declaration of conformity	32
17	UKCA: Declaration of incorporation / Declaration of conformity.....	33

Symbols



Warning - Potential injury or danger to life!



Warning - Danger to life from electric current!



Note - Important information!



Requirement - Required action!

Schematic representations are based on product examples. Deviations from delivered products are possible.



1 General safety information

Specified use

The drive unit is intended for vertically moving doors. The force is transmitted using a chain. Doors that must be secured against dropping require a separate safety brake. The drive unit can be used in hazardous areas thanks to its explosion protection according to ATEX 2014/34/EU.

The drive unit must be protected against moisture and aggressive environmental conditions (such as corrosive substances). The drive units are only suitable for indoor use. Appropriate protective measures must be taken for outdoor installation. The values specified in the technical data of the drive unit must not be exceeded. The safe operation can only be ensured if used as specified.

Target audience of these installation instructions

These installation instructions are geared towards qualified persons trained in the handling of door systems. Expert knowledge, relevant skills and practical experience are what set apart qualified persons. They are capable of safely carrying out the tasks involving installation, maintenance and modernisation according to the instructions.

Safe operation

The safe operation of the product can only be ensured if it is used as specified. Follow the installation instructions. Observe all specifications, especially warnings, when installing the product in the overall system. GfA is not liable for damage resulting from non-observance of the installation instructions. The resulting overall system must be reassessed for its safety in accordance with applicable standards and directives (e.g. CE marking). These installation instructions refer only to a part of the overall system and are not sufficient as the sole instructions for the overall system. The installer of the system must prepare the instructions for the overall system. We recommend entering the danger area of the system only when the drive unit is at a standstill.



Warning - Failure to follow these installation instructions may result in severe injury or death.

- Please read these instructions before using the product.
- Keep these instructions handy.
- Include these instructions when passing on the product to third parties.



Warning - Danger from improper use of the product!

- Do not let children operate the product unsupervised or use as a toy.



Warning - Danger to life from incorrect installation!

Work carried out improperly may result in death or severe injury from electrical current or falling parts.

- Allow only competent people to carry out the work.
- Disconnect all cables from the power supply.
- Observe valid regulations and standards.
- Use suitable tools.



Warning! Danger to life from falling objects if the drive unit is subjected to impermissible forces.

Inadmissible forces (examples: collision with a forklift, dropping the drive unit, tearing or pulling on the motor) lead to damage to the drive unit. There is a risk of severe injury or death from falling objects.

- Prevent impermissible forces from acting on the drive unit,
- Check the drive unit for damage if impermissible forces have acted on it. Look even for minor damage. Lock the door during the inspection.
- Contact the service department if you have difficulty assessing the damage.

2 Technical data

Designation		Unit
Output speed	12	rpm
Output torque	800 (610) ¹⁾	Nm
Output / hollow shaft	55,00	mm
Series	SG 115	-
Limit switch range (maximum revolutions of the output / hollow shaft)	20	-
Supply voltage	3~ 400	V
Operating current	2,70	A
Operating frequency	50	Hz
Power factor cos ϕ	0,65	-
Safety circuit	24	V
Degree of protection	IP 65	-
Temperature range	-20 / +40	°C
Operating sound pressure level	< 70	dB(A)
Maximum output speed OPEN / CLOSE for frequency inverter operation	12	min ⁻¹
Cycles per hour	12 (10,2) ¹⁾	h ⁻¹
Max. holding torque	800	Nm
Manual force emergency manual operation	159	N
Explosion protection	II 2G Ex db eb h IIC T4 Gb II 2D Ex tb h IIIC 130°C Db	
Installation height	< 1000	m

Components used	
Gearbox	SG 115 123.T4
Motor	RL 90S4
Terminal box	8146/1041
Limit switch / emergency manual operation switch	07-2511

3 Technical data gearbox

Designation		
Series	SG115-123.T4	
Manufacturer	GfA	
Explosion protection	II 2G Ex h IIC T4 Gb II 2D Ex h IIIC 130°C Db	
Max. output torque	800	Nm
Max. output speed	15	min ⁻¹
Shaft centre distance	115	mm
Transmission ratio	1 : 123	
Temperature range	-20 / +40	°C
Protection class	IP 65	

4 Technische Daten Motor

Bezeichnung		
Typ	RL 90S4	
Hersteller	RAEL MOTORI ELETTRICI S.R.L	
Explosionsschutz	II 2G Exde IIC T4 Gb II 2D Ex tb IIIC T135° Db	
Prüfbescheinigung	CESI 20 ATEX 040 X	
Betriebsspannung	230 / 400	V
Betriebsstrom	4,67 / 2,7	A
Betriebsfrequenz	50	Hz
Leistung	1,1	kW
Leistungsfaktor $\cos \phi$	0,65	
Motordrehzahl	1440	min ⁻¹
Motordrehmoment	7,7	Nm
Betriebsart	S1	
Schutzart	IP66	
Temperaturklasse	T4	
Verhältnis I_A / I_N	4,2	
Bremsmoment Federkraftbremse	10	Nm
Bremsspannung	105	V DC
Betriebsstrom Federkraftbremse	1	A
Gleichrichtertyp	DC	
Temperaturbereich	-20 °C - 40 °C	°C

5 Technical data terminal box

Designation		
Type	Ex e 8146/1041	
Manufacturer	Stahl	
Explosion protection	II 2G Ex e II T6 II 2D Ex tD A21 IP 66 T80°C	
Certificate of verification	PTB 01 ATEX 1016	
Supply voltage	250 max. 1100	V
Terminal cross-section	2,5	mm ²
Temperature range	T6: -20 / +40 T5: -20 / +55	°C
Degree of protection	IP 65	

6 Technical data limit switch / switch emergency manual operation

Designation		
Type	07-2511-113061G	
Manufacturer	Bartec	
Explosion protection	II 2G Ex d IIC T6 II 2D Ex tD A21 IP 66 T80°C	
Certificate of verification	EPS 14 ATEX 1766 X	
Supply voltage	400	V
Temperature range	-20 / +40	°C
Degree of protection	IP 66	

CAUTION

Component damage can result

- The maximum allowable current applied to the limit switches is 2A 400V for AC-15 and 0.15 250V for DC-13.

7 Mechanical installation



Warning – Explosion hazard!

- Check the atmosphere for explosion hazards before commencing installation

Requirements

The permissible loads on walls, mountings, connection and transmission elements must not be exceeded even for maximum holding or locking torque (► observe technical data).

Connection elements

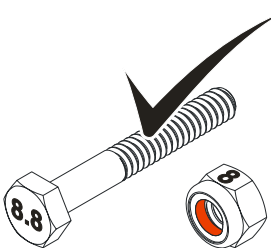
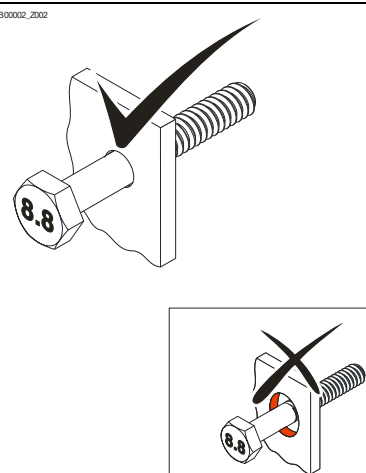
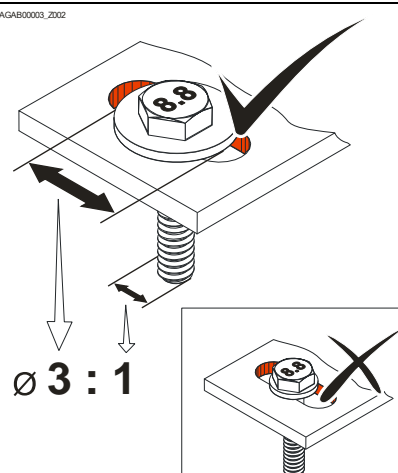
<p>Use self-locking connection elements with a minimum strength of 800 N/mm² (8.8).</p>	<p>Use a screw that precisely fits the hole.</p>	<p>Use adequately dimensioned washers for elongated holes.</p>
<p><small>BAGAB00001_2002</small></p>  <p>≥ 800 N/mm²</p>	<p><small>BAGAB00002_2002</small></p> 	<p><small>BAGAB00003_2002</small></p>  <p>Ø 3 : 1</p>

Permissible mounting positions

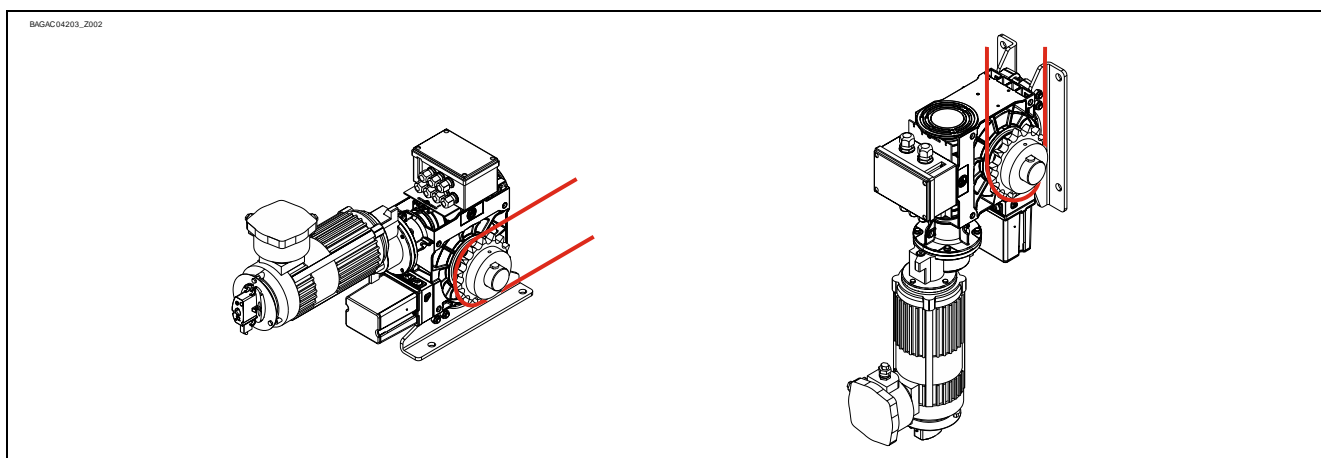

Transmission elements

Correctly fit the sprocket.

BAGAB00021_2001

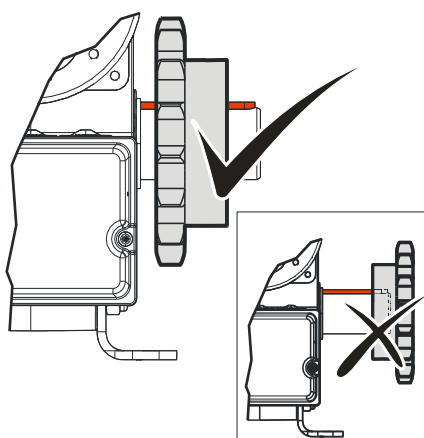

Correctly position the sprockets.

BAGAB00022_2001

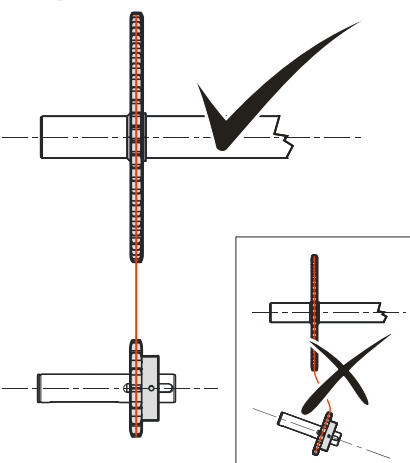

Correctly tension the chain.

BAGAB00023_2001

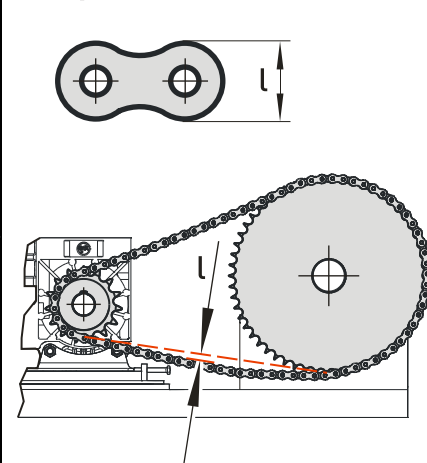

Mounting

4 boreholes are provided for mounting.

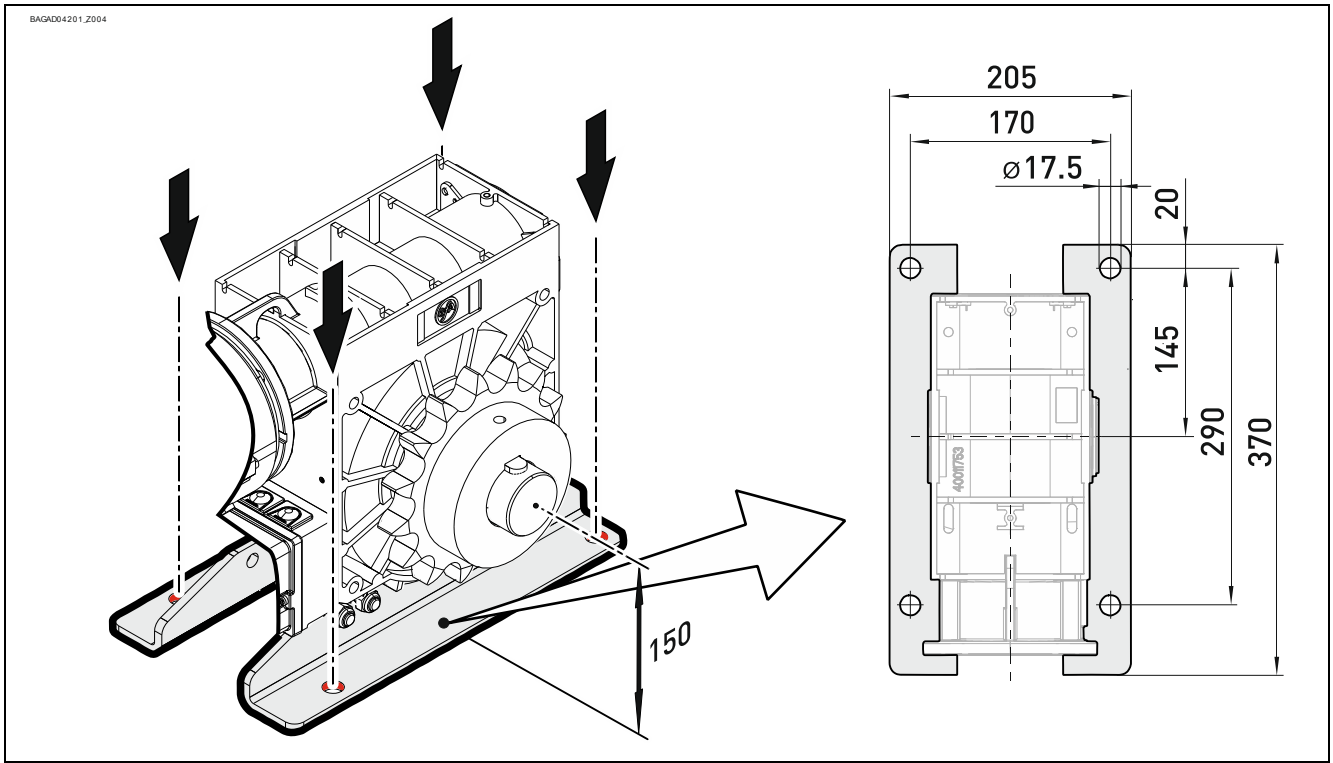

Installation

The following descriptions refer to a door which is not further defined. The door manufacturer's specifications must also be observed.



Warning – Injury or danger to life possible!

- Use a lifting device with sufficient load-carrying capacity for installation tasks.

Completely grease the output shaft.

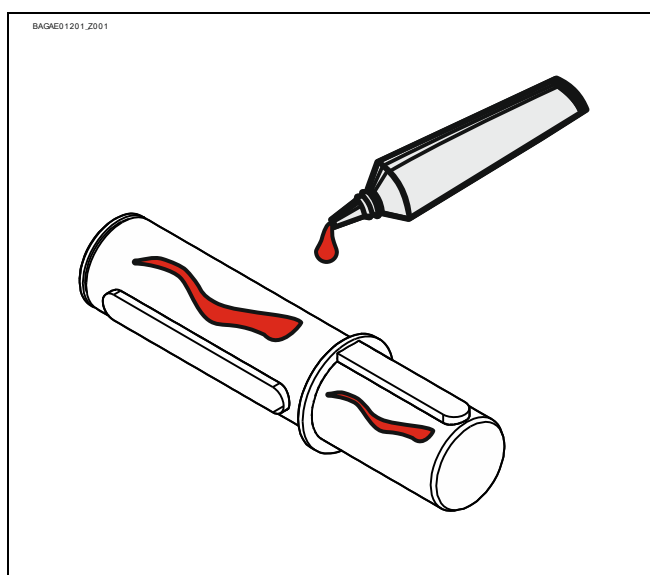

Mount (①) and fixate (②) the sprocket. Do not yet tighten. Mount the output shaft at the right- or left-hand side (③) and fixate it (④).

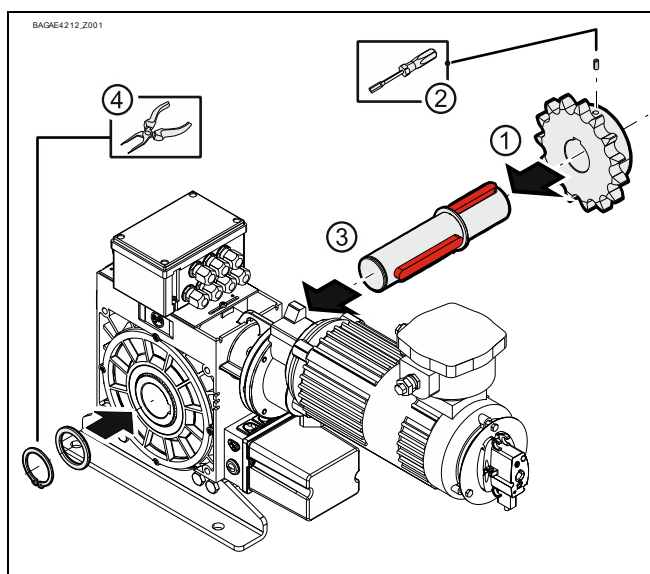

Mount the drive unit. Do not yet tighten.

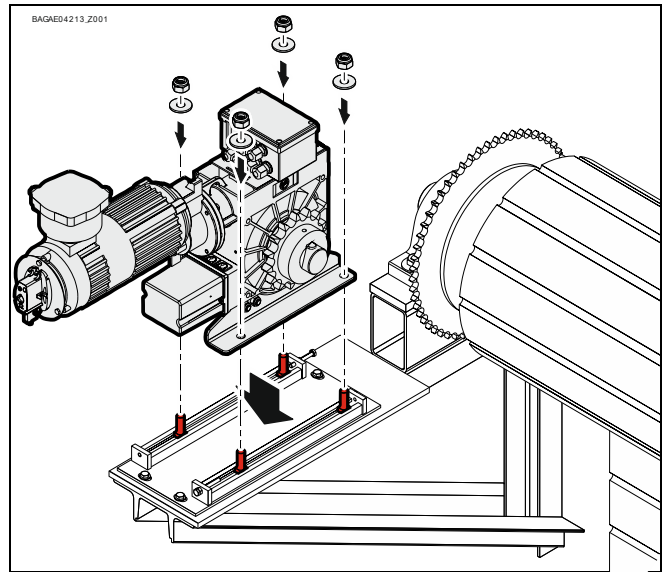

Correctly position the sprocket (①). Mount the chain (②). Fixate the sprocket (③).

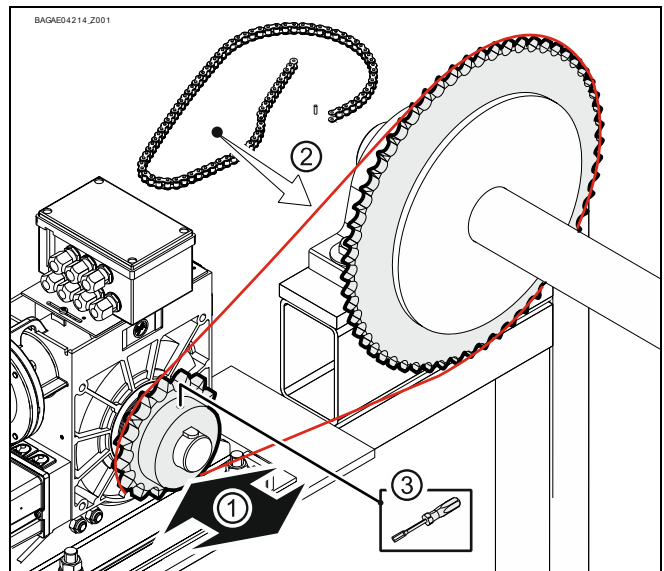

Correctly tension the chain (①/②). Tighten all connection elements (M16) with 175 Nm (③). Install all further connection elements according to the specifications of the door manufacturer.

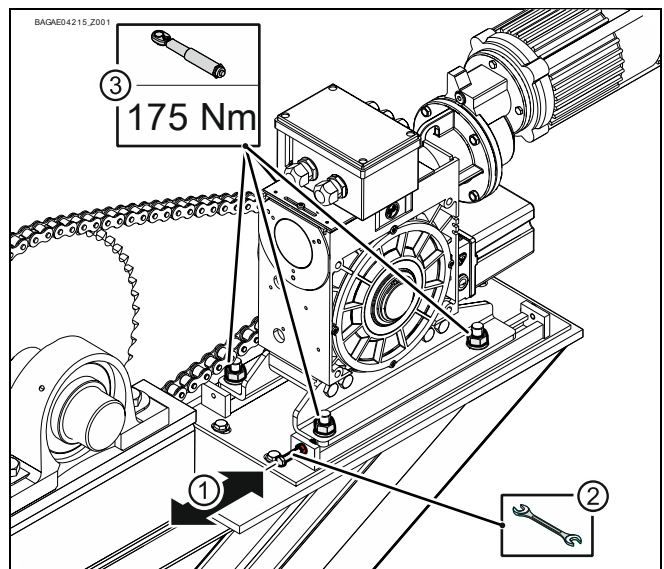

8 Electrical installation



Warning – Danger to life from electrical shock!

- Disconnect the cables (mains OFF) and check that the supply is off
- Observe the applicable regulations and standards
- Ensure proper electrical connection
- Use suitable tools

Carrying out the electrical installation

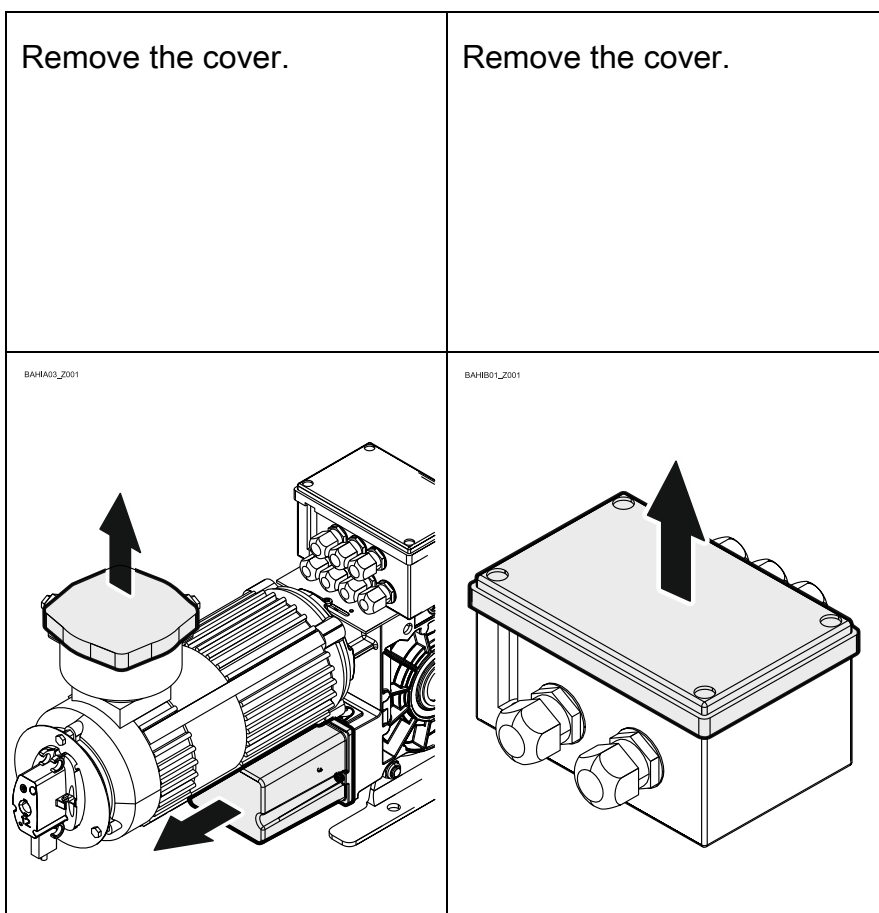

Connect motor/limit switch connection cable

Protection against overload

Motor protection switch / motor protection relay mains operation

The "Ex" motor must be protected against overload by means of a motor protection switch or a motor protection relay. Only use motor protection relays with manual reset. Short-circuit protection is also required. Excess current must be set on the basis of the I_A / I_N ratio.

PTC resistor signal mains operation

The motor is equipped with installed temperature sensors (PTC) which can be used as overload protection. This protection class is approved as the sole protection against overload for flameproof motors "d"; it must be equipped with a separate evaluation unit. The evaluation unit measures the temperature of the motor coil and deactivates the motor as soon as the preset temperature is exceeded. This safety device can only be reset by hand. Short-circuit protection is also required.

PTC resistor signal frequency inverter operation

Evaluation is similar to that in mains operation. The motors have an additional rating plate. The features on the additional rating plate must be checked before initial operation of the motor. The connecting cable of the temperature sensors (PTC) must be routed separately to the motor cable.



Frequency inverter operation!

- Shielded motor cables must be used.
- Shielded cables require separate cable glands.
- The brake requires a separate supply line.

Completing the electrical installation

Install cable entries and/or cable glands.



Flameproof enclosure!

- The motor cable gland must ensure that the flameproof enclosure is closed.

In order to achieve the required tightness, the cable glands are equipped with different sealing inserts. They are available for the following cable diameters:

5.5 – 8.0; 8.0 - 10.5 and 10. – 13 mm.

Sealing insert and cable diameter must be aligned. Cable glands are only suited for lines with a smooth surface.

9 Limit switch setting

The limit switch setting defines the final limit positions OPEN and CLOSE.

Requirement

The door should open by pressing the OPEN push-button of the control. If the door closes, L1 and L2 must be swapped in a de-energised state.

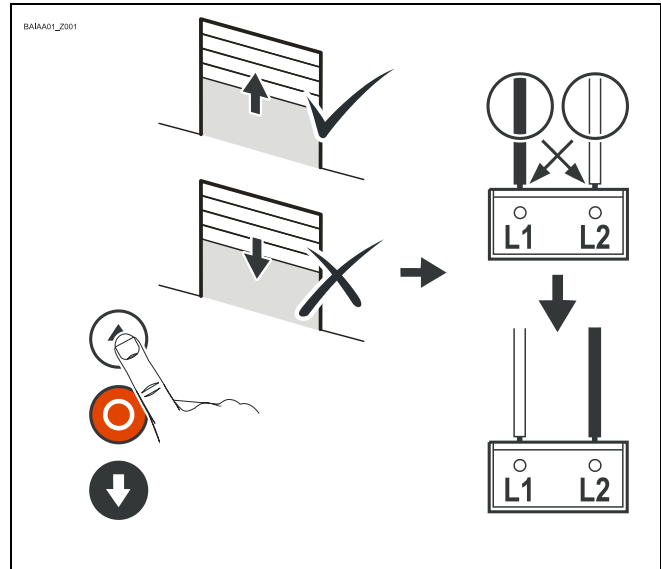

Setting of OPEN final limit position

Open to the desired OPEN final limit position using the OPEN push-button.

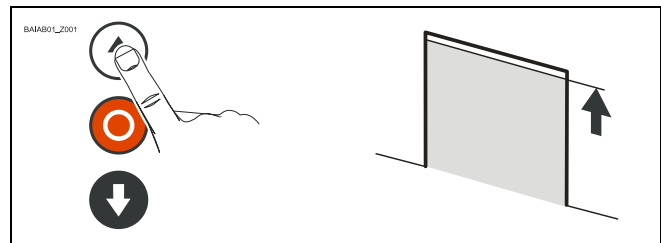

Turn the cam of the S3 OPEN limit switch to the centre of the switch plunger ①.
Tighten the screw of the cam ②.

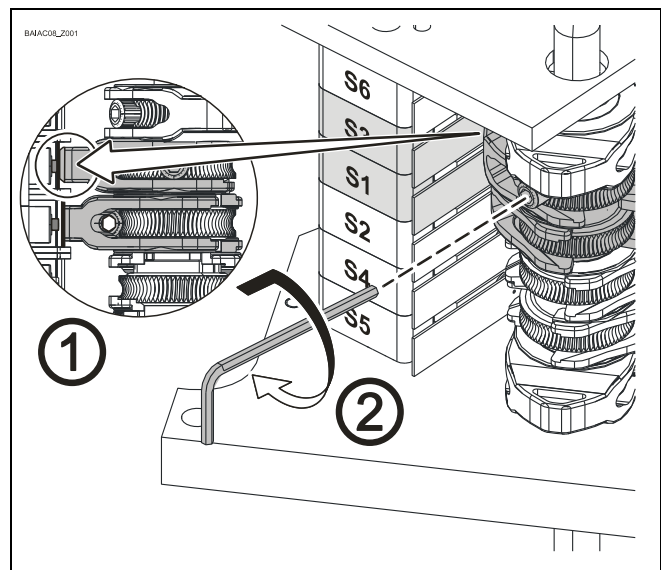

Check the door position:

Close the door ① until the cam is released and open it again ② until the OPEN final limit position is reached.

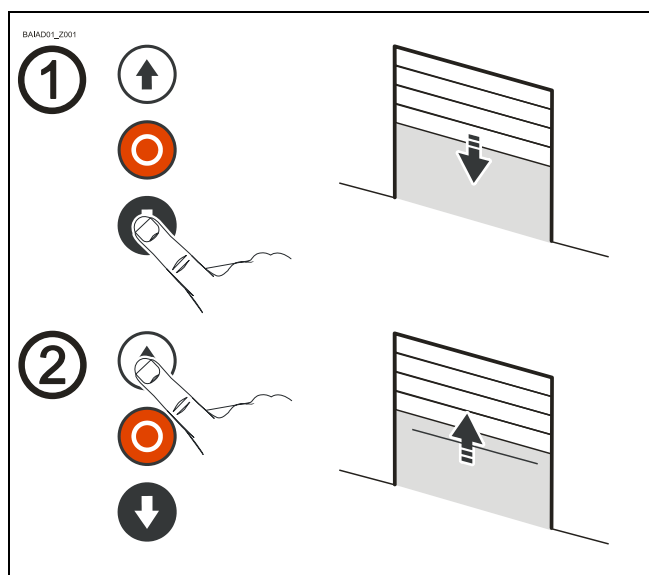

The OPEN final limit position can be corrected by following the fine adjustment procedure. Check the door position after each correction.

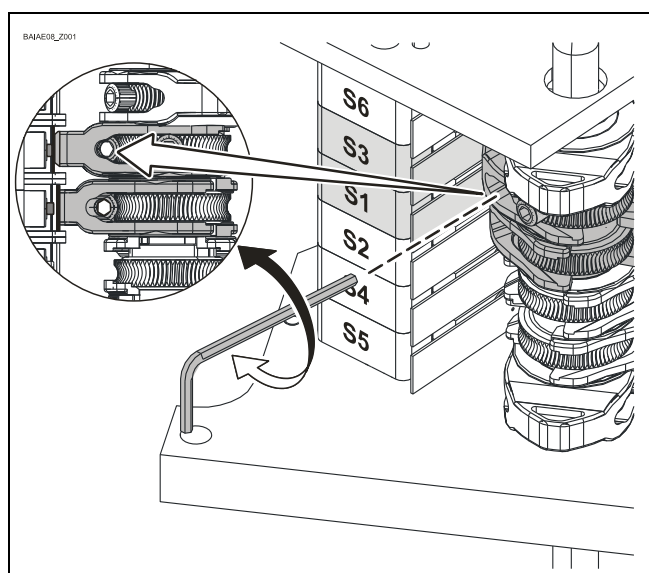

The S1 EMERGENCY OPEN limit switch is preset by the setting of the OPEN final limit position. The door must stop without posing any risks should the rotating direction be incorrect or should there be a fault with the S3 OPEN limit switch. Follow the fine adjustment procedure to correct the switching point of the limit switch as needed.

Setting of CLOSE final limit position and auxiliary limit switch

The same setting procedure applies as for setting the OPEN final limit position.

10 Motor connection

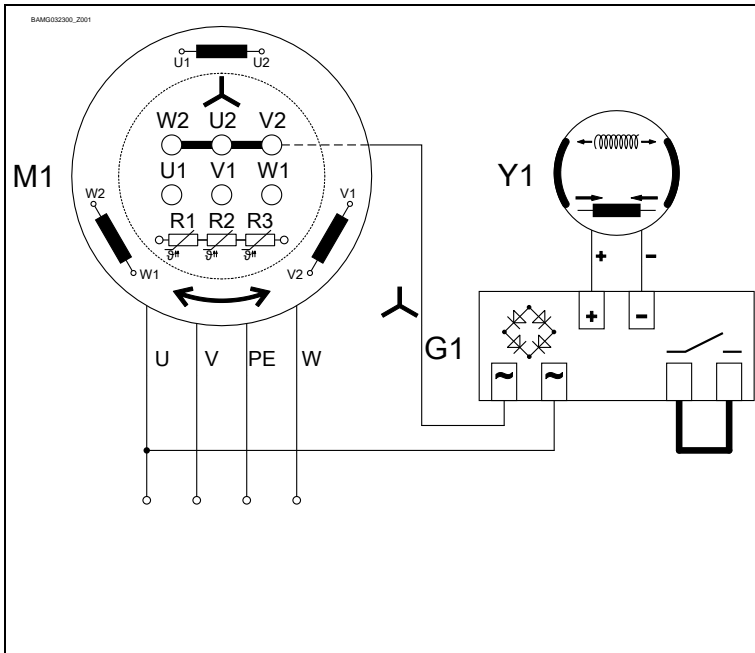

G1	Bridge rectifier DC-side switching
M1	Motor
R1	PTC thermistor
R2	PTC thermistor
R3	PTC thermistor
Y1	Spring applied brake

11 Limit switch connection

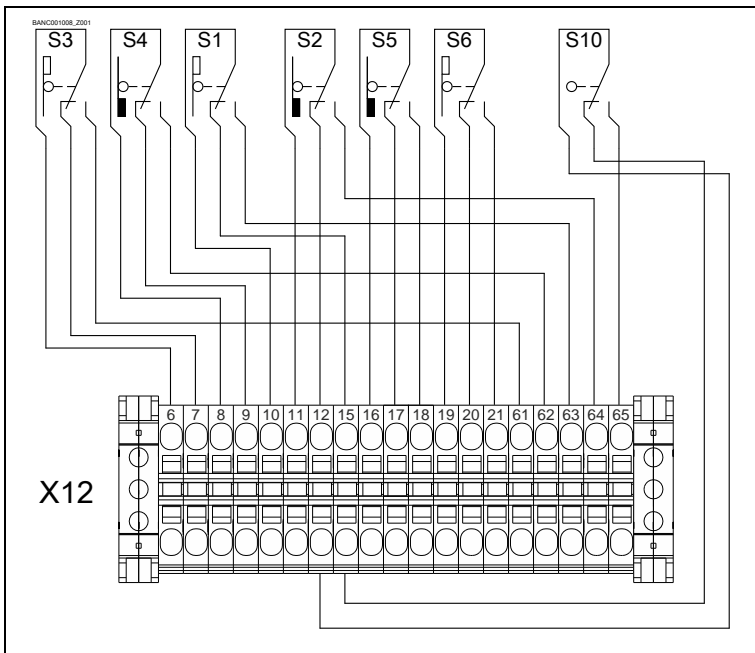

S10	Emergency manual operation
X12	Terminal strip
S1	Emergency OPEN limit switch
S2	Emergency CLOSE limit switch
S3	OPEN limit switch
S4	CLOSE limit switch
S5	Additional limit switch
S6	Additional limit switch

12 Emergency manual operation (emergency hand crank)

The emergency manual operation is designed for opening or closing the door without power supply. Its activation interrupts the control voltage. Electrical operation is no longer possible.



Warning – Injuries due to incorrect operation or falling objects!

- Switch off voltage.
- Adopt a secure position.
- For drive units with brake, the emergency manual operation must be carried out against the closed brake.



Warning - Danger of the door dropping!

If you need to apply more than the permissible force of 390N (according to DIN EN 12604/DIN EN 12453) to move the door by emergency manual operation, this indicates a stalling on the drive unit or door. Releasing the stalling may cause the door to drop.

- Adopt a secure position
- For drive units with brake, the emergency manual operation must be carried out against the closed brake.



Caution – Damage to components!

- Do not move the door beyond the final limit positions.



Warning – Risk of injury due to uncontrolled movements and falling objects!

The drive unit could start up unexpectedly and injure people should a wrong emergency hand crank be used. A wrong crank will drop out of the mounting and injure people.

- Only use a crank with the correct diameter. The diameter is indicated on the crank handle switch:

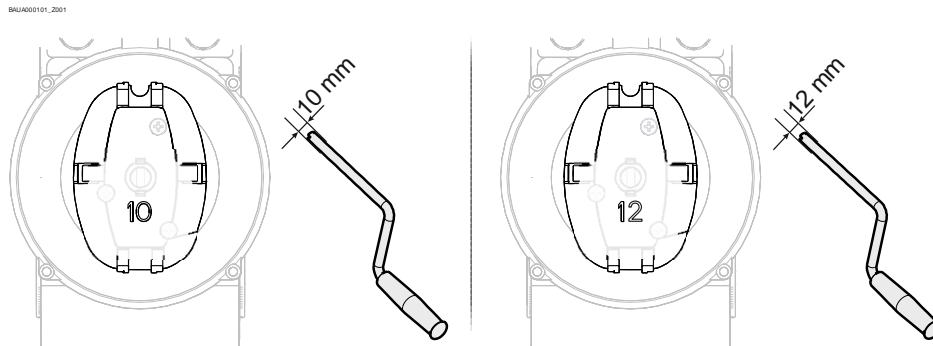

Plug in the crank and turn until it engages (①). Open or close by turning the crank (②).

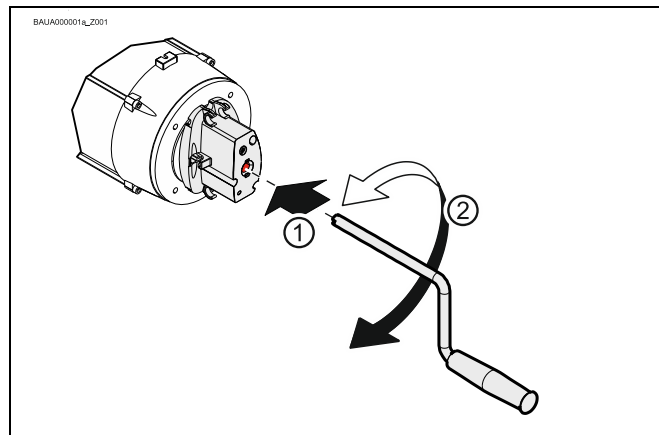

After use, the crank may be attached to the drive unit.
Attach as illustrated.

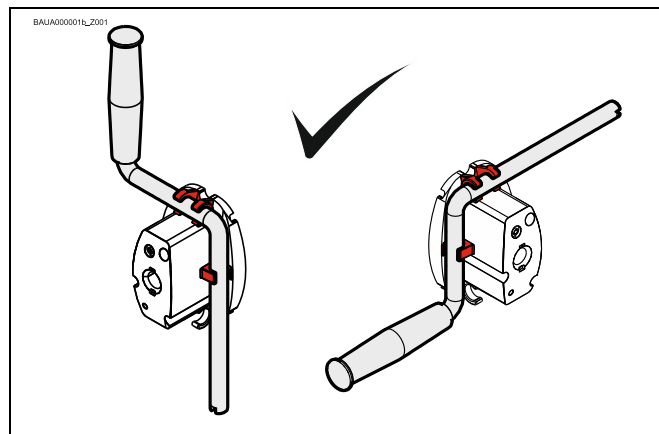

13 Completion of initial operation / inspection / operation

Check the following components and after that, mount all covers.

Gearbox

Check drive unit for oil loss (some drops are not critical). Protect output shaft permanently against corrosion.



Oil loss!

- Oil loss may render explosion protection ineffective. Oil maintenance is inadmissible.

Motor

Check motor for defective bearings

Mounting

Check all mounting elements (consoles, torque mounts, screws, retaining rings etc.) for tightness and impeccable condition.

Electric wiring

Check connection cables and cables for damage or pinches. Check screw connections for correct seating and electrical contact.

Emergency actuation

Function to be checked in a de-energised state. Check for correct functioning is to be carried out between the final limit positions only.

Limit switches

Check the final limit positions by opening and closing the door completely. The safety zone must not be reached.

Brake



Warning – Injury or danger to life possible!

- Carry out brake test. Overrun depends on the door and its equipment. The manufacturer's specifications must be observed.



Warning – Injury or danger to life possible!

Service life of the brake - replacement of the entire brake with motor in the case of:

- Operation with mains supply: after 750,000 door cycles
- Operation with frequency inverter: after 1,500,000 door cycles

Entire drive unit



Attention – Dust deposits!

- Properly remove dust deposits at regular, adequately short intervals, should these be unavoidable due to operation processes. Performed cleaning tasks should be documented.



Note!

- Have a specialist check the drive unit once a year.
- Shorter inspection interval for frequently used doors.
- Observe the applicable regulations and standards

14 Disposal

Dispose of packaging

Dispose of the packaging material properly according to the local legal regulations or recycle it.

Dispose of old devices

Dispose of old devices properly according to local legal regulations. Return old devices to the return and collection systems available. You can also return GfA products free of charge.

Please apply enough postage to the package and mark it as "old devices".



Notice- Environmental damage!

The gearbox contains oil.

- Ensure proper disposal according to local legal regulations.

EU Declaration of conformity

within the meaning of Explosion Protection Directive 2014/34/EU
regarding the safe assembly of components



GfA ELEKTROMATEN GmbH & Co. KG
Wiesenstraße 81 · 40549 Düsseldorf
Germany

We

GfA ELEKTROMATEN GmbH & Co. KG

declare under our sole responsibility that the following modules comply with the above directive and that no new hazards arise from their assembly. The assembled modules are intended only for installation in a door system.

Standards applied:

EN ISO 80079-36:2016

Explosive atmospheres -

Part 36: Non-electrical equipment for explosive atmospheres - Basic method and requirements.

Drive unit

KE 80.12-55,00 Ex

Part no.: 10005490 00001

Consisting of:

Gearbox series: SG 115 123.T4

Motor: RL 90S4

Terminal box: 8146/1041

Limit switches: 07-2511

Higher-level product identification code



II 2G Ex db eb h IIC T4 Gb



II 2D Ex tb h IIIC 130°C Db

Düsseldorf, 10.08.2018

Stephan Kleine

CEO

Signature

EU Declaration of conformity

within the meaning of Explosion Protection Directive 2014/34/EU
Appendix VIII, "Internal production control"





GfA ELEKTROMATEN GmbH & Co. KG
Wiesenstraße 81 · 40549 Düsseldorf
Germany

We,
GfA ELEKTROMATEN GmbH & Co. KG
declare under our sole responsibility that the
following module complies with the above
directive and that no new hazards arise from
assembly. The assembled modul are only
intended for installation in a door system.

Gearbox
SG 115 123.T4

Identification of the product according to
Directive:

 II 2G Ex h IIC T4 Gb

 II 2D Ex h IIIC 130°C Db

Notified body pursuant to Directive:
TÜV Nord Anlagetechnik GmbH
Am TÜV 1
30519 Hannover, Deutschland

Registration number: 8000306986

Düsseldorf, 01.10.2019

Stephan Kleine
CEO



Signature

Standards applied:

EN ISO 80079-36:2016

Explosive atmospheres -

Part 36: Non-electrical equipment for explosive
atmospheres - Basic method and requirements.

EN ISO 80079-37:2016

Explosive atmospheres -

Part 37: Non-electrical equipment for explosive
atmospheres - Non-electrical type of protection
constructional safety "c", control of ignition
sources "b", liquid immersion "k".

RAEL MOTORI ELETTRICI

Via Per Retorto 7/1 - 15077 PREDOSA (AL) - ITALY Tel: +39 (0) 131 71 563 - Fax: +39 (0) 131 71 503

Predosa il 23/05/2023

Dichiarazione UE di Conformità

EU Declaration of Conformity / Declaration UE de Conformite EU Konformitätserklärung / Declaration UE de Conformidad

Rael dichiara sotto la sua sola responsabilità che i motori elettrici asincroni
Electric asynchronous motors / Les moteurs électriques asynchrone
Elektrische asynchronmotoren typ / Los motores electricos asincronos del tipo

SERIE BRAKEX

Serial number: from: to

Che riportano la marcatura
Bearing the marks / Marques / Kennzeichnung / Que llevan marcado

CE 0722 Ex	II 2G Ex db eb IIC T5 Gb II 2D Ex tb IIIC Db T=85°C Ta: -20°C to 40°C IP66 CESI 20 ATEX 040

Sono prodotti da RAEI MOTORI ELETTRICI S.r.l. in accordo alle seguenti Direttive
Have been manufactured by RAEI MOTORI ELETTRICI S.r.l. in accordance with the Directives
Sont fabriqués par la société RAEI MOTORI ELETTRICI S.r.l. selon les Directives suivantes
Wurden gefertigt von RAEI MOTORI ELETTRICI S.r.l. in Übereinstimmung mit den folgenden -Richtlinien
Han sido fabricados por RAEI MOTORI ELETTRICI S.r.l. de acuerdo con las siguientes Directivas

2014/34/EU - 2015/863/EU

e in conformità alla seguente Norma
and comply with the following Standards / et enconformité avec les Normes
und entsprechen den folgenden Standard / y conform a las siguientes Normas

EN 60079-0:2018 | EN 60079-1:2014 | EN 60079-7:2015+ A1 2018 | EN 60079-31:2014 | EN 60034-1:2010 | EN 60034-5: 2001 | EN 60034-6:1993
EN 60034-7:1993 | EN60034-8:2007 | 60034-9:2005 | EN 60034-14:2004 | IEC60072-1:1991

Il produttore dichiara la conformità alla norma EN 60079-0 2018 e alla norma EN 60079-7 2015 + A1 2018 anche se il prodotto è stato certificato secondo le norme EN 60079-0 2012+A11 2013 e 60079-7 2015. The manufacturer declares the conformity with EN 60079-0 2018 and the standar EN 60079-7 2015 + A1 2018 even if the product is certified according to EN 60079-0 2012+A11 2013 and EN 60079-7 2015 Le fabricant déclare la conformité à la norme EN 60079-0 2018 et la norme EN 60079-7 2015 + A1 2018 , même si le produit est certifié selon la norme EN 60079-0 2012+A11 2013 et EN 60079-7 2015 Der Hersteller erklärt die Konformität mit EN 60079-0 2018 und EN 60079-7 2015 + A1 2018 selbst wenn das Produkt zertifiziert nach EN 60079-0 2012+A11 2013 und 60079-7 2015 El fabricante declara la conformidad con la norma EN 60079-0 2018 en la norma EN 60079-7 2015 + A1 2018 incluso si el producto está certificado según la norma EN 60079-0 2012+A11 2013 y EN 60079-7 2015

NOTA/ NOTE/ BEMERKUNG/ NOTAS:

Direttiva Macchine, Machinery Directive, Directive Machine, Maschinen-Richtlinie, Directiva Maquinaria

I motori in oggetto sono considerati componenti, in accordo con la direttiva macchine. Il motore non deve essere messo in servizio finché la macchina stessa su cui è montato non venga dichiarata conforme alla direttiva macchine.

Above motors considered as components, comply with the directive machine. The motor must not be incorporated in service until the machine itself has not been declared in conformity with the machinery directive.

Les moteurs ci-dessus considérés comme composants sont conformes à la directive machine. Le moteur ne peut être incorporé et mis en service avant que la machine dans laquelle il est incorporé ne soit déclarée conforme à la directive machine.

Für die korrekte installation der oben genannten Motore sowie der entsprechenden komponenten, die in ihrer Bauart mit den zu dieser Bescheinigung aufgeführten Vorshriften übereinstimmen, ist der Mashinenhersteller/Maschinenbetreiber verantwortlich. Die Motoren entsprechen den Vorshriften nur, solange die Anlage, in der sie eingebaut wurden, in übereinstimmung mit den geltenden Maschinen-richtlinien und Vorshriften errichtet wurde.

Los motores en objecto, por tratarse de componentes, cumplen las normas de la directiva si la instalacion está correctamente controlada por el constructor de la máquina. El motor no debe entrar en servicio hasta que la máquina en que ha sido incorporado disponga de la declaration de la directiva maquinaria

Product Quality Assurance Notification Number: CESI 03-ATEX-038Q
EU Type examination issued by CESI - Via Rubattino 54 - 20134 Milano Italy
Notified by CESI - Notified Body n.0722 - Via Rubattino 54 - 20134 Milano Italy

EU Konformitätserklärung
EU Declaration of Conformity
Déclaration de Conformité UE



R. STAHL Schaltgeräte GmbH • Am Bahnhof 30 • 74638 Waldenburg, Germany
 erklärt in alleiniger Verantwortung, *declares in its sole responsibility, déclare sous sa seule responsabilité,*

dass das Produkt: <i>that the product:</i> <i>que le produit:</i>	Klemmenkästen <i>Terminal Boxes</i> <i>Boîtes de jonction</i>
Typ(en), type(s), type(s):	8146/1 8146/2

mit den Anforderungen der folgenden Richtlinien und Normen übereinstimmt.
is in conformity with the requirements of the following directives and standards.
est conforme aux exigences des directives et des normes suivantes.

Richtlinie(n) / Directive(s) / Directive(s)		Norm(en) / Standard(s) / Norme(s)
2014/34/EU	ATEX-Richtlinie	EN IEC 60079-0:2018
2014/34/EU	<i>ATEX Directive</i>	EN 60079-1:2014
2014/34/UE	<i>Directive ATEX</i>	EN IEC 60079-7:2015 + A1:2018
		EN 60079-11:2012
		EN 60079-18:2015 + A1:2017 + AC:2018
		EN 60079-28:2015
		EN 60079-31:2014

Kennzeichnung, marking, marquage:

II 2 G Ex db eb ia mb op pr IIC T6...T4 Gb II 2 G Ex ia IIC T6...T4 Gb II 2 D Ex tb IIIC T80 °C...T130 °C Db	
--	--

EU Baumusterprüfbescheinigung:
EU Type Examination Certificate:
Attestation d'examen UE de type:

PTB 01 ATEX 1016
 (Physikalisch-Technische Bundesanstalt,
 Bundesallee 100, 38116 Braunschweig, Germany, NB0102)

Produktnormen nach Niederspannungsrichtlinie:
Product standards according to Low Voltage Directive:
Normes des produit pour la Directive Basse Tension:

EN 61439-1:2011
 EN 61439-2:2011

2014/30/EU	EMV-Richtlinie	Nicht zutreffend nach Artikel 2, Absatz (2) d).
2014/30/EU	<i>EMC Directive</i>	<i>Not applicable according to article 2, paragraph (2) d).</i>
2014/30/UE	<i>Directive CEM</i>	<i>Non applicable selon l'article 2, paragraphe (2) d).</i>

2011/65/EU	RoHS-Richtlinie	EN IEC 63000:2018
2011/65/EU	<i>RoHS Directive</i>	
2011/65/UE	<i>Directive RoHS</i>	

Waldenburg, 2021-03-01

Ort und Datum
Place and date
Lieu et date

i.V.

Holger Semrau
Leiter Entwicklung Schaltgeräte
Director R&D Switchgear
Directeur R&D Appareillage

i.V.

Jürgen Freimüller
Leiter Qualitätsmanagement
Director Quality Management
Directeur Assurance de Qualité

EU Konformitätserklärung
 EU Declaration of Conformity
 Déclaration UE de conformité
 N° 01-2511-7C0001_B

BARTEC

Wir	We	Nous
BARTEC GmbH Max-Eyth-Straße 16 97980 Bad Mergentheim Germany		
erklären in alleiniger Verantwortung, dass das Produkt Endschalter Positionsschalter	declare under our sole responsibility that the product Limit Switch Position switch	attestons sous notre seule responsabilité que le produit Fin de course Interrupteur de position

Limit Switch Typ: 07-2511-**/****; 07-2581-****/****;**
Position Switch Typ: 07-291*-**/******

auf das sich diese Erklärung bezieht den Anforderungen der folgen- den Richtlinien (RL) entspricht ATEX-Richtlinie 2014/34/EU RoHS-Richtlinie 2011/65/EU RoHS-Richtlinie 2015/863/EU und mit folgenden Normen oder nor- mativen Dokumenten übereinstimmt	to which this declaration relates is in accordance with the provision of the following directives (D) ATEX-Directive 2014/34/EU RoHS-Directive 2011/65/EU RoHS-Directive 2015/863/EU and is in conformity with the following standards or other normative documents	se référant à cette attestation correspond aux dispositions des direc- tives (D) suivantes Directive ATEX 2014/34/UE Directive RoHS 2011/65/UE Directive RoHS 2015/863/UE et est conforme aux normes ou docu- ments normatifs ci-dessous
---	--	--

EN IEC 60079-0:2018
EN 60079-1:2014
EN 60079-31:2014
EN 60529:1991
+ A1:2000 + A2:2013
EN 60947-1:2007 +
A1:2011 + A2:2014
EN 60947-5-1:2017

Verfahren der EU-Baumuster- prüfung / Benannte Stelle	Procedure of EU-Type Examination / Notified Body	Procédure d'examen UE de type / Organisme Notifié
--	---	--

EPS 14 ATEX 1766 X, Issue 1

2004, Bureau Veritas CPS Germany GmbH, Businesspark A96, 86842 Türkheim_

CE 0044

Bad Mergentheim, 17.02.2020

 i.A. Simon Dyhringer
 Product Manager Ex e

 i.V. Cristian Olareanu
 Team Leader Certification Center

Declaration of incorporation

within the meaning of Machinery Directive 2006/42/EC
for partly completed machinery, Appendix II Part B



GfA ELEKTROMATEN GmbH & Co. KG
Wiesenstraße 81 · 40549 Düsseldorf
Germany

Declaration of conformity

within the meaning of EMC Directive 2014/30/EU
within the meaning of RoHS Directive 2011/65/EU

We,
GfA ELEKTROMATEN GmbH & Co. KG
declare under our sole responsibility that the
following product complies with the above
directives and is only intended for installation in a
door system.

Drive unit

KE 80.12-55,00 Ex

Part no.: 10005490 00001

We undertake to transmit in response to a
reasoned request by the appropriate regulatory
authorities the special documents on the partly
completed machinery.

This product must only be put into operation
when it has been determined that the complete
machine/system in which it has been installed
complies with the provisions of the above-
mentioned directives.

Authorised representative to compile the
technical documents is the undersigned.

Düsseldorf, 10.08.2018

Stephan Kleine
CEO

Signature

The following requirements from Appendix I of
the Machinery Directive 2006/42/EC are met:

1.1.2, 1.1.3, 1.1.5, 1.2.2, 1.2.3, 1.2.6, 1.3.2,
1.3.3, 1.3.9, 1.5.1, 1.5.2, 1.5.4, 1.5.6, 1.5.7,
1.5.8, 1.5.9, 1.5.10, 1.5.11, 1.5.13, 1.6.1, 1.6.2,
1.6.4, 1.7.2, 1.7.3, 1.7.4.3.

Standards applied:

EN 12453:2017+A1:2021

Industrial, commercial and garage doors and
gates - Safety in use of power operated doors -
Requirements

EN 12604:2017

Industrial, commercial and garage doors and
gates - Mechanical aspects - Requirements

EN 60335-1:2012

Household and similar electrical appliances -
Safety - Part 1: General requirements

EN 61000-6-2:2005

Electromagnetic compatibility (EMC) Part 6-2
Generic standards – Immunity standard for
industrial environments

EN 61000-6-3:2007

Electromagnetic compatibility (EMC) Part 6-3
Generic standards – Emission standard for
residential, commercial and light-industrial
environments

Declaration of incorporation

within the meaning of Supply of Machinery (Safety) Regulations 2008
for partly completed machinery, Appendix II Part B



Declaration of conformity

within the meaning of Electromagnetic Compatibility Regulations 2016
within the meaning of Restriction of the Use of Certain Hazardous Substances in
Electrical and Electronic Equipment Regulations 2012



We,

GfA ELEKTROMATEN GmbH & Co. KG

declare under our sole responsibility that the
following product complies with the above
directives and is only intended for installation in a
door system.

Drive unit

KE 80.12-55,00 Ex

Part no.: 10005490 00001

We undertake to transmit in response to a
reasoned request by the appropriate regulatory
authorities the special documents on the partly
completed machinery.

This product must only be put into operation
when it has been determined that the complete
machine/system in which it has been installed
complies with the provisions of the above-
mentioned directives.

Authorised representative:

Andrew Collett

GfA ELEKTROMATEN UK Ltd

Tournament Fields Business Park,

Agincourt Rd,

Warwick CV34 6XZ

Düsseldorf, 01.11.2022

Stephan Kleine

CEO

Signature

The following requirements from Appendix I of
the Supply Machinery (Safety) Regulations 2008
are met:

1.1.2, 1.1.3, 1.1.5, 1.2.2, 1.2.3, 1.2.6, 1.3.2,
1.3.3, 1.3.9, 1.5.1, 1.5.2, 1.5.4, 1.5.6, 1.5.7,
1.5.8, 1.5.9, 1.5.10, 1.5.11, 1.5.13, 1.6.1, 1.6.2,
1.6.4, 1.7.2, 1.7.3, 1.7.4.3.

Applied Standards:

BS EN 12453:2017+A1:2021

Industrial, commercial and garage doors and
gates - Safety in use of power operated doors -
Requirements

BS EN 60335-2-103:2015

Household and similar electrical appliances -
Safety - Part 2-103: Particular requirements for
drives for gates, doors and windows

BS EN 61000-6-2:2005

Electromagnetic compatibility (EMC) Part 6-2
Generic standards – Immunity standard for
industrial environments

BS EN 61000-6-3:2007

Electromagnetic compatibility (EMC) Part 6-3
Generic standards – Emission standard for
residential, commercial and light-industrial
environments