

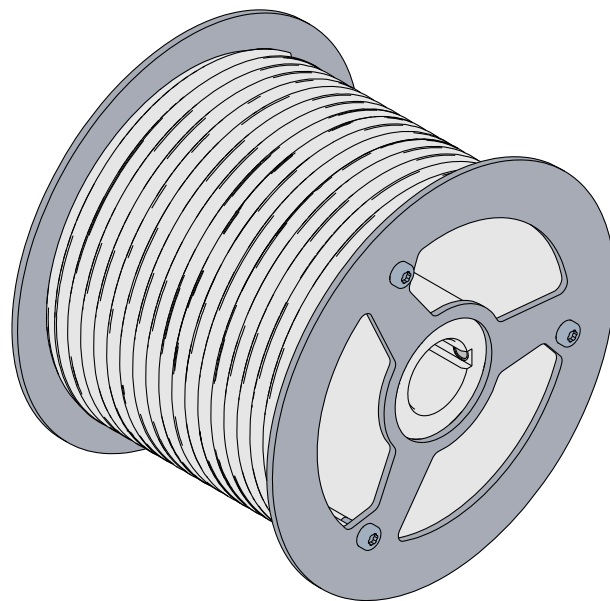

Installation Instructions

Cable drum - Type B

Version: 51171755_00002



-en-

As of: b 07/2022

1 Safety-relevant chapter

Explanation of symbols

The following symbols are used in these installation instructions:

⚠ DANGER

Safety note: Non-compliance will result in death or severe injury.

⚠ WARNING

Safety note: Non-compliance can result in death or severe injury.

⚠ CAUTION

Safety note: Non-compliance can result in injury.

NOTICE

Note: Non-compliance can result in material damage and impairment of product functionality.

i NOTE

Note: Points out useful additional information.

Target audience of the installation instructions

These installation instructions are intended for competent personnel trained in handling doors. Competent personnel qualify by specialist knowledge, skills and practical experience. They can safely carry out installation, maintenance and modernisation according to instructions.

Specified use

The cable drums are intended for the installation on the door shaft. The values given in the technical data must not be exceeded. The safe operation is only guaranteed when the device is used as specified.

GfA ELEKTROMATEN GmbH & Co. KG
Wiesenstraße 81
D-40549 Düsseldorf
www.gfa-elektromaten.de
info@gfa-elektromaten.de

2 Technical data

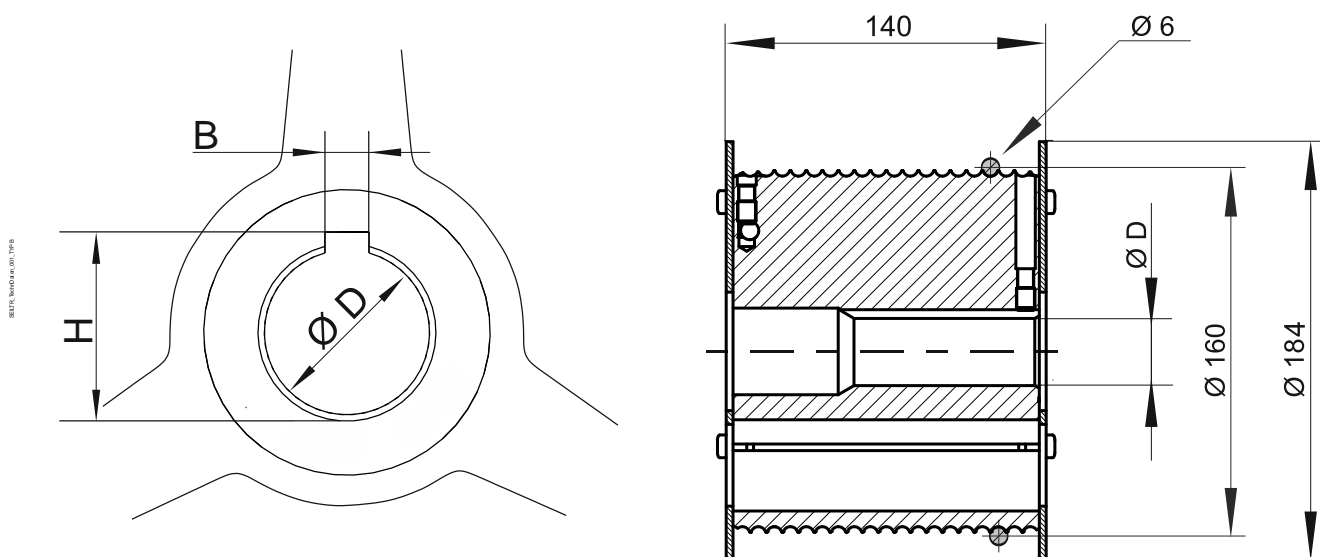

Part no.	Gradient	Ø D	B	H	Usable rope length	Maximum door weight ¹⁾	Permissible force ¹⁾
30005980	right	25 mm	8 mm	28.3 mm	7 m	600 kg	6000 N
30005981	left						
30005982	right	25.4 mm	6.35 mm	28.4 mm			
30005983	left						
30005984	right	30 mm	8 mm	33.3 mm		800 kg	8000 N
30005985	left						
30005986	right	31.75 mm	6.35 mm	34.8 mm			
30005987	left						
30005988	right	40 mm	12 mm	43.3 mm			
30005989	left						

1) When using two cable drums. Use ropes according to EN 12385-4. Design the rope with 6 times the safety factor of the maximum static load acting on the rope. Also, design the rope with 3 times the safety factor to the maximum acting force in the case of catching. The larger of the two values applies.

I NOTE

The gradient and rope diameter are marked on each cable drum.

- For example, R6 = right-hand gradient, rope diameter 6 mm.

3 Installation

▲ WARNING

Risk of death or injury from the uncontrolled movement of the door!

- Use the specified rope diameter.
- Configure the rope with sixfold safety compared to the maximum permissible rope force.
- At least two windings of the rope must remain on the cable drum when the door has reached the final limit position CLOSE.

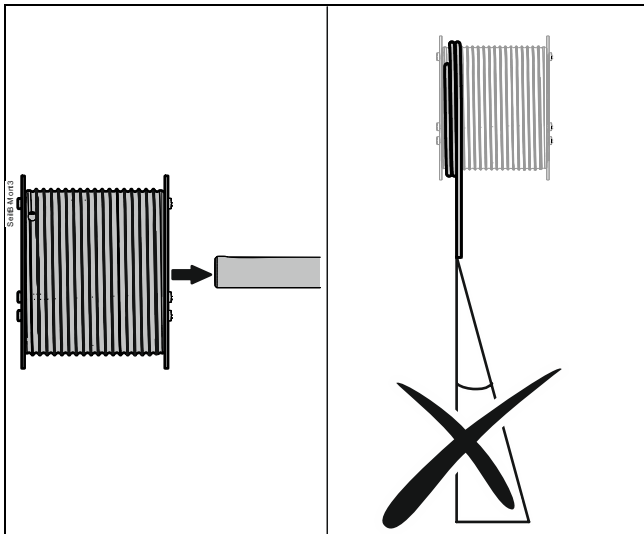

The figure shows a cable drum with a right-hand gradient.

- Put the cable drum on the door shaft.

NOTICE

Failure caused by the rope skipping!

When the rope deflection is too large, the rope may skip. The cable drum or the rope wears out prematurely.

- Keep the rope deflection to a minimum.

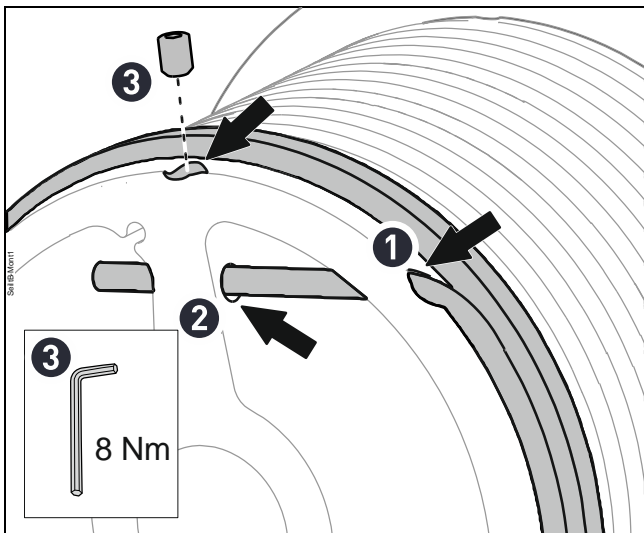

- Thread the rope into the marked holes (1 and 2).
- Secure the rope with the supplied M8 grub screw to a torque of 8 Nm (3).
- Wind two safety windings onto the cable drum.

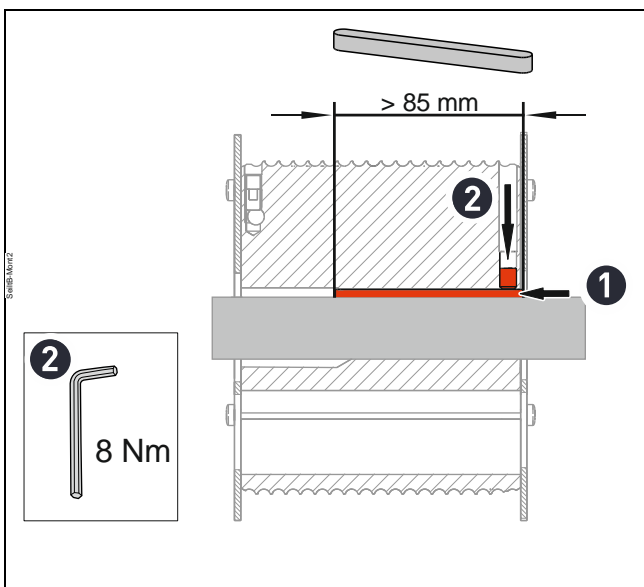

- Insert a key into the groove (1).

⚠ WARNING

Risk of death or injury from the door dropping!

When inserting a key that is too short, the connection between the cable drum and the door shaft will be damaged. The cable drum no longer holds on the door shaft. The door drops.

- Use the full length of the cable drum's groove.

- Secure the cable drum to the door shaft with the supplied M8 grub screw to a torque of 8 Nm (2).
- Proceed in the same way for the second cable drum.